

Agilent E4980A Precision LCR Meter

User's Guide

Ninth Edition

FIRMWARE REVISIONS

This manual applies directly to instruments that have the firmware revision A.02.11.

For additional information about firmware revisions, see Appendix A.



Agilent Technologies

Manufacturing No. E4980-90080

December 2012

Notices

The information contained in this document is subject to change without notice.

This document contains proprietary information that is protected by copyright. All rights are reserved. No part of this document may be photocopied, reproduced, or translated to another language without the prior written consent of Agilent Technologies.

Microsoft®, MS-DOS®, Windows®, Visual C++®, Visual Basic®, VBA®, and Excel® are registered trademarks

UNIX is a registered trademark in the U.S. and other countries, licensed exclusively through X/Open Company Limited.

Portions ©Copyright 1996, Microsoft Corporation. All rights reserved.

© Copyright 2006, 2008, 2010,2012 Agilent Technologies

Manual Printing History

The manual's printing date and manufacturing number indicate its current edition. The printing date changes when a new edition is printed (minor corrections and updates that are incorporated at reprint do not cause the date to change). The manufacturing number changes when extensive technical changes are incorporated.

March 2006	First Edition (manufacturing number: E4980-90000)
July 2006	Second Edition (manufacturing number: E4980-90010)
November 2006	Third Edition (manufacturing number: E4980-90020)
May 2007	Fourth Edition (manufacturing number: E4980-90030)
July 2007	Fifth Edition (manufacturing number: E4980-90050)
October 2007	Sixth Edition (manufacturing number: E4980-90060)
June 2008	Seventh Edition (manufacturing number: E4980-90070)
June 2010	Eighth Edition (manufacturing number: E4980-90080)
June 2012	Nineth Edition (manufacturing number: E4980-90080)

The latest manuals can be downloaded from the following site.

<http://www.agilent.com/find/e4980a/>

Safety Summary

The following general safety precautions must be observed during all phases of operation, service, and repair of this instrument. Failure to comply with these precautions or with specific WARNINGS elsewhere in this manual may impair the protection provided by the equipment. Such noncompliance would also violate safety standards of design, manufacture, and intended use of the instrument. Agilent Technologies assumes no liability for the customer's failure to comply with these precautions.

NOTE

The E4980A complies with INSTALLATION CATEGORY II as well as POLLUTION DEGREE 2 in IEC61010-1. The E4980A is an INDOOR USE product.

NOTE

The LEDs in the E4980A are Class 1 in accordance with IEC60825-1, CLASS 1 LED PRODUCT

- Ground the Instrument

To avoid electric shock, the instrument chassis and cabinet must be grounded with the supplied 3-pole power cable's grounding prong.

- DO NOT Operate in an Explosive Atmosphere

Do not operate the instrument in the presence of inflammable gasses or fumes. Operation of any electrical instrument in such an environment clearly constitutes a safety hazard.

- Keep Away from Live Circuits

Operators must not remove instrument covers. Component replacement and internal adjustments must be made by qualified maintenance personnel only. Do not replace components with the power cable connected. Under certain conditions, dangerous voltage levels may remain even after the power cable has been disconnected. To avoid injuries, always disconnect the power and discharge circuits before touching them.

- DO NOT Service or Adjust the Instrument Alone

Do not attempt internal service or adjustment unless another person, capable of rendering first aid and resuscitation, is present.

- DO NOT Substitute Parts or Modify the Instrument

To avoid the danger of introducing additional hazards, do not install substitute parts or perform unauthorized modifications to the instrument. Return the instrument to an Agilent Technologies Sales and Service Office for service and repair to ensure that safety features are maintained in operational condition.

- Dangerous Procedure Warnings

Warnings in this manual, such as the example below, precede potentially dangerous procedures. Instructions contained in the warnings must be followed.

WARNING

Dangerous voltage levels, capable of causing death, are present in this instrument. Use extreme caution when handling, testing, and adjusting this instrument.

Safety Symbols

General definitions of safety symbols used on the instrument or in manuals are listed below.



Instruction Manual symbol: the product is marked with this symbol when it is necessary for the user to refer to the instrument manual.



Alternating current.



Direct current.



On (Supply).



Off (Supply).



In-position of push-button switch.



Out-position of push-button switch.



A chassis terminal; a connection to the instrument's chassis, which includes all exposed metal structure.



Stand-by.

WARNING

This warning sign denotes a hazard. It calls attention to a procedure, practice, or condition that, if not correctly performed or adhered to, could result in injury or death to personnel.

CAUTION

This Caution sign denotes a hazard. It calls attention to a procedure, practice, or condition that, if not correctly performed or adhered to, could result in damage to or destruction of part or all of the instrument.

NOTE

This Note sign denotes important information. It calls attention to a procedure, practice, or condition that is essential for the user to understand.

Certification

Agilent Technologies certifies that this product met its published specifications at the time of shipment from the factory. Agilent Technologies further certifies that its calibration measurements are traceable to the United States National Institute of Standards and Technology, to the extent allowed by the Institution's calibration facility or by the calibration facilities of other International Standards Organization members.

Warranty

This Agilent Technologies instrument product is warranted against defects in material and workmanship for a period corresponding to the individual warranty periods of its component products. Instruments are warranted for a period of one year. During the warranty period, Agilent Technologies will, at its option, either repair or replace products that prove to be defective.

For warranty service or repair, this product must be returned to a service facility designated by Agilent Technologies. The buyer shall prepay shipping charges to Agilent Technologies, and Agilent Technologies shall pay shipping charges to return the product to the Buyer. However, the Buyer shall pay all shipping charges, duties, and taxes for products returned to Agilent Technologies from another country.

Agilent Technologies warrants that its software and firmware designated by Agilent Technologies for use with an instrument will execute its programming instruction when properly installed on that instrument. Agilent Technologies does not warrant that the operation of the instrument, or software, or firmware, will be uninterrupted or error free.

Limitation of Warranty

The foregoing warranty shall not apply to defects resulting from improper or inadequate maintenance by the Buyer, Buyer-supplied software or interfacing, unauthorized modification or misuse, operation outside the environmental specifications for the product, or improper site preparation or maintenance.

IMPORTANT

No other warranty is expressed or implied. Agilent Technologies specifically disclaims the implied warranties of merchantability and fitness for a particular purpose.

Exclusive Remedies

The remedies provided herein are the Buyer's sole and exclusive remedies. Agilent Technologies shall not be liable for any direct, indirect, special, incidental, or consequential damages, whether based on contract, tort, or any other legal theory.

Assistance

Product maintenance agreements and other customer assistance agreements are available for Agilent Technologies products.

For any assistance, contact your nearest Agilent Technologies Sales and Service Office. Addresses are provided at the back of this manual.

Typeface Conventions

Sample (bold)	Boldface type is used for emphasis.
<i>Sample (Italic)</i>	Italic type is used for emphasis and manual title.
[Sample] key	Indicates a hardkey (key on the front panel or external keyboard) labeled “Sample.” “key” may be omitted.
Sample menu/button/box	Indicates a menu/button/box on the screen labeled “Sample” that can be selected/executed by clicking “menu,” “button,” or “box,” may be omitted.
Sample 1 - Sample 2 - Sample 3	Indicates a sequential operation of Sample 1 , Sample 2 , and Sample 3 (menu, button, or box). “-” may be omitted.

Documentation Map

The following manuals are available for the Agilent E4980A.

- ***User’s Guide (Manufacturing Number E4980-900x0, attached to Option ABA, English)***

This manual describes most of the basic information on the E4980A. It provides a detailed operation procedure for each function (from the function overview to system settings), measurement examples, options, accessories, specifications, GPIB commands, function lists by softkeys, and error messages.

NOTE

The number position shown by “x” in the manufacturing number above indicates the edition number.

Sample Programs

The customer shall have the personal, nontransferable rights to use, copy, or modify SAMPLE PROGRAMS in this manual for the Customer's internal operations. The customer shall use the SAMPLE PROGRAMS solely and exclusively for their own purpose and shall not license, lease, market, or distribute the SAMPLE PROGRAMS or modifications of any part thereof.

Agilent Technologies shall not be liable for the quality, performance, or behavior of the SAMPLE PROGRAMS. Agilent Technologies especially disclaims that the operation of the SAMPLE PROGRAMS shall be uninterrupted or error free. The SAMPLE PROGRAMS are provided AS IS.

AGILENT TECHNOLOGIES DISCLAIMS IMPLIED WARRANTIES OF MERCHANTABILITY AND FITNESS FOR A PARTICULAR PURPOSE.

Agilent Technologies shall not be liable for any infringement of any patent, trademark, copyright, or other proprietary rights by the SAMPLE PROGRAMS or their use. Agilent Technologies does not warrant that the SAMPLE PROGRAMS are free from infringements of such rights of third parties. However, Agilent Technologies will not knowingly infringe or deliver software that infringes the patent, trademark, copyright, or other proprietary right of a third party.

1. Unpacking and Preparation

Checking the Shipment	23
Preparations before Use	26
Verifying the Power Supply	26
Setting up the Fuse	26
Verifying and Connecting the Power Cable	27
How to Remove the Handle	29
Caution when Using the Handle	30
Environmental Requirements	31
Operating Environments	31
Ventilation Requirements	32
Protection Against Electrostatic Discharge (ESD)	33
Ensuring Adequate Free Space around the LCR meter for Immediate Disconnection of the Power Cable in Case of Emergency	33
Starting the E4980A	34
Turning the Power ON and OFF	34
Disconnecting from the Supply Source	35

2. Overview

Product Introduction	38
Front Panel: Names and Functions of Parts	39
1. Power switch	40
2. LCD	40
3. Softkeys	40
4. Menu keys	40
5. Cursor keys	40
6. Entry keys	40
7. LED indicator	41
8. Preset key	41
9. Trigger key	41
10. DC Bias key	41
11. DC Source key	41
12. UNKNOWN terminals	41
13. Front USB port	42
14. Ground terminal	42
15. DC Source terminal	42
Rear Panel: Names and Functions of Parts	43
1. GPIB Interface Connector	43
2. Interface Connector	43
3. USB (USBTMC) Interface Port	44
4. LAN Port	44
5. External Trigger Input Connector	44
6. Serial Number Plate	44
7. Power Cable Receptacle (to LINE)	44
8. Fan	45
Screen Area: Names and Functions of Parts	46
1. Display Page Area	46
2. Comment Line Area	46
3. Softkey Area	47

4. Measurement Data/Conditions Area.	47
5. Input Line Area.	48
6. System Message Area.	48
7. Status Display Area.	48
Basic Operation	49
How to Use Cursor Keys	49
How to Use Skip Keys	50
3. Display Format	
MEAS DISPLAY Page.	52
Measurement Function	54
Impedance range	57
Test Frequency	64
Test Signal Level.	66
DC Bias.	69
Measurement Time Mode	73
Display Setting for Measurement Results	74
Displaying Errors instead of Measurement Results	76
Monitor Information	79
BIN NO. DISPLAY Page.	80
Comparator Function ON/OFF.	81
BIN COUNT DISPLAY Page	82
Counter Function	83
LIST SWEEP DISPLAY Page	84
Sweep Mode	85
DISPLAY BLANK Page	87
4. Configuring Measurement Conditions (Display and Function Related Settings)	
Initializing the Instrument	90
MEAS SETUP page	91
Comment line	93
Trigger mode.	94
Automatic level control	96
DC Bias Current Isolation.	100
Averaging Factor.	101
Trigger Delay Time.	102
Step Delay Time	104
DC Bias Voltage Monitor	106
DC Bias Current Monitor	107
DCR Range.	108
DCI Range	109
DC Source.	110
Automatic Bias Polarity Control	111
Deviation Measurement	113
CORRECTION page	115
To set the correct function to on or off	116
The correction functions of the E4980A are operated as follows:	117
Open Correction	118

Short Correction	121
Correction Based on User-Specified Frequency Points	123
Relationships between Correction Based on All Frequency Points and Correction Based on Specified Frequency Points	127
Reading/Writing Correction Data	129
Measurement Functions for the Standard	130
Selecting Single/Multiple Correction Mode	131
Selecting the Cable Length	132
LIMIT TABLE SETUP Page	133
Parameter Swap Feature	134
Comparator Limit Mode	136
Tolerance Mode Nominal Value	138
Turning On/Off the Comparator	139
Turning On/Off the Auxiliary Bin.	140
Beep Feature	142
Lower and Upper Limits	143
LIST SWEEP SETUP Page	146
Sweep Mode	147
List Sweep Parameters	148
Sweep Points and Limit Modes.	149
Sweep Parameter Auto-completion.	152
5. System Configurations	
SYSTEM INFO Page	156
Bias Current Interface	157
Handler Interface.	158
Scanner Interface.	159
Monitor Information	159
SYSTEM CONFIG Page	160
Turning On/Off the Beep Feature	161
Changing the Beep Tone	162
Changing the Beep Tone	163
Configuring the Time Zone.	164
Configuring the System Date	165
Configuring the GPIB Address	167
Configuring the LAN IP address.	168
SELF TEST Page	171
Choosing a Test Item.	172
SERVICE Page	173
Monitor Information	174
Saving the System Information into External Memory	174
6. Save/Recall	
Overview of Save/Recall Functionality	176
Save Methods and Their Uses.	176
Folder/File Structure on USB Memory	176
USB Memory Notes	177
Saving/Recalling Instrument Configuration States.	178

Overview of Instrument Configurations	178
Medium Mode	179
Choosing a Register Number	180
Memory Status Information	180
Comment Information	181
Saving/Recalling Instrument Configuration States into/from the Internal Memory	181
Saving/Recalling Instrument Configuration States into/from USB Memory	183
Using the Auto Recall Feature	185
Saving Measurement Results into USB Memory	186
Measurement Result Format	186
To save measurement results into USB memory:	189
How to save the measurement result of List Sweep Measurement to USB memory.	190
Saving a Screenshot into USB Memory	191
To save a screenshot into USB memory	191
7. Measurement Procedure and Examples	
Basic Measurement Procedure	194
Impedance Parameters	195
Parallel/Series Circuit Mode	198
Selecting Circuit Mode of Capacitance	199
Selecting Circuit Mode of Inductance	199
Test Signal Level	201
Test Signal Level Across the DUT	201
Test Signal Level Setting	202
Four-Terminal Pair Configuration	203
Measurement Contacts	204
Capacitance to Ground	204
Contact Resistance	206
Extending Test Leads	207
Guarding for Measurement of Low Capacitance Values	209
Shielding	210
Correction Functions	211
Performing OPEN Correction	212
Performing SHORT Correction	213
Performing LOAD Correction	213
Parasitics Incident to DUT Connection	215
Characteristics Example	216
Capacitor Measurements	218
Inductance Measurements	221
Measurements Using DC source	223
8. Overview of Remote Control	
Types of remote control system	226
GPIB remote control system	227
What is GPIB?	227
System configuration	227
Device selector	228
LAN remote control system	229

System configuration.	229
Control over SICL-LAN server.	230
Control over telnet server	235
Control via Web server	238
USB Remote Control System	241
System configuration.	241
Sending SCPI command messages	248
Types and structure of commands.	248
Grammar of messages	249
Remote mode.	250
Trigger System	251
System-wide states and transitions	251
Data Buffer Memory.	257
Data Buffer Memory	257
When Data Buffer Memory is Used	258
Output Format of Data Buffer Memory	259
Starting a Measurement Cycle (triggering the instrument).	261
Configuring the instrument to automatically perform continuous measurement	261
Starting Measurement on Demand	261
Waiting for the End of Measurement	263
Using the status register	263
Data Transfer.	265
Data Format.	265
Status Byte	271
Enabling the Status Byte	273
Operation Status Register Structure	274
Standard Event Status Register	277
Enabling the Event Status Register	279

9. SCPI Command Reference

Notational conventions in this command reference	282
Syntax	282
Description	282
Parameters	283
Equivalent key	283
E4980A commands	284
*CLS	284
*ESE	284
*ESR?	284
*IDN?	284
*LRN?	285
*OPC	285
*OPC?	285
*OPT?	285
*RST	285
*SRE	286
*STB?	286
*TRG	286
*TST?	286

Contents

*WAI	286
:ABORt	287
:AMPLitude:ALC	287
:APERture	287
:BIAS:CURRent[:LEVel]	288
:BIAS:POLarity:AUTO	288
:BIAS:POLarity:CURRent[:LEVel]?	289
:BIAS:POLarity:VOLtage[:LEVel]?	289
:BIAS:RANGe:AUTO	289
:BIAS:STATe	290
:BIAS:VOLtage[:LEVel]	290
:COMParator:ABIN	291
:COMParator:BEEPer	291
:COMParator:BIN:CLEar	291
:COMParator:BIN:COUNT:CLEar	292
:COMParator:BIN:COUNT:DATA?	292
:COMParator:BIN:COUNT[:STATe]	292
:COMParator:MODE	292
:COMParator:SEQuence:BIN	293
:COMParator:SLIMit	294
:COMParator[:STATe]	294
:COMParator:SWAP	294
:COMParator:TOLerance:BIN[1-9]	295
:COMParator:TOLerance:NOMinal	295
:CONTRol:CBias:STATe	295
:CONTRol:HANDler:STATe	296
:CONTRol:SCANner:STATe	296
:CORRection:LENGth	297
:CORRection:LOAD:STATe	297
:CORRection:LOAD:TYPE	297
:CORRection:METHod	298
:CORRection:OPEN[:EXECute]	299
:CORRection:OPEN:STATe	299
:CORRection:SHORT[:EXECute]	299
:CORRection:SHORT:STATe	299
:CORRection:SPOT[1-201]:FREQuency	300
:CORRection:SPOT[1-201]:LOAD[:EXECute]	300
:CORRection:SPOT[1-201]:LOAD:STANdard	300
:CORRection:SPOT[1-201]:OPEN[:EXECute]	301
:CORRection:SPOT[1-201]:SHORt[:EXECute]	301
:CORRection:SPOT[1-201]:STATe	301
:CORRection:USE[:CHANnel]	302
:CORRection:USE:DATA[:MULTi]	302
:CORRection:USE:DATA:SINGle	303
:CURRent[:LEVel]	303
:DISPlay:CClear	304
:DISPlay:ENABle	304
:DISPlay:LINE	304
:DISPlay:PAGE	305

:DISPlay[:WINDow]:TEXT[1-2][:DATA]:FMSD:DATA	306
:DISPlay[:WINDow]:TEXT[1-2][:DATA]:FMSD[:STATe]	306
:FETCh[:IMPedance]:CORReCted?	307
:FETCh[:IMPedance][:FORMatted]?	307
:FETCh:SMONitor:IAC?	307
:FETCh:SMONitor:IDC?	307
:FETCh:SMONitor:VAC?	307
:FETCh:SMONitor:VDC?	308
:FORMat:ASCIi:LONG	308
:FORMat:BORDer	308
:FORMat[:DATA]	309
:FREQuency[:CW]	309
:FUNCTion:DCResistance:RANGe:AUTO	309
:FUNCTion:DCResistance:RANGe[:VALue]	310
:FUNCTion:DEV[1-2]:MODE	310
:FUNCTion:DEV[1-2]:REFerence:FILL	311
:FUNCTion:DEV[1-2]:REFerence[:VALue]	311
:FUNCTion:IMPedance:RANGe:AUTO	311
:FUNCTion:IMPedance:RANGe[:VALue]	312
:FUNCTion:IMPedance[:TYPE]	312
:FUNCTion:SMONitor:IAC[:STATe]	313
:FUNCTion:SMONitor:IDC[:STATe]	314
:FUNCTion:SMONitor:VAC[:STATe]	314
:FUNCTion:SMONitor:VDC[:STATe]	315
:HCOPy:SDUMp:DATA	315
:INITiate:CONTInuous	316
:INITiate[:IMMEdiate]	316
:LIST:BAND[1-201]	316
:LIST:BIAS:CURRent	317
:LIST:BIAS:VOLTagE	317
:LIST:CLear:ALL	318
:LIST:CURRent	318
:LIST:DCSource:VOLTagE	318
:LIST:FREQuency	319
:LIST:MODE	319
:LIST:SEQuence:TSTamp:CLear	320
:LIST:SEQuence:TSTamp:DATA	320
:LIST:STIMulus:DATA	320
:LIST:STIMulus:MDATa?	321
:LIST:STIMulus:TYPE	321
:LIST:VOLTagE	322
:MEMory:CLear	322
:MEMory:DIM	323
:MEMory:FILL	323
:MEMory:READ?	323
:MMEMory:DELeTe[:REGister]	323
:MMEMory:LOAD:STATe[:REGister]	324
:MMEMory:STORe:STATe[:REGister]	324
:OUTPut:DC:ISOLation:LEVel:AUTO	324

:OUTPut:DC:ISOLation:LEVel:VALue	325
:OUTPut:DC:ISOLation[:STATe].	325
:OUTPut:HPOWer	326
:SOURce:DCSource:STATe	326
:SOURce:DCSource:VOLTagE[:LEVel].	326
:STATus:OPERation:CONDition?	327
:STATus:OPERation:ENABle	327
:STATus:OPERation[:EVENT]	327
:SYSTem:BEEPer[:IMMediate]	327
:SYSTem:BEEPer:STATe	328
:SYSTem:BEEPer:TONE	328
:SYSTem:COMMunicate:GPIB[:SELF]:ADDRess	329
:SYSTem:COMMunicate:LAN[:SELF]:ADDRess	329
:SYSTem:COMMunicate:LAN[:SELF]:AIP[:STATe].	329
:SYSTem:COMMunicate:LAN[:SELF]:CONFigure	330
:SYSTem:COMMunicate:LAN[:SELF]:CONTRol	330
:SYSTem:COMMunicate:LAN[:SELF]:CURRent:ADDRess?	330
:SYSTem:COMMunicate:LAN[:SELF]:CURRent:DGATeway?.	331
:SYSTem:COMMunicate:LAN[:SELF]:CURRent:SMASK?.	331
:SYSTem:COMMunicate:LAN[:SELF]:DGATeway	331
:SYSTem:COMMunicate:LAN[:SELF]:DHCP[:STATe].	331
:SYSTem:COMMunicate:LAN[:SELF]:MAC?	332
:SYSTem:COMMunicate:LAN[:SELF]:PRESet	332
:SYSTem:COMMunicate:LAN[:SELF]:REStart	332
:SYSTem:COMMunicate:LAN[:SELF]:SMASK	332
:SYSTem:DATE	333
:SYSTem:ERRor[:NEXT]?.	333
:SYSTem:KLOCK	334
:SYSTem:PRESet	334
:SYSTem:REStart	334
:SYSTem:TIME	334
:SYSTem:TZONE	335
:TRIGger:DELay	336
:TRIGger[:IMMediate].	336
:TRIGger:SOURce	336
:TRIGger:TDEL	337
:VOLTagE[:LEVel]	337
Command list	338
List by function	338
Command Tree	343
Softkey Functions	351
Data Processing	365
10. Sample Program	
Set Up Measurement Conditions and LCD Display	368
Detecting End of Measurement	371
Read Measurement Results	374
Read measurement data in ASCII format (Comparator)	374
Read measurement data in ASCII format (Data buffer memory)	377

Read measurement data in ASCII format (List sweep)	380
Read measurement data in BINARY (comparator)	383
Read measurement data in BINARY format (Data buffer memory)	386
Read measurement data in BINARY format (List sweep)	389
Save/Recall	392
Read/Write correction data at specified frequency points	394

11. Specifications and Supplemental Information

Definitions	400
How to Use Tables	400
Basic Specifications	401
Measurement Functions	401
Test signal	403
Measurement display ranges	404
Absolute measurement accuracy	405
Relative accuracy	408
Calibration accuracy A_{cal}	415
Measurement accuracy	417
Correction function	418
List sweep	418
Comparator function	419
DC bias signal	419
Measurement assistance functions	420
Options	421
Option 001 (Power and DC Bias enhancement)	421
Other options	429
General specifications	430
Power source	430
Operating environment	430
Storage environment	430
Outer dimensions	430
Weight	433
Display	433
EMC, Safety, and Environment	435
Supplemental Information	436
Settling time	436
Measurement circuit protection	436
Measurement time	437
Display time	440
Measurement data transfer time	441
DC bias test signal current (1.5 V / 2.0 V)	441
Option 001 (Power and DC Bias enhancement)	441
When DC bias is applied to DUT	443
Relative measurement accuracy with bias current isolation	443
DC bias signal	445
DC bias settling time	446

12. Precautions for Use and Daily Checks

Contents

Precautions for Use	448
Avoiding improper input from the front panel (key lock function)	448
Daily Checks (Executing the self-test)	449
Self-test at power on	449
Executing the self-test from the front panel	449
Cleaning this Instrument.	451
Unknown Terminals/DC Source Ports	451
Cleaning Parts Other than Unknown Terminals and DC Source Ports.	451
Cautions Applicable to Requesting Repair, Replacement, Regular Calibration, etc.	452
Caution when Sending the Unit	452
Recommended Calibration Period	452
13. Troubleshooting	
Check Items When Trouble Occurs	454
The system does not start up (Nothing is displayed)	454
The system starts up, but the normal measurement screen does not appear (Service Mode).	454
An overload message is displayed	454
Beeping persists when turning on the comparator function	454
The front panel keys are unavailable	455
Clearly abnormal measured value.	455
Saving to USB memory fails	455
An error message or warning message is displayed	455
Check Items When Trouble Occurs During Remote Control.	456
The instrument does not respond to the external controller or malfunctions	456
You cannot read out the measured value.	456
An error message is displayed	456
A. Manual Changes	
Manual Changes	458
Change 3	459
Change 2	459
Change 1	459
B. Error Messages	
Error Messages	462
A	462
B	462
C	462
D	463
E	464
F	464
G	465
H	465
I	465
M	466
N	466
O	467
P	467

Q	467
R	468
S	468
T	468
U	469
V	469
Warning Messages	470
Numeric	470
A	470
C	470
I	471
S	471
C. List of Default Values	
List of Default Values, Save/Recall Settings, and Backup Settings	474
List of Default Values	475
List of LAN Factory Default Settings	478
D. Bias Current Interface	
Product Overview	480
42841A Bias Current Source	480
Operation Limitations	480
Specifications when Measuring with the 42841A	481
Preparation	482
Equipment Requirements	482
Cable Connection	482
Measurement Procedures	486
E. Scanner Interface	
Overview	488
Specifications	489
Specifications	489
Supplemental Performance Characteristics	489
Signal Input/Output Connector	490
Scanner Interface Input/Output Signals	490
Scanner Interface I/O Connector Pin Assignments	492
Timing Chart	494
Electrical Characteristics of the Input/Output Signals	497
Channel Selection Input Signals	497
External Trigger Input Signals	497
Control Output Signals	500
Setting Up the Scanner Interface Board	501
How to Use the Scanner Interface Board	503
Basic Procedure	503
Activating Scanner Interface	505
Correction Mode	505
Test Frequency and Reference Value Entry	505
Correction Data Selection	506

Correction Data Measurements	508
Activating the Correction Function	509
Correction Data Confirmation	509
F. Handler Interface	
Overview	512
Specifications	513
Output Signals.	513
Input Signals	513
Signal Line Definitions.	514
Signal Line Definitions for the Comparator	514
Signal Line Definitions for the List Sweep Comparator	520
Electrical Characteristics	525
DC Isolation Output Signals	525
DC isolation input signals (photo-coupled)	527
Setting Up the Handler Interface Board.	530
Using the Handler Interface	536
Setting Up the Handler Interface for Use with the Comparator	536
Setting Up the Handler Interface Board for Use with the List Sweep Comparator	537
Signals Activated when Overload Occurs	538
G. Functional Comparison between 4284A, 4279A and E4980A	
Functional Comparison between 4284A, 4279A, and E4980A	540

1 Unpacking and Preparation

This chapter describes how to set up and start the Agilent E4980A Precision LCR Meter.

Contents of this Chapter

- o **Checking the Shipment** on page 23
After you receive the E4980A, check all the items in the packing container.
- o **Preparations before Use** on page 26
Shows how to check the power supply as well as check and connect the power cable. This section also describes how to deal with a blown fuse.
- o **How to Remove the Handle** on page 29
Shows how to attach and remove the handle.
- o **Environmental Requirements** on page 31
Describes the system requirements needed to install the E4980A and how to secure space for heat radiation.
- o **Starting the E4980A** on page 34
Describes how to turn on/off the power switch and cut off the power supply.

Checking the Shipment

After you receive the E4980A, carry out checks during unpacking according to the following procedure.

WARNING

If the external face of the LCR meter (such as the cover, front/rear panel, LCD screen, power switch, and port connectors) appears to have been damaged during transport, do not turn on the power switch. Otherwise, you may get an electrical shock.

-
- Step 1.** Check that the packing box or shock-absorbing material used to package the LCR meter has not been damaged.

NOTE

If the packing box or shock-absorbing material has been damaged, leave the packing box and shock-absorbing material as is until other inspection items are checked as follows:

- Step 2.** Check the packaged items supplied with the LCR meter for any damage or defects.
- Step 3.** Referring to Table 1-1 and Figure 1-1, check that all packaged items supplied with the LCR meter have been provided as per the specified options.
- Step 4.** After checking, if one of the following applies, contact your nearest Agilent Technologies sales and service office.
1. The packing box or shock-absorbing material used to package the LCR meter has been damaged or the shock-absorbing material displays traces of where extreme pressure has been applied.
 2. A packaged item supplied with the LCR meter has mechanical damage or defects.
 3. A packaged item supplied with the LCR meter is missing.
 4. A fault has been detected in the subsequent operation check of the LCR meter.

If an abnormality is detected in Step 1, contact the company that transported the LCR meter as well as your nearest Agilent Technologies sales and service office. For inspection by the transport company, save the packing box, shock-absorbing material, and packaged items as you received them.

Table 1-1 **Items Packaged with the E4980A**

Name	Product/Part Number	Qty
Standard Accessories		
o E4980A	E4980A	1
o Power cable *1	8120-4753	1
o USB Cable	82357-61601	1
o CD-ROM (of the manual and the sample program)	See footnote *2	1
o CD-ROM (of the Agilent IO Libraries suite)	See footnote *2	1
Options		
o Manual (Option ABA)		
• User's Guide	See footnote *2	1
o Rack mount kit without handles (Option 1CM) *3	5063-9241	1
o Adapter (Option 002) *4	E4980-60102	1

*1. This accessory varies from country to country. For the power cable option, see Table 1-3. A 3p-2p conversion adapter is not supplied.

*2. The LCR meter will always be supplied with the latest versions of these items.

*3. This accessory is not shown in Figure 1-1. For how to install the rack mount kit, refer to the attached manual.

*4. This accessory is not shown in Figure 1-1.

Figure 1-1

E4980A Accessories

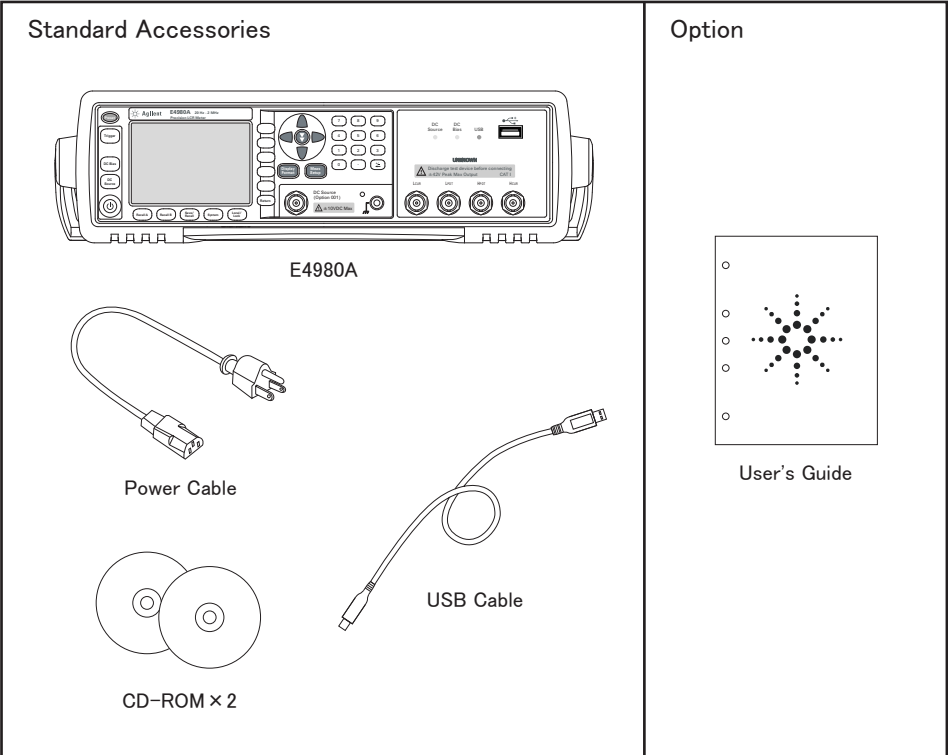

e4980aue1022

Preparations before Use

Verifying the Power Supply

Confirm that the power supplied to the E4980A meets the following requirements:

Table 1-2

	Requirements
Voltage	90 to 132 Vac or 198 to 264 Vac *1
Frequency	47 to 63 Hz
Maximum power consumption	150 VA

*1. Switched automatically by the E4980A in conformity with the voltage used.

Setting up the Fuse

Please use the following fuse type.

UL/CSA type, Slo-Blo, 5×20-mm miniature fuse, 3 A, 250 V (Agilent part number 2110-1017)

When you need a fuse, contact your nearest Agilent Technologies sales and service office. To verify and replace the fuse, remove the power cable and pull out the fuse holder.

Figure 1-2

Fuse Holder and Power Cable Receptacle

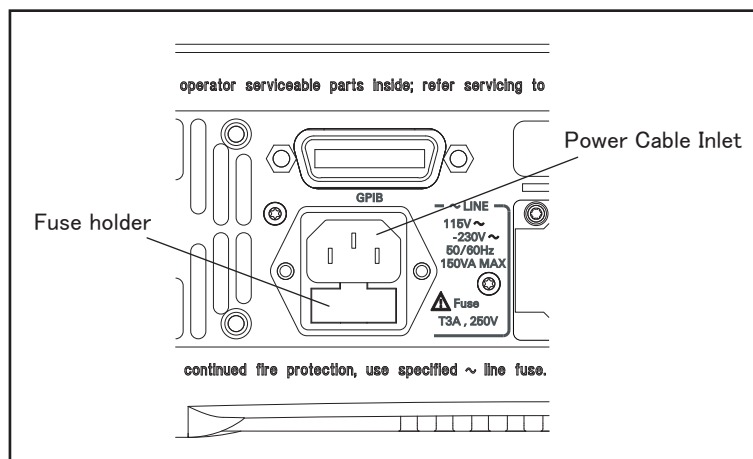

e4980aue1008

Verifying and Connecting the Power Cable

The three-wire power cable attached to the E4980A has one wire serving as a ground. Using this power cable allows the E4980A to be grounded, thereby protecting you against electrical shock from the power outlet.

Step 1. Confirm that the power cable is not damaged.

WARNING Never use a power cable showing any sign of damage. Faulty cables can cause electric shock.

Step 2. Use the supplied cable to connect the power cable receptacle on the rear panel of the E4980A to a three-wire power outlet with the grounding prong firmly held in the ground slot.



WARNING Use the supplied three-wire power cable with a grounding wire to securely ground the E4980A.

NOTE A 3p-2p conversion adapter is not supplied with the LCR meter. When you need a 3p-2p conversion adapter, contact your nearest Agilent Technologies sales and service office listed in the back of this manual.

Figure 1-3 shows the power cable options.

Unpacking and Preparation
Preparations before Use

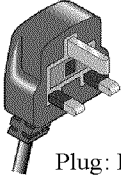
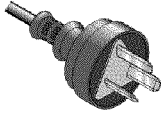
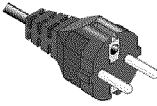
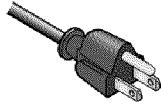
Figure 1-3 Power cable options

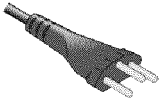
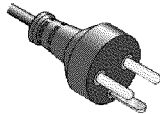
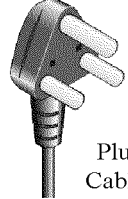
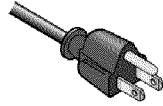
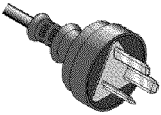
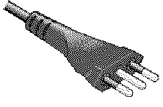
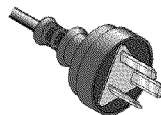
<p>OPTION 900</p>  <p>United Kingdom</p> <p>Plug: BS 1363/A, 250V, 10A Cable: 8120-1351, 8120-8705</p>	<p>OPTION 901</p>  <p>Australia/New Zealand</p> <p>Plug: AS 3112, 250V, 10A Cable: 8120-1369</p>
<p>OPTION 902</p>  <p>Continental Europe</p> <p>Plug: CEE 7 Standard Sheet VII, 250V, 10A Cable: 8120-1689</p>	<p>OPTION 903</p>  <p>U.S./Canada</p> <p>Plug: NEMA 5-15P, 125V, 10A Cable: 8120-1378</p>
<p>OPTION 904</p>  <p>U.S./Canada</p> <p>Plug: NEMA 6-15P, 250V, 6A Cable: 8120-0698</p>	<p>OPTION 906</p>  <p>Switzerland</p> <p>Plug: SEV Type 12, 250V, 10A Cable: 8120-2104</p>
<p>OPTION 912</p>  <p>Denmark</p> <p>Plug: SR 107-2-D, 250V, 10A Cable: 8120-2956</p>	<p>OPTION 917</p>  <p>India/Republic of S. Africa</p> <p>Plug: IEC 83-B1, 250V, 10A Cable: 8120-4211</p>
<p>OPTION 918</p>  <p>Japan</p> <p>Plug: JIS C 8303, 125V, 12A Cable: 8120-4753</p>	<p>OPTION 920</p>  <p>Argentina</p> <p>Plug: Argentine Resolution 63, Annex IV, 250V, 10A Cable: 8120-6870</p>
<p>OPTION 921</p>  <p>Chile</p> <p>Plug: CEI 23-16, 250V, 10A Cable: 8120-6978</p>	<p>OPTION 922</p>  <p>China</p> <p>Plug: GB 1002, 250V, 10A Cable: 8120-8376</p>
<p>NOTE: Each option number includes a 'family' of cords and connectors of various materials and plug body configurations (straight, 90° etc.).</p>	

power_e

How to Remove the Handle

A handle kit is attached to the E4980A. When using the E4980A with the rack-mount kit, remove the handle according to the following steps.

Figure 1-4

How to remove the handle

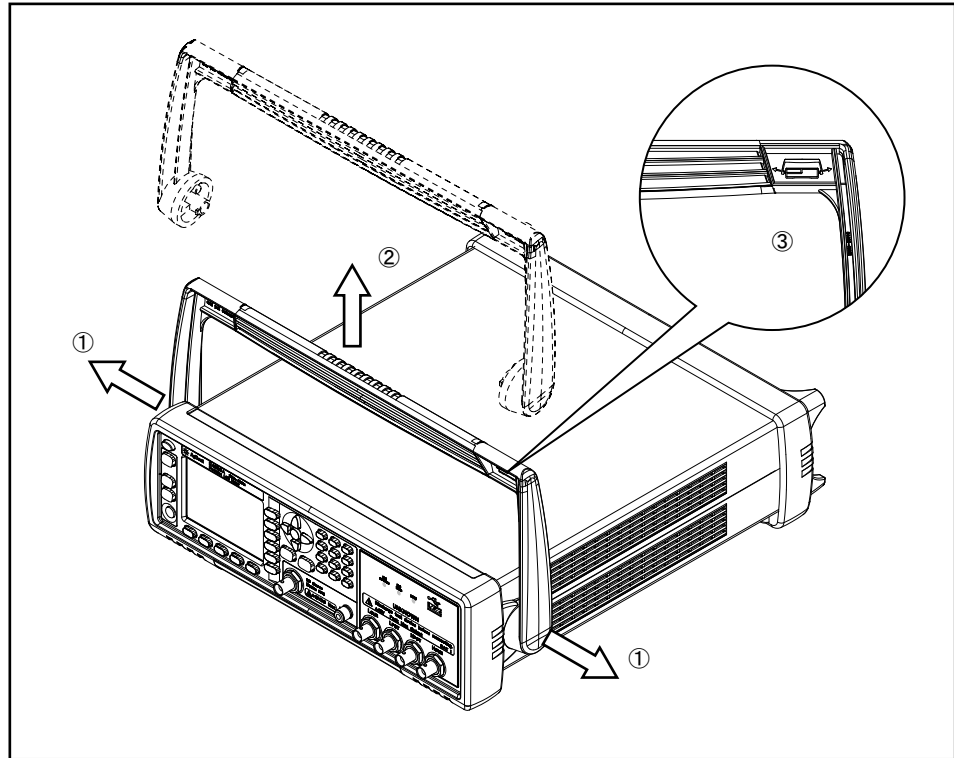

e4980auj1151

Step 1. Lift the handle perpendicular to the unit while pulling it in the direction of 1.

Step 2. While pulling the handle in the direction of 1, lift towards 2.

NOTE

Install the handle with 3 facing toward the front. Installing the handle the other way around may damage it.

Caution when Using the Handle

Follow the instructions below when using the E4980A's handle, otherwise you may get your fingers caught in the handle or the E4980A may fall and be damaged

- When the handle is set up as shown in Figure 1-5, do not put any additional weight onto the E4980A or lift it suddenly.
- Do not touch the handle while the DUT is attached.

Figure 1-5

The handle in the set-up position

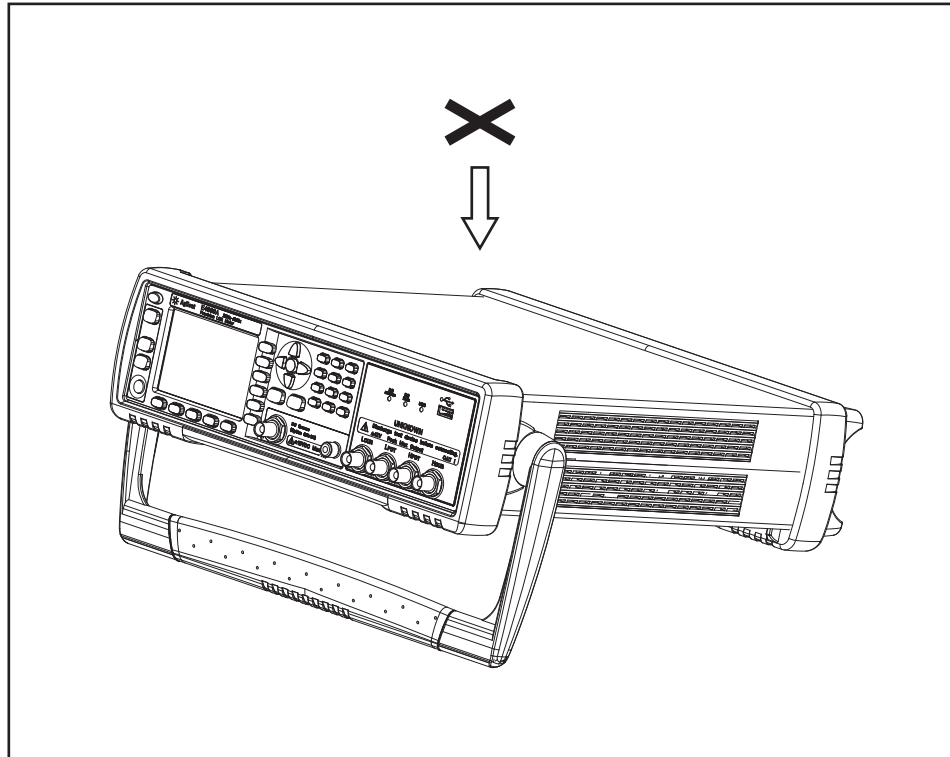

e4980auj1175

Environmental Requirements

Set up the E4980A where the following environmental requirements are satisfied.

Operating Environments

Ensure that the operating environment meets the following requirements.

Table 1-3

Temperature	0°C to 55°C
Temperature range at calibration	23°C ± 5°C (<1°C deviation from the temperature when performing calibration)
Humidity	15% to 85% at wet bulb temperature ≤ 40°C (non-condensation)
Altitude	0 to 2,000 m (0 to 6,561 feet)
Vibration	Max. 0.5 G, 5 Hz to 500 Hz

CAUTION

The environmental requirements listed above are NOT for the specifications and measurement accuracy of the E4980A, but for its operating environment.

Ventilation Requirements

To ensure that the safety requirements, the specifications, and the measurement accuracy of the LCR meter are met, you must maintain the environmental temperature to within the specified range by providing an appropriate cooling clearance around the LCR meter or, for the rack-mounted type, by forcefully air-cooling inside the rack housing. For more information on environmental temperatures that satisfy the specifications and measurement accuracy of the LCR meter, see Chapter 11, “Specifications and Supplemental Information,” on page 399.

The LCR meter conforms to the requirements of the safety standard. When the environmental temperature around the LCR meter is kept within the temperature range of the operating environment specifications (“Operating Environments” on page 31).

The LCR meter still conforms to the requirements of the safety standard it is installed with the following cooling clearance:

	Requirements
Back	≥ 180 mm
Sides	≥ 60 mm (both right and left)

Figure 1-6

Ventilation space at installation

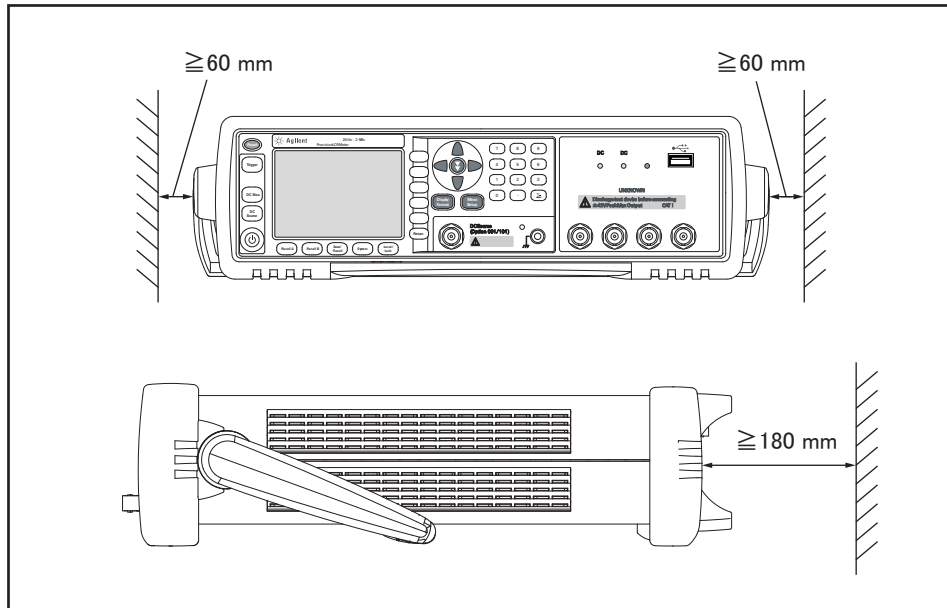

e4980auj1029

Protection Against Electrostatic Discharge (ESD)

Figure 1-7 shows the setup for a static-safe work station to protect the electronic components from damage by electrostatic discharge (ESD).

Figure 1-7

Example of a static-free work station

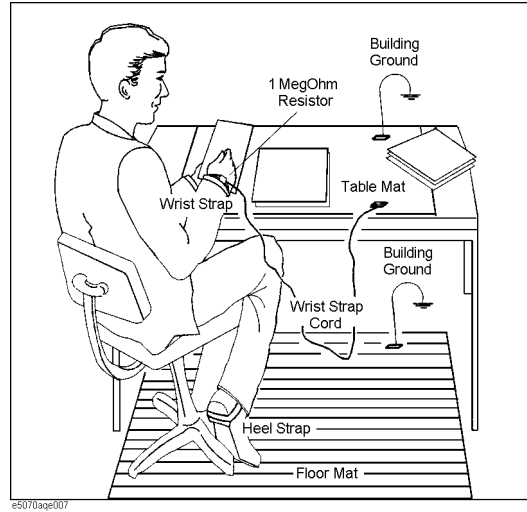

Ensuring Adequate Free Space around the LCR meter for Immediate Disconnection of the Power Cable in Case of Emergency

As described in “Disconnecting from the Supply Source” on page 35, the plug attached to the power cable serves as the disconnecting device (device that cuts off the power supply) for the E4980A. When installing the E4980A, ensure that there is sufficient free space around the unit to permit quick disconnection of the plug (from the AC outlet or the E4980A unit) in case of emergency.

Starting the E4980A

This section describes how to turn on/off the E4980A power and how to cut off the power supply in an emergency.

Turning the Power ON and OFF

Turning the Power ON



The ON and OFF status of the power switch  is confirmed by the color of the  switch.

Table 1-4

Color of the light	Status of the power
Orange	Power on
Yellow-green	Power off
Light off	Power off (The power supply is cut off)

Step 1. Confirm that the power switch light  in the lower-left part of the front panel is lit in orange. If the light is off, the power supply may also be off.

Step 2. Press the power switch. When the light of the power switch turns yellow-green, the power is turned ON and the E4980A starts the self-test.

The self-test takes approx. 30 seconds.

Step 3. Confirm that the self-test indicates normal operation.

Normal operation is confirmed by the self-test if no error message appears.

Turning the Power OFF

Step 1. Follow the method below to turn the power OFF.

- Press the power switch  in the lower-left part of the front panel.

NOTE

Do not turn the power OFF while saving into or recalling from the internal memory of the E4980A or the USB memory. Doing so may clear the contents from the memory.

Disconnecting from the Supply Source

The plug attached to the power cable (on the power outlet side or device side of the cable) serves as the disconnecting device (device that cuts off the power supply) of the E4980A. When the power supply must be cut off to avoid such danger as electric shock, pull out the power cable's plug (on the power outlet side or device side of the cable).

NOTE

To allow this operation to be performed smoothly, be sure to follow the guidelines in “Ensuring Adequate Free Space around the LCR meter for Immediate Disconnection of the Power Cable in Case of Emergency” on page 33.

When turning the power OFF under normal circumstances, always follow the methods described in “Turning the Power OFF” on page 34.

Unpacking and Preparation
Starting the E4980A

2 Overview

This chapter provides the basic procedures for operating the E4980A and describes names and functions of the front panel, rear panel, and screen display.

Product Introduction

The Agilent E4980A is a general-purpose LCR meter for incoming inspection of components, quality control, and laboratory use. The E4980A is used for evaluating LCR components, materials, and semiconductor devices over a wide range of frequencies (20 Hz to 20 MHz) and test signal levels (0.1 mVrms to 2 Vrms, 50 μ A to 20 mArms). With Option 001, the E4980A's test signal level range spans 0.1 mV to 20 Vrms, and 50 μ A to 200 mArms. Also, the E4980A with Option 001 enables up to ± 40 -Vrms DC bias measurements (without Option 001, up to ± 2 Vrms), DCR measurements, and DC source measurements using the internal voltage source.

The E4980A offers C-D measurement with a basic accuracy of $\pm 0.05\%$ (C), ± 0.0005 (D) at all frequencies with seven-digit resolution (the dissipation factor resolution is 1 ppm) in every range.

With its built-in comparator, the E4980A can output comparison/decision results for sorting components into a maximum of ten bins. Furthermore, by using the handler interface and scanner interface options, the E4980A can be easily combined with a component handler, a scanner, and a system controller to fully automate component testing, sorting, and quality-control data processing.

The E4980A's list sweep function permits entry of up to 201 frequencies, test signal levels, or bias level points to be automatically measured.

The GP-IB/LAN/USB interfaces are standard interfaces on the E4980A and enable automatic testing.

Front Panel: Names and Functions of Parts

This section describes the names and functions of the parts on the E4980A's front panel. For more details on the functions displayed on the LCD screen, see "Screen Area: Names and Functions of Parts" on page 46. For more about the functions of softkeys, see "Softkey Functions" on page 351.

Figure 2-1

Front panel

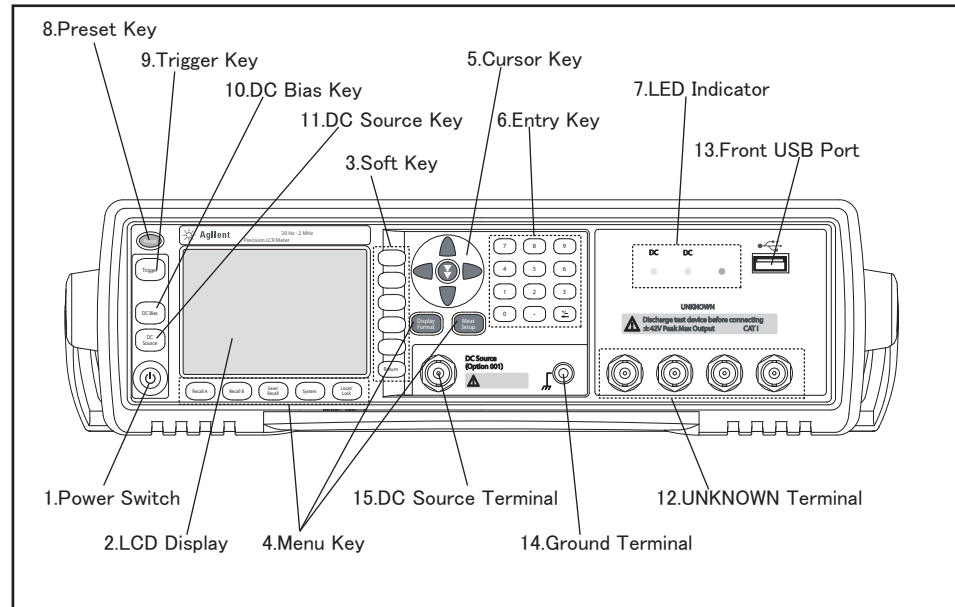

e4980aue1012

WARNING



A maximum of 52 V of hazardous voltage between terminals might be present when the LED indicator for DC Bias or DC Source lights up. Do NOT touch UNKNOWN terminals, DC source terminals, or electrodes of test fixtures.

Turn off the output of DC Bias and DC source and confirm that LED indicators are off when setting up the E4980A and its accessories.

1. Power switch

Used for choosing between power-on and -off states of the E4980A. When turned on, the switch lights up in yellow-green and all operating voltages are applied to the instrument. When turned off, the switch lights up in orange and no operating voltages are applied to the instrument.

2. LCD

The Liquid Crystal Display (LCD) displays measurement results, test conditions, etc.

NOTE

Occasionally there are missing pixels or constantly lit pixels, but this is not a malfunction and does not affect the performance of your product.

3. Softkeys

Five softkeys are used to select measurement conditions and parameter functions. Each softkey has a softkey label along its left side.

4. Menu keys

Menu selection keys are used to access the corresponding selection of instrument controls.

Table 2-1

[Display Format] key	Displays measurement results and selections.
[Meas Setup] key	Sets measurement conditions, a correction function, and limit values for BIN sorting.
[Recall A] key	Recalls the setting information on internal memory 0.
[Recall B] key	Recalls the setting information on internal memory 1.
[Save/Recall] key	Saves and recalls the setting information. Saves measurement results and screen images.
[System] key	Sets the system. Sets the GP-IB interface and LAN. Performs a self-test.
[Local/Lock] key	Locks and unlocks hard keys and softkeys on the front panel. Cancels remote control with GPIB commands.

5. Cursor keys

Keys used to move the field select cursor from field to field on a displayed page. When the cursor is moved to a certain field, that field changes to an inverse video image of the original field. The cursor can only be moved from field to field.

For the skip key, refer to the “How to Use Skip Keys” on page 50.

6. Entry keys

Keys used to enter numeric data into the E4980A. The entry keys comprise the digits 0 to 9, a period (.), and a plus/minus (+/-) sign. Entered values are displayed on the input line

(second line from the bottom of the LCD screen), and pressing the softkey terminates numeric input. The plus/minus key deletes the last character of the input value.

7. LED indicator

The LED indicator lights up when DC Bias or DC Source is on. The USB indicator lights up while accessing a USB memory.

8. Preset key

A key used to return the LCR meter to the initial setup state. There are three methods for initialization. For details, refer to “Initializing the Instrument” on page 90.

9. Trigger key

A key used to manually trigger the E4980A when it is set to the manual trigger mode.

10. DC Bias key

A key used to toggle on and off of the DC bias output. When the DC bias output is set to on, the DC bias indicator lights up and DCBIAS is displayed in the status display area on the screen.

If the DC Bias key is set to off, even though the DC bias is set to on according to the LCD display, the DC bias is not output.

NOTE

Regardless of which page is displayed, when the DC BIAS key is pressed, the value that has been set in the BIAS field of MEAS SETUP (and MEAS DISPLAY) is output. For example, in case that DC Bias sweep has been set with the LIST SWEEP DISPLAY page displayed, the value set in the BIAS field is output when the DC BIAS key is pressed. Then, after the E4980A is triggered, the DC Bias is set according to the list that has been set.

11. DC Source key

A key used to toggle on and off of the DC source output. When the DC source output is set to on, the DC Source indicator lights up and DCSRC is displayed in the status display area on the screen.

NOTE

Option 001 is required for this function.

NOTE

Regardless of which page is displayed, when the DC SOURCE key is pressed, the value that has been set in the DC SRC field of MEAS SETUP is output. For example, in case that DC SRC sweep has been set with the LIST SWEEP DISPLAY page displayed, the value set in the DC SRC field is output when the DC SRC key is pressed. Then, after the E4980A is triggered, the DC Source is set according to the list that has been set.

12. UNKNOWN terminals

These are the UNKNOWN terminals used to connect a four-terminal pair test fixture or test leads for measuring the device under test (DUT).

NOTE When using a four-terminal pair test fixture or test leads with a stopper, remove the stopper or the bumper of the E4980A.

CAUTION  Do not apply DC voltage or current to the UNKNOWN terminals. Applying DC voltage or current may lead to device failure. Connect the measurement sample (DUT) to the test port (or the test fixture, cables, etc. connected to the test port) after the LCR meter has been completely discharged.

The maximum load the UNKNOWN terminals can withstand is 10 kgf (nominal).

The test ports comply with Installation Category I of IEC 61010-1.

13. Front USB port

This port is used to save data in a USB memory. The USB indicator lights up while accessing the USB memory.

Connector types: Universal Serial Bus (USB) Jack, Type A (four contact points), Female.

Compliance Standards: USB 1.1

NOTE Do not connect any device other than a USB memory to the USB port. We do not support connections to the USB port of printers, devices with a built-in HDD, or USB hubs. To print a screen, refer to “To save a screenshot into USB memory” on page 191.

NOTE Do not unplug the USB memory while the USB indicator is on.

USB memory type

Use USB memory that is USB mass-storage-class compliant and formatted with FAT16 or FAT32. For points to notice, refer to “USB Memory Notes” on page 177.

Interface: USB 1.1

14. Ground terminal

Connected to the chassis of the E4980A. This is used for measurements that require guarding.

15. DC Source terminal

Outputs the DC source in the range from -10 V to 10 V. Option 001 is required for this function.

NOTE The DC source terminal is installed even in the E4980A without Option 001; however, the E4980A without Option 001 cannot use this terminal.

Rear Panel: Names and Functions of Parts

This section describes the names and functions of the parts on the E4980A's rear panel.

Figure 2-2

Rear panel

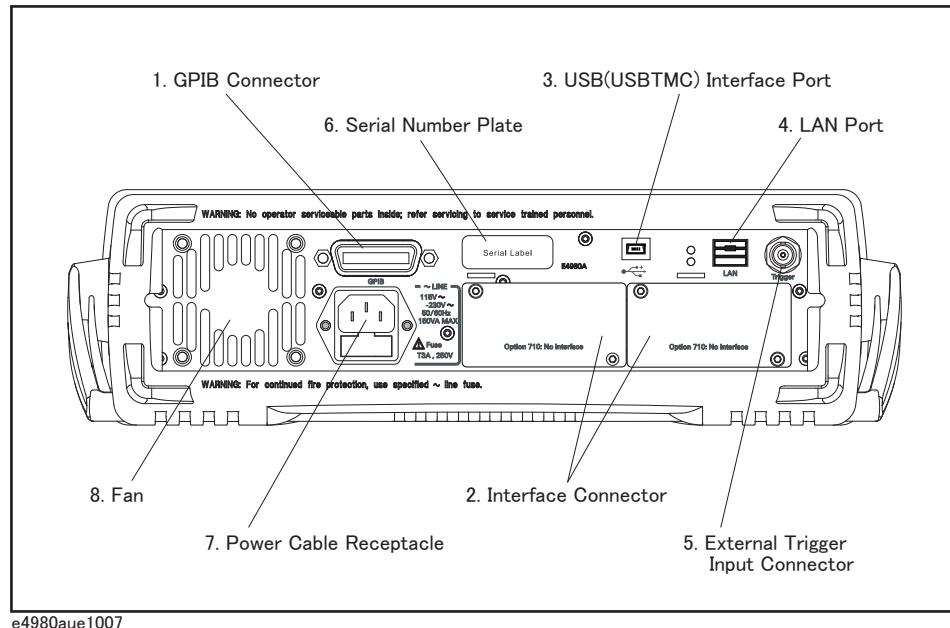

e4980aue1007

1. GPIB Interface Connector

General Purpose Interface Bus (GPIB). The connection of an external controller and other devices through this connector allows you to configure an automatic measurement system.

2. Interface Connector

If interface options are installed, the interface connectors will be installed as shown. If the E4980A is not equipped with an interface option, blank panels will cover this portion.

Interfaces with which the E4980A can be equipped as options are shown below.

Handler interface (Option E4980A-201)

This interface is for data exchange with an automatic machine (handler) used on a production line.

Connector type: 36-pin Centronics

Scanner interface (Option E4980A-301)

The interface to connect a scanner to perform up to 128 sets of multi-channel corrections and measurements.

Connector type: 14-pin Amphenol

Bias current interface (Option E4980A-002)

The interface to control the 42841A (Bias Current Source).

3. USB (USBTMC) Interface Port

Through this port, you can control the E4980A via external controllers.

Connector Types: Universal Serial Bus (USB) jack, type mini-B (five contact points), Female

Compliance Standards: USBTMC-USB488 and USB2.0

4. LAN Port

The port to connect the E4980A to a LAN (Local Area Network). Connecting this instrument to a LAN enables you to control this instrument by using SICL-LAN or telnet, or from an external PC via a Web server.

This is compliant with LXI standard (LAN eXtensions for Instrumentation): version 1.1 Class C.

Connector type: 8-pin RJ-45 connector

Compliance Standard: 10Base-T/100Base-TX Ethernet (automatic data rate selection)

NOTE

Auto-MDIX” function is effective on S/N MY4620XXX or later.

5. External Trigger Input Connector

The BNC connector to input the positive TTL pulse to trigger the E4980A with external trigger signals.(The trigger mode must be set to EXternal.)

6. Serial Number Plate

The seal showing the product’s serial number.

7. Power Cable Receptacle (to LINE)

The receptacle (outlet) to which the power cable is connected.

NOTE

To connect the device to a power source (outlet), use the supplied three-prong power cable with a ground conductor.

The plug attached to the power cable (on the power outlet side or device side of the cable) serves as the E4980A’s disconnecting device (device that cuts off the power supply). When the power supply must be cut off to avoid such danger as electric shock, pull out the power cable plug (on the power outlet side or device side of the cable). For the procedure for turning off the power in normal use, see the description in “1. Power switch” on page 40.

For more on the power supply, see “Verifying and Connecting the Power Cable” on page 27.

8. Fan

The cooling fan for controlling the temperature inside the E4980A. This fan extracts heated air from inside the LCR meter.

Screen Area: Names and Functions of Parts

This section describes the names and functions of parts on the E4980A's LCD screen.

Figure 2-3

Screen display

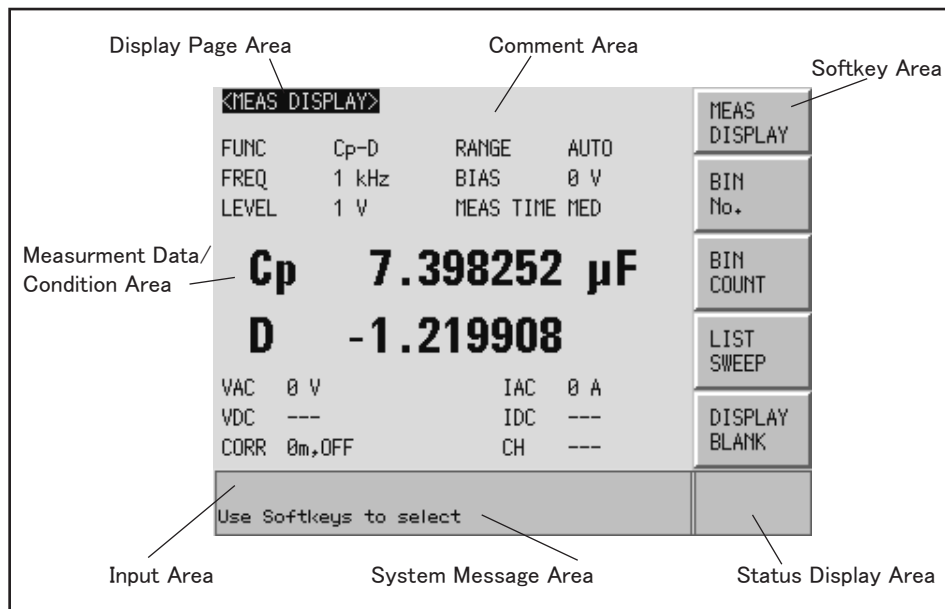

e4980aue1035

1. Display Page Area

Shows a display page name of the current display page. On each display page, three lines are collected together as one area.

2. Comment Line Area

You can input up to 30 characters in ASCII format by using the front panel or the DISPlay:LINE command of the GPIB command. The first 22 characters are displayed in this area.

This area is displayed on the following display pages.

- MEAS DISPLAY page
- BIN No. DISPLAY page
- BIN COUNT DISPLAY page
- LIST SWEEP DISPLAY page
- MEAS SETUP page

For the input method in the comment line, refer to "MEAS SETUP page" on page 91.

3. Softkey Area

Displays softkey labels corresponding to the field.

A ► displayed to the right of a softkey indicates that pressing that softkey will display the softkey label one level lower.

Pressing the **Return** key when the lower level softkey label is displayed will display the softkey label one level higher. In this case, a ◀ is displayed on the label to the left of the **Return** key.

Figure 2-4

Softkey Area

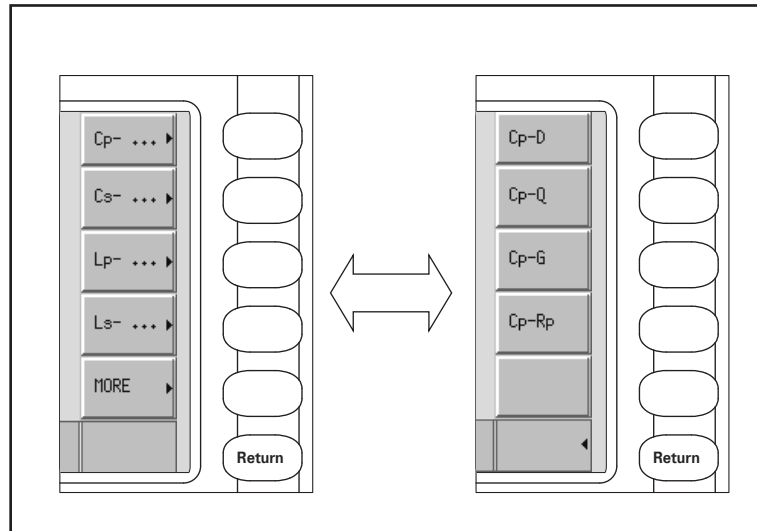

e4980auj1157

2. Overview

4. Measurement Data/Conditions Area

Displays measurement conditions and measurement results.

Under certain conditions one of the following messages may be displayed instead of the measurement results. For details, refer to “Displaying Errors instead of Measurement Results” on page 76.

Message	Description
OVERLOAD	This message is displayed when an overload occurs. For details, refer to “Displaying Errors instead of Measurement Results” on page 76.
---	This means that no measurement has been made or the data format will not hold the measurement results.
INFINITY	This message is displayed when a deviation mode of the deviation measurement function is % and measurement results cannot be calculated.

5. Input Line Area

Displays numeric values entered with the entry key.

6. System Message Area

Displays a system message, warning, and error message.

7. Status Display Area

Displays the status when DC bias or DC source is on, or any front panel key is locked. When sending SCPI commands from the external controller, “RMT” is displayed and the front panel keys are locked.

Basic Operation

The E4980A's basic operation is described below.

1. Display the desired page using both the MENU keys and softkeys.
2. Move the cursor to the desired field using the cursor keys. When the cursor is moved to a certain field, the field changes to an inverse video image of the original. The cursor can be moved from field to field (right and left or up and down).
3. The softkey labels corresponding to the field indicated by the cursor are displayed automatically. Press the desired softkey.

Use the entry keys to input numeric data. When one of the entry keys is pressed, the softkeys will change to the available unit softkeys. Pressing these unit softkeys terminates numeric input.

The unit changes according to the field selected.

How to Use Cursor Keys

Move the cursor to the desired field using the cursor keys as shown in Figure 2-5.

Figure 2-5 Cursor keys and a field operation example

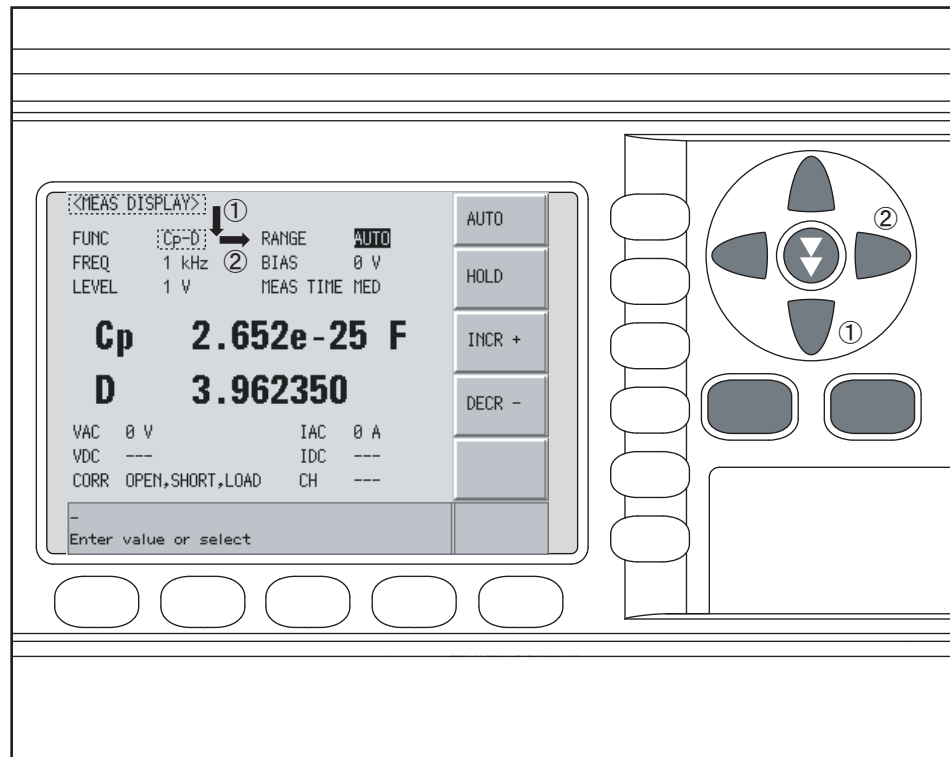

e4980auj1156

How to Use Skip Keys

The following describes how to use a skip key.

On a display page, three lines are collected together as one. By using a skip key, you can select the desired field quickly as the selected field moves from area to area.

Figure 2-6

Skip key and a field operation example

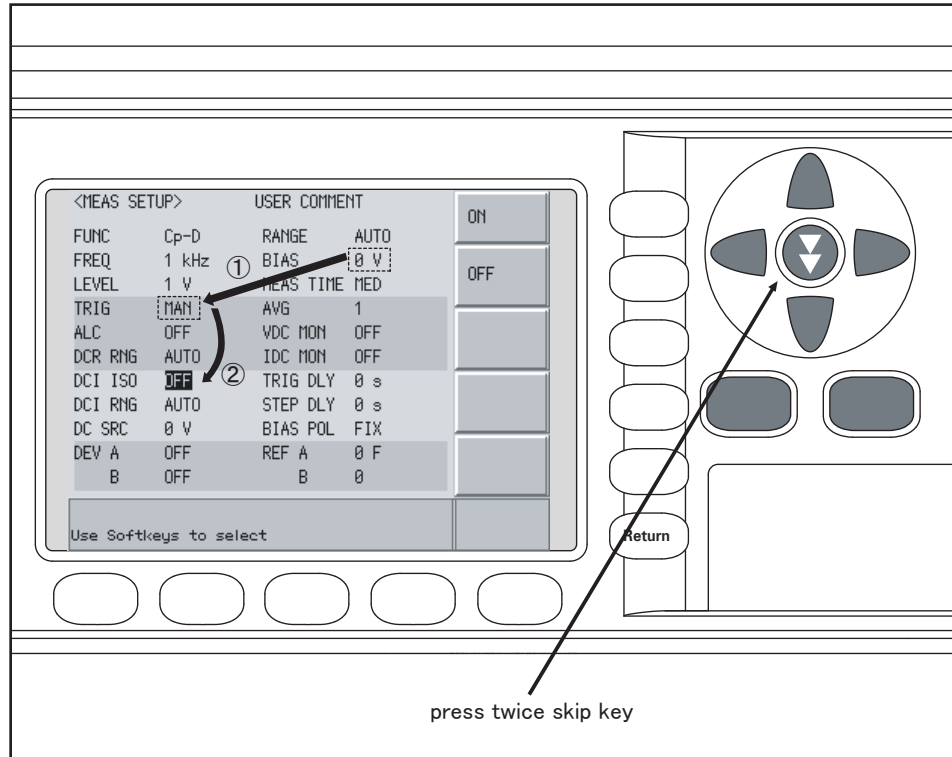

e4980aue1158

3 **Display Format**

This chapter describes each page of the DISPLAY FORMAT MENU of the E4980A.

MEAS DISPLAY Page

When you press the [DISPLAY FORMAT] key, the MEAS DISPLAY page appears. The following measurement controls can be set on this page (The field in parenthesis is used to set measurement controls).

- Measurement Function (FUNC)
- Impedance range (RANGE)
- Test Frequency (FREQ)
- Test Signal Level (LEVEL)
- DC Bias (BIAS)
- Measurement Time Mode (MEAS TIME)

Figure 3-1 shows the available fields and the softkeys that correspond to the fields on this page.

Figure 3-1 MEAS DISPLAY Page

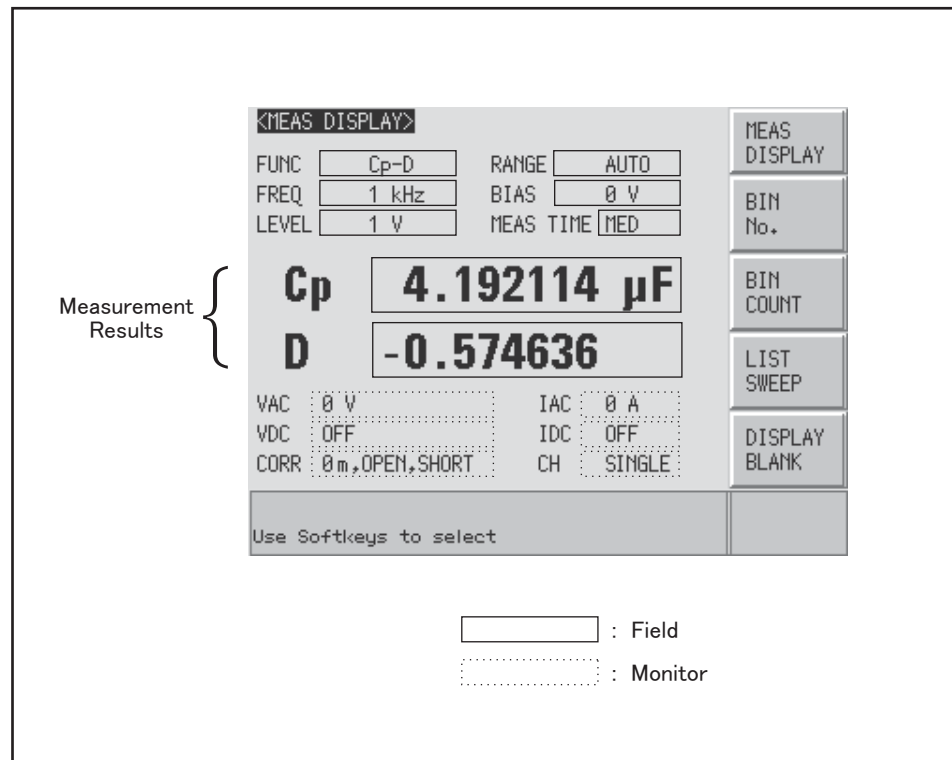

e4980aue1062

Pressing the [DISPLAY FORMAT] key when Figure 3-1 is displayed enlarges the measurement result as shown in Figure 5-2. Pressing the [DISPLAY FORMAT] key again returns to the display in Figure 3-1.

Figure 3-2

The enlarged MEAS DISPLAY for measurement results

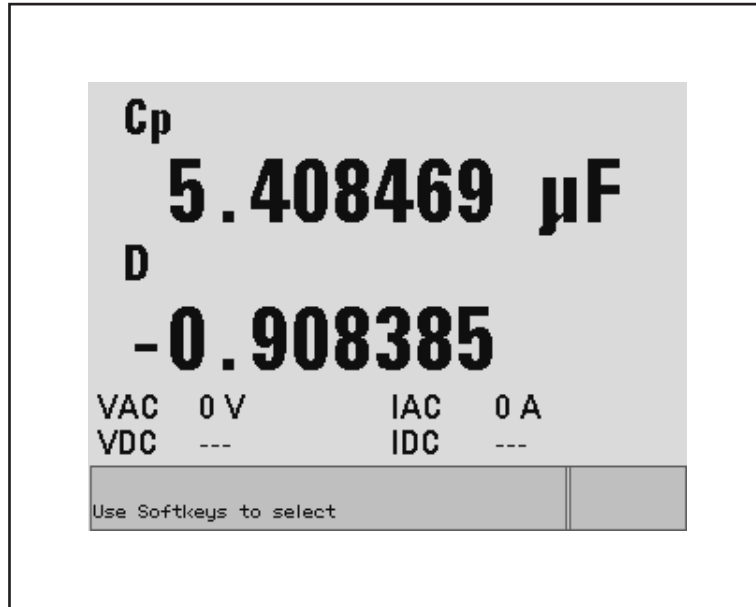

e4980auj1063

Measurement Function

The E4980A simultaneously measures two components of the complex impedance (parameters) in a measurement cycle.

Regardless of the types of measurement parameters, the test signal voltage (VAC) and the test signal current (IAC) are measured at the same time. When the E4980A is equipped with option 001, the DC bias voltage level (VDC) and the DC bias current level (IDC) are measured simultaneously.

NOTE

Regardless of the types of measurement parameters, the measurement result for the R-X parameter can be obtained using the SCPI command.

When the E4980A is equipped with option 001, DC resistance (Rdc), DC voltage (Vdc), and DC current (Idc) can be measured instead of impedance.

Types of measurement parameters

Types of measurement parameters are shown below.

Table 3-1

Measurement parameters

Primary parameter	Secondary parameter
Cp	D, Q, G, Rp
Cs	D, Q, Rs
Lp	D, Q, G, Rp, Rdc ^{*1}
Ls	D, Q, Rs, Rdc ^{*1}
R	X
Z	θ_d, θ_r
G	B
Y	θ_d, θ_r
Vdc ^{*1}	Idc ^{*1}

*1. This parameter can be set only when the E4980A is equipped with option 001.

NOTE

When the measurement parameter is DC voltage measurement/DC current measurement (Vdc-Idc), set the setting value of the test signal level (LEVEL field) to 0 V for accurate measurement.

Measurement parameter descriptions

The primary parameter measurement result is located on the upper line and the secondary parameter measurement result is on the lower line in Figure 3-1 on page 52.

Each parameter is described below.

Table 3-2

Primary parameter

Parameter	Description
Cp	Capacitance value measured using the parallel equivalent circuit model
Cs	Capacitance value measured using the series equivalent circuit model
Lp	Inductance value measured using the parallel equivalent circuit model
Ls	Inductance value measured using the series equivalent circuit model
R	Resistance
Z	Absolute value of impedance
G	Conductance
Y	Absolute value of admittance
Vdc ^{*1}	DC voltage

*1. This parameter can be set only when the E4980A is equipped with option 001.

Table 3-3

Secondary parameter

Parameter	Description
D	Dissipation factor
Q	Quality factor (inverse of dissipation factor)
G	Conductance
Rs	Equivalent series resistance measured using the series equivalent circuit model
Rp	Equivalent parallel resistance measured using the parallel equivalent circuit model
X	Reactance
B	Sustenance
θ	Phase angle
Idc ^{*1}	DC current
Rdc ^{*1}	DC resistance

*1. This parameter can be set only when the E4980A is equipped with option 001.

Equivalent parallel and serial combinations

The combinations of primary and secondary parameters, including the equivalent parallel and series combinations, are listed below.

Table 3-4

Measurement function

Primary parameter	Series mode	Parallel mode
Z	Z- θ_r Z- θ_d	-----
Y	-----	Y- θ_r Y- θ_d
C	Cs-D Cs-Q Cs-Rs	Cp-D Cp-Q Cp-G Cp-Rp
L	Ls-D Ls-Q Ls-Rs Ls-Rdc	Lp-D Lp-Q Lp-G Lp-Rp Lp-Rdc
R	R-X	-----
G	-----	G-B

Primary parameter	Secondary parameter
Vdc	Idc

NOTE Measurement function Vdc-Idc does not have the series mode and parallel mode.

Procedure for setting the measurement function

- Step 1.** Press the [Display Format] key.
- Step 2.** Press the **MEAS DISPLAY** softkey.
- Step 3.** Use the cursor keys to select the FUNC field.
- Step 4.** Use the softkeys to select the primary parameter.
- Step 5.** If the secondary parameter exists, select the secondary parameter from measurement parameters displayed using the softkeys.

NOTE For the combinations of measurement parameters, refer to Table 3-1 on page 54.

Impedance range

Impedance range mode

Two modes can be used to select the impedance range as shown in Table 3-5.

Table 3-5

Impedance range mode

Mode	Function overview	Advantage	Disadvantage
Auto range (auto selection)	The E4980A sets the optimum impedance range for the impedance of the DUT.	You do not need to select the impedance range.	The measurement time is longer due to the ranging time.
Hold range (manual selection)	Measurement is performed with a fixed impedance range regardless of the impedance of the DUT.	No ranging time is required.	You need to select a proper range depending on the value of the DUT.

Available impedance range

The hold range has nine impedance ranges, but when option 001 is installed, it has ten. The impedance range is selected according to the DUT's impedance even if the measurement parameter is capacitance or inductance.

Model	Impedance range (Ω)
Standard	1, 10, 100, 300, 1 k, 3 k, 10 k, 30 k, 100k
Option 001	100 m ^{*1} , 1, 10, 100, 300, 1 k, 3k, 10 k, 30 k, 100k

*1. This cannot be used when the test signal level is less than or equal to 2 V.

Effective measurement range for each impedance range for impedance measurement

Figure 3-3 shows the range that can be displayed and the effective measuring range for each impedance range while in the impedance mode ($|Z|$, R, X). For example, 50-k Ω DUT impedance can be measured using the ranges of 100 k Ω to 30 k Ω , but the E4980A's accuracy specification is only met when using the 30-k Ω range. If this DUT is measured with the 100-k Ω range, "OVERLOAD" will be displayed.

Figure 3-3

Effective measurement range for each impedance range (Impedance measurement)

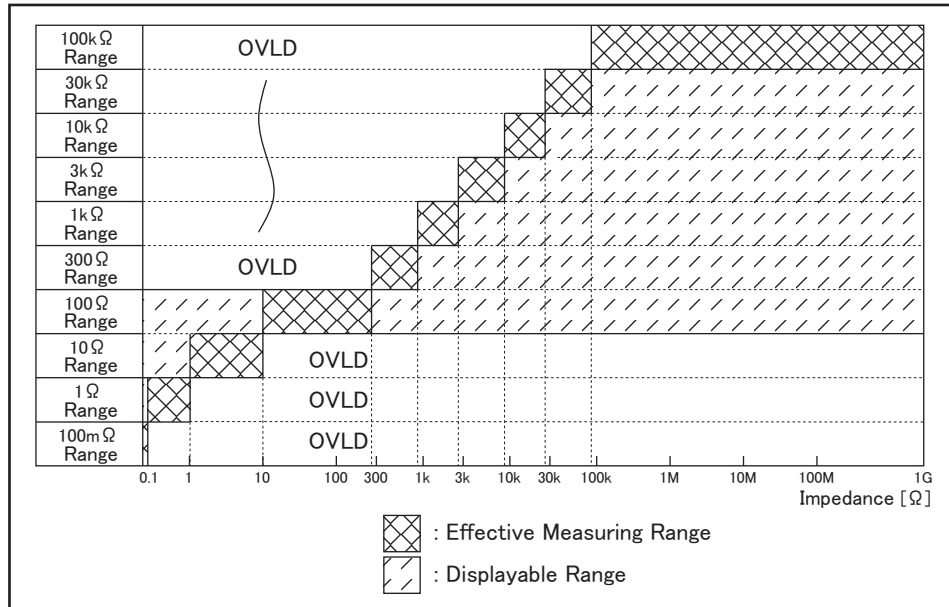

e4980aue1014

Table 3-6

Effective measurement range for the impedance range when it is in the HOLD state for impedance measurement

Impedance range (Ω)	Effective measurement range
100 m ^{*1}	0 < Impedance \leq 108 m
1	108 m ^{*2} < Impedance \leq 1.08
10	1.08 < Impedance \leq 10.08
100	10.08 < Impedance < 276
300	276 \leq Impedance < 0.92 k
1 k	0.92 k \leq Impedance < 2.76 k
3 k	2.76 k \leq Impedance < 9.2 k
10 k	9.2 k \leq Impedance < 27.6 k ^{*3}
30 k	27.6 k \leq Impedance < 92 k ^{*4}
100 k	92 k \leq Impedance

*1. This can be set when the test signal level is more than 2 V.

- *2. When the test signal level is less than or equal to 2 V or 20 mA, it is 0 (zero).
- *3. When test frequency is more than 100 kHz and the test signal level is less than or equal to 0.2 V (2 mA), it is more than 9.2 k.
- *4. When test frequency is more than 100 kHz and the test signal level is more than 0.2 V and less than or equal to 2 V (more than 2 mA and less than or equal to 20 mA), it is more than 27.6 k.

Effective measurement range for each impedance range

The following shows the effective measurement range of each impedance range, in which the E4980A's measurement accuracy meets its specifications.

When the impedance range is set manually, the optimum impedance range should be selected by matching the impedance of the DUT to the effective measurement range shown in Figure 3-4, Figure 3-5, and Figure 3-6. When the impedance range is set to AUTO, the optimum impedance range is automatically selected according to the impedance of each DUT.

NOTE

The impedance range is limited by the test frequency setting when the test signal level is less than or equal to 2 V. When the impedance range and test frequency are set under the above conditions, the test frequency must be set first, followed by the impedance range. If you set the impedance range first and then frequency, the resulting impedance range may not be the one you wanted to set.

Figure 3-4 Effective measurement range (0.2 V or $2 \text{ mA} < \text{Test signal level} \leq 2 \text{ V}$ or 20 mA)

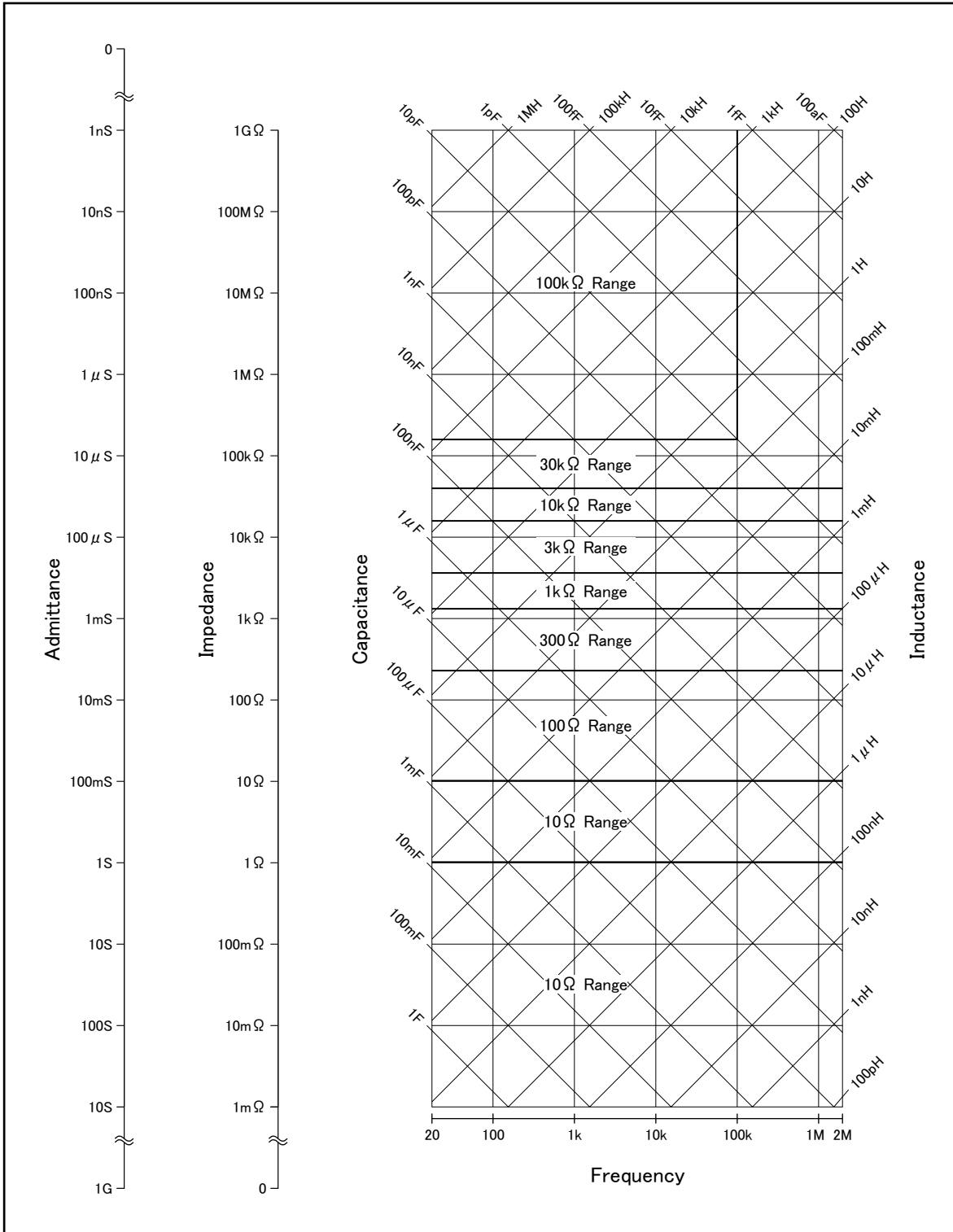

e4980aue1015

Figure 3-5 Effective measurement range (Test signal level > 2 V or 20 mA)

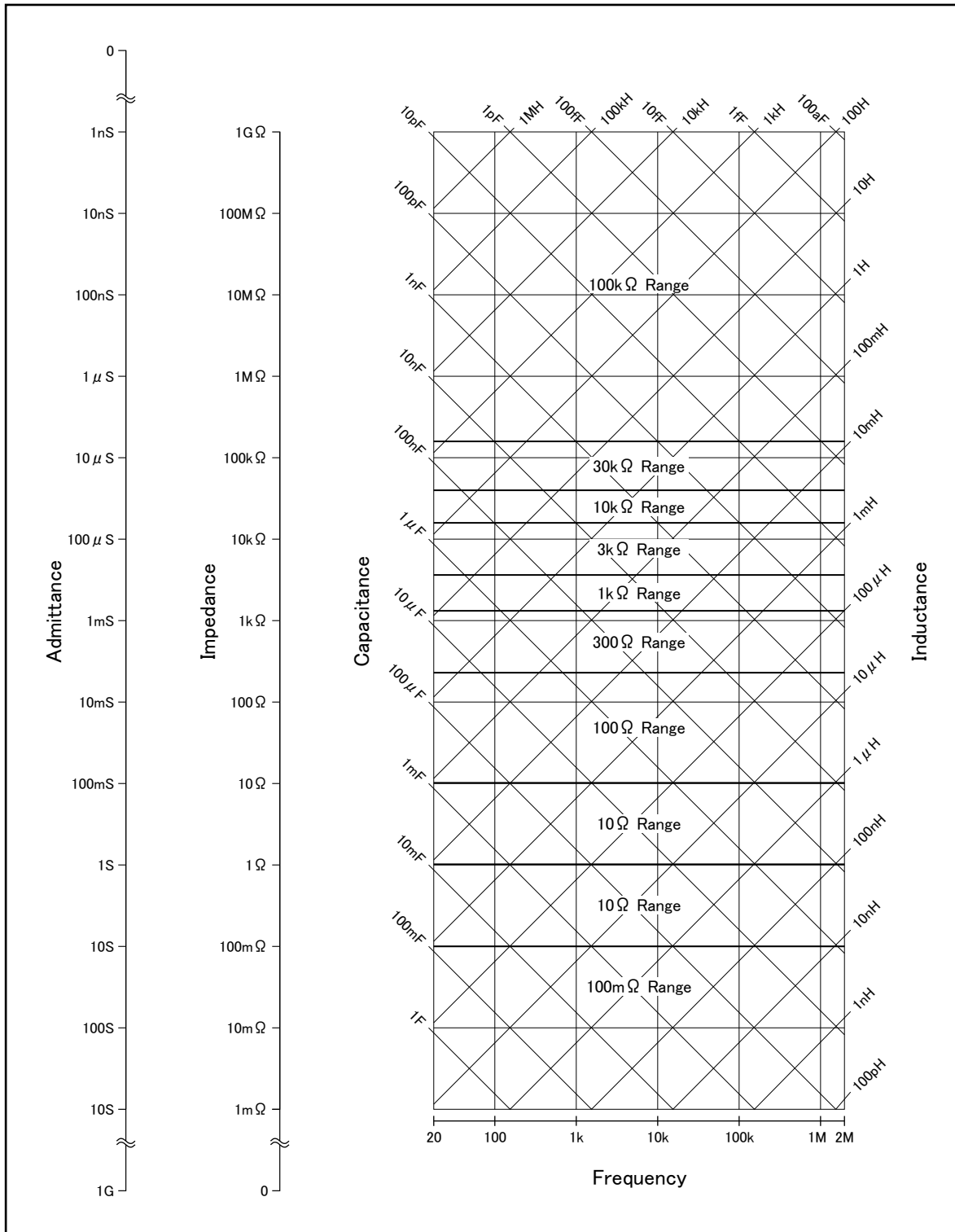

e4980aue1016

3. Display Format

Figure 3-6 Effective measurement range (Test signal level ≤ 0.2 V or 2 mA)

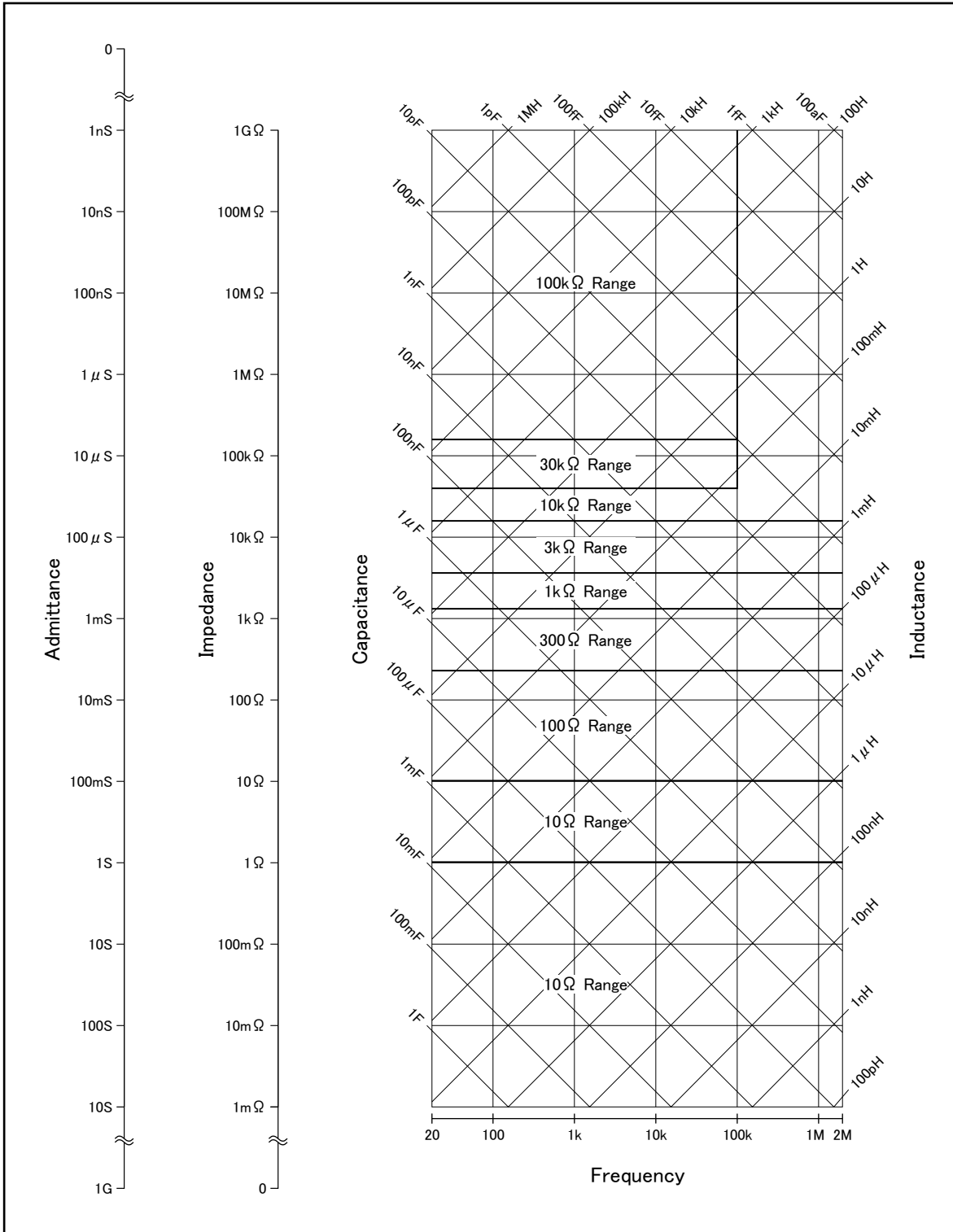

e4980aue1165

Procedure for setting the impedance range

- Step 1.** Press the [Display Format] key.
- Step 2.** Press the **MEAS DISPLAY** softkey.
- Step 3.** Use the cursor keys to select the RANGE field.
- Step 4.** Use the softkeys to select the impedance range mode or impedance range.

Softkey	Function
AUTO	Sets the impedance range mode to AUTO.
HOLD	Sets the impedance range mode to HOLD.
INCR +	Increments the impedance range in the HOLD mode.
DECR -	Decrements the impedance range in the HOLD mode.

Manually setting the time for the impedance range mode

Changing impedance range requires a few milliseconds to several tens of milliseconds. For details, refer to “Settling time” on page 436 in Chapter 11, “Specifications and Supplemental Information.”

Test Frequency

Test frequency point

The E4980A's test frequency can be set in the range from 20 Hz to 2 MHz. The last digit of the four-digit test frequency display (including digits after the decimal point) can be set as the resolution.

Table 3-7 shows the test frequency point of each frequency range (F).

Table 3-7

Frequency range and test frequency point

Frequency range (F)	Test frequency point	Resolution
$20 \text{ Hz} \leq F \leq 99.99 \text{ Hz}$	20.00 Hz, 20.01 Hz...99.99 Hz	0.01 Hz
$100 \text{ Hz} \leq F \leq 999.9 \text{ Hz}$	100.0 Hz, 100.1 Hz...999.9 Hz	0.1 Hz
$1 \text{ kHz} \leq F \leq 9.999 \text{ kHz}$	1.000 kHz, 1.001 kHz...9.999 kHz	1 Hz
$10 \text{ kHz} \leq F \leq 99.99 \text{ kHz}$	10.00 kHz, 10.01 kHz...99.99 kHz	10 Hz
$100 \text{ kHz} \leq F \leq 999.9 \text{ kHz}$	100.0 kHz, 100.1 kHz...999.9 kHz	100 Hz
$1 \text{ MHz} \leq F \leq 2 \text{ MHz}$	1.000 MHz, 1.001 MHz...2.000 MHz	1 kHz

NOTE

When more than five-digit numeric data (including digits after the decimal point) are entered, the nearest test frequency point is automatically set.

Procedure for setting test frequency

- Step 1.** Press the [Display Format] key.
- Step 2.** Use the cursor keys to select the FREQ field.
- Step 3.** Use the softkeys or numeric entry keys to enter the test frequency. When data is entered with the numeric entry keys, the softkeys change to unit labels (Hz, kHz, MHz).

Softkey	Function
INCR ++	Increments the test frequency to the next sequentially higher tenfold value after 20 Hz. Refer to Table 3-8 for the test frequency points that can be set using this softkey.
INCR +	Increments the current test frequency to the next sequentially higher frequency point. There are ten frequency points between successive decade values. Refer to Table 3-9 for the sequential frequency points that can be set using this softkey.
DECR -	Decreases the test frequency to the next sequentially lower frequency point. There are ten frequency points between successive decade values. Refer to Table 3-9 for the frequency points that can be set using this softkey.

Softkey	Function
DECR --	Decreases the test frequency to the next sequentially lower tenth value after 20 Hz. Refer to Table 3-8 for the frequency points that can be set using this softkey.

Table 3-8 Test frequency that can be set using INCR ++ / DECR --

INCR ++ / DECR --

20 Hz
100 Hz
1 kHz
10 kHz
100 kHz
1 MHz
2 MHz

Table 3-9 Test frequency that can be set using INCR + / DECR -

INCR + / DECR -

20 Hz	100 Hz	1 kHz	10 kHz	100 kHz	1 MHz
25 Hz	120 Hz	1.2 kHz	12 kHz	120 kHz	1.2 MHz
30 Hz	150 Hz	1.5 kHz	15 kHz	150 kHz	1.5 MHz
40 Hz	200 Hz	2 kHz	20 kHz	200 kHz	2 MHz
50 Hz	250 Hz	2.5 kHz	25 kHz	250 kHz	
60 Hz	300 Hz	3 kHz	30 kHz	300 kHz	
80 Hz	400 Hz	4 kHz	40 kHz	400 kHz	
	500 Hz	5 kHz	50 kHz	500 kHz	
	600 Hz	6 kHz	60 kHz	600 kHz	
	800 Hz	8 kHz	80 kHz	800 kHz	

Time required for setting the test frequency

Changing the test frequency requires a few milliseconds to several tens of milliseconds. For details, refer to “Settling time” on page 436 of Chapter 11, “Specifications and Supplemental Information.”

Test Signal Level

The E4980A's test signal level can be set as the effective value (RMS value) of a sine wave of the test frequency from the unit's internal oscillator. You can set either the oscillator voltage level or the oscillator current level. The output impedance is 100 Ω .

NOTE

The set value of the oscillator current level is the value set when the measurement contacts (UNKNOWN terminals) are shorted together.

The set value of the oscillator voltage level is the value set when the measurement contacts (UNKNOWN terminals) are opened.

The E4980A can measure a device using a constant voltage or current level by using the automatic level control function. (The automatic level control function (ALC field) can be set to ON from the MEAS SETUP page.) When a constant voltage or current level measurement is performed, an asterisk mark (*) appears at the end of the LEVEL display. For more information about the automatic level control function, refer to "Automatic level control" on page 96.

Test signal level and resolution (Standard)

When option 001 (power/DC bias enhance) is not installed, the oscillator voltage level can be set with a resolution listed in Table 3-10, or the oscillator current level can be set with a resolution listed in Table 3-11.

Table 3-10

Oscillator voltage level and resolution (Std.)

Oscillator voltage level	Resolution
0 Vrms to 200 mVrms	100 μ Vrms
200 mVrms to 500 mVrms	200 μ Vrms
500 mVrms to 1 Vrms	500 μ Vrms
1 Vrms to 2 Vrms	1 mVrms

Table 3-11

Oscillator current level and resolution (Std.)

Oscillator current level	Resolution
0 Arms to 2 mArms	1 μ Arms
2 mArms to 5 mArms	2 μ Arms
5 mArms to 10 mArms	5 μ Arms
10 mArms to 20 mArms	10 μ Arms

Test signal level and resolution (Option 001)

When option 001 (power/DC bias enhance) is installed, the oscillator voltage level can be set with a resolution listed in Table 3-12, or the oscillator current level can be set with a resolution listed in Table 3-13.

Table 3-12

Oscillator voltage level and resolution (Option 001)

Oscillator voltage level	Resolution
0 Vrms to 200 mVrms	100 μ Vrms
200 mVrms to 500 mVrms	200 μ Vrms
500 mVrms to 1 Vrms	500 μ Vrms
1 Vrms to 2 Vrms	1 mVrms
2 Vrms to 5 Vrms	2 mVrms
5 Vrms to 10 Vrms	5 mVrms
10 Vrms to 20 Vrms*1	10 mVrms

*1. When the test frequency is more than 1 MHz, the maximum oscillator voltage level that can be set is 15 Vrms.

Table 3-13

Oscillator current level and resolution (Option 001)

Oscillator current level	Resolution
0 Arms to 2 mArms	1 μ Arms
2 mArms to 5 mArms	2 μ Arms
5 mArms to 10 mArms	5 μ Arms
10 mArms to 20 mArms	10 μ Arms
20 mArms to 50 mArms	20 μ Arms
50 mArms to 100 mArms	50 μ Arms

Test signal level setting procedure

- Step 1.** Press the [Display Format] key
- Step 2.** Press the **MEAS DISPLAY** softkey.
- Step 3.** Use the cursor keys to select the LEVEL field.
- Step 4.** Use the softkeys or numeric entry keys to enter the test signal level. When data is entered with the numeric entry keys, the softkeys change to units labels (mV, V, μ A, mA, A).

Softkey	Function
INCR ++	Increases the oscillator's output level with a resolution shown in Table 3-14 or Table 3-15.

3. Display Format

Softkey	Function
INCR +	Increases the oscillator's output level with a resolution shown in Table 3-10 to Table 3-13.
DECR -	Decreases the oscillator's output level with a resolution shown in Table 3-10 to Table 3-13.
DECR --	Decreases the oscillator's output level with a resolution shown in Table 3-14 or Table 3-15.

Table 3-14 Oscillator's voltage level that can be set with INCR ++ / DECR --

INCR ++ / DECR -- (Vrms)
0,
1 m, 2 m, 3 m, •••, 9 m
10 m, 20 m, 30 m, •••, 90 m
100 m, 200 m, 300 m, •••, 900 m
1, 2, 3, •••, 9 ^{*1}
10, 20 ^{*1}

*1. The voltage level can be set to more than 2 V only when option 001 is installed.

Table 3-15 Oscillator's current level that can be set with INCR ++ / DECR --

INCR ++ / DECR -- (Arms)
0,
10 μ, 20 μ, 30 μ, •••, 90 μ
100 μ, 200 μ, 300 μ, •••, 900 μ
1 m, 2 m, 3 m, •••, 9 m
10 m, 20 m, 30 m, •••, 90 m ^{*1}
100 m ^{*1}

*1. The current level can be set to more than 20 m only when option 001 is installed.

DC Bias

The E4980A has an internal DC bias. A DC bias is output when the DC Bias key on the front panel is set to ON.

The DC Bias key is a toggle-type switch used to enable DC bias output. When you press the DC Bias key, **DCBIAS** appears in the status display area and the LED indicator for DC bias is ON (orange). When you press the DC Bias key again, **DCBIAS** disappears from the status display area and the LED indicator is OFF. If the DC Bias key is set to OFF, the setting value for the DC bias is not output even though the DC bias is set to ON in the BIAS field.

The setting value of the DC bias signal voltage is the value set when the measurement contacts (UNKNOWN terminals) are opened.

The setting value of the DC bias signal current is the value set when the measurement contacts (UNKNOWN terminals) are shorted.

The range of the DC bias has two types: AUTO and FIX. When the E4980A is initiated or preset, AUTO is set. The following descriptions are effective when AUTO is set as a range. Use the SCPI command to fix the range. For details, refer to “:BIAS:RANGe:AUTO” on page 289.

DC bias (Standard)

When option 001 (power/DC bias enhance) is not installed, the DC bias can be set with a resolution listed in Table 3-16. The level of the DC bias signal current cannot be set without option 001 present.

Table 3-16

DC bias and resolution (Std.)

DC bias signal voltage	DC bias signal current
0 V, 1.5 V, 2.0 V	unavailable

DC bias and resolution (Option 001)

When option 001 (power/DC bias enhance) is installed, the DC bias signal voltage and signal current can be set with a resolution listed in Table 3-17 or Table 3-18.

Table 3-17

DC bias and resolution (Option 001)

DC bias signal voltage level	Resolution
± (0 V to 5 V)	100 μV *1
± (5 V to 10 V)	1 mV
± (10 V to 20 V)	2 mV
± (20 V to 40 V)	5 mV

*1. Effective resolution is 330 μV .

Table 3-18

DC bias and resolution (Option 001)

DC bias signal current level	Resolution
± (0A to 50 mA)	1 μA *1
± (50 mA to 100 mA)	10 μA

*1. Effective resolution is 3.3 μA .

When a DUT is connected to the measurement contacts, the setting current value is different from the actual current passing through the DUT. For normal measurement taken by applying the signal current through a device, refer to “DC Bias Current Isolation” on page 100.

Figure 3-7

DC bias signal current

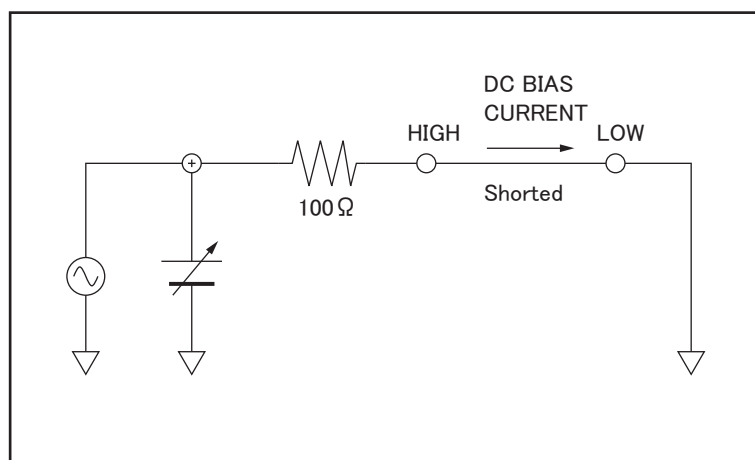

e4980aue1017

Setting limits for DC bias and test signal level

When both the DC bias and the test signal level are set under the following conditions, the amount of DC bias plus the test signal level is limited to the values listed in Table 3-19

- Option 001 is installed.
- The DC Bias key on the front panel is set to ON.

Table 3-19 DC bias and test signal level-setting limits

Setting value		Limit
DC bias	Test signal level	
Vdc (V)	Vosc (Vrms)	$V_{osc} \times \sqrt{2} \times 1.15 + V_{dc} \times 1.002 < 42 \text{ V}$
Vdc (V)	Iosc (Arms)	$I_{osc} \times \sqrt{2} \times 115 + V_{dc} \times 1.002 < 42 \text{ V}$
Idc (A)	Vosc(Vrms)	$V_{osc} \times \sqrt{2} \times 1.15 + I_{dc} \times 100.2 < 42 \text{ V}$
Idc (A)	Iosc (Arms)	$I_{osc} \times \sqrt{2} \times 115 + I_{dc} \times 100.2 < 42 \text{ V}$

Procedure for setting DC bias

- Step 1.** Press the [Display Format] key.
- Step 2.** Press the **MEAS DISPLAY** softkey.
- Step 3.** Use the cursor keys to select the BIAS field.
- Step 4.** Use the softkeys or numeric entry keys to enter the test signal level. When data is entered with the numeric entry keys, the softkey labels are changed to the appropriate unit labels (mV, V, uA, mA, A).

Softkey	Function
INCR ++	Increases the oscillator's output level with a resolution shown in Table 3-20 or Table 3-21.
INCR +	Increases the oscillator's output level with a resolution shown in Table 3-16 to Table 3-18.
DECR -	Decreases the oscillator's output level with a resolution shown in Table 3-16 to Table 3-18.
DECR --	Decreases the oscillator's output level with a resolution shown in Table 3-20 or Table 3-21.

Table 3-20

DC bias signal voltage that can be set with INCR ++ / DECR --

INCR ++ / DECR -- (V) *1
0,
±100 μ, ±200 μ, ±300 μ, •••, ±900 μ
±1 m, ±2 m, ±3 m, •••, ±9 m
±10 m, ±20 m, ±30 m, •••, ±90 m
±100 m, ±200 m, ±300 m, •••, ±900 m
±1, ±2, ±3, •••, ±9
±10, ±20, ±30, ±40

*1. When option 001 is not installed, only 0 V, 1.5 V, and 2.0 V can be set.

Table 3-21

DC bias signal current that can be set with INCR ++ / DECR --

INCR ++ / DECR -- (A) *1
0,
±1 μ, ±2 μ, ±3 μ, •••, ±9 μ
±10 μ, ±20 μ, ±30 μ, •••, ±90 μ
±100 μ, ±200 μ, ±300 μ, •••, ±900 μ

Table 3-21

DC bias signal current that can be set with INCR ++ / DECR

<p>INCR ++ / DECR -- (A)*1</p> <p>±1 m, ±2 m, ±3 m, •••, ±9 m</p> <p>±10 m, ±20 m, ±30 m, •••, ±90 m</p> <p>±100 m</p>

*1. This cannot be set when option 001 is not installed.

Step 5. Press [DC Bias] to set the DC bias output to ON. **DCBIAS** appears in the status display area and the LED indicator for DC bias lights up in orange.

Settling time for the DC bias signal voltage

Changing the DC bias requires a few milliseconds to several tens of milliseconds. For details, refer to “DC bias settling time” on page 445 of Chapter 11, “Specifications and Supplemental Information.”

Measurement Time Mode

Three measurement time modes (SHORT, MEDIUM, LONG) can be selected for the E4980A. A longer measurement time will result in more stable and accurate measurement results. Refer to “Measurement time” on page 437 For details on the measurement time of each measurement time mode.

Procedure for setting measurement time mode

- Step 1.** Press the [Display Format] key.
- Step 2.** Press the **MEAS DISPLAY** softkey.
- Step 3.** Use the cursor keys to select the MEAS TIME field.
- Step 4.** Use the softkeys to set the measurement time.

Softkey	Function
SHORT	Shortens the measurement time
MED	Sets the measurement time between SHORT and LONG
LONG	Lengthens the measurement time

Display Setting for Measurement Results

The E4980A can set the display digits and display units for measurement results (primary parameter/secondary parameter). For measurement parameters whose “setting available?” column is No in Table 3-22, the display setting cannot be changed. For measurement parameters whose display digit can be set to AUTO or FIXED, generally AUTO is selected. Regarding the display range for measurement values, refer to “Measurement display ranges” on page 404 of Chapter 11, “Specifications and Supplemental Information.”

Table 3-22 shows the digits and units that can be set for each measurement parameter.

Under certain conditions, a message will be displayed instead of measurement results. For details, refer to “Displaying Errors instead of Measurement Results” on page 76

Table 3-22 Display Settings for Measurement Results

Measurement Parameter	Unit	Setting available?	Display digits	Supplementary unit	Minimum display	Maximum display
Vdc	V	Yes	AUTO/FIX	a,f,p,n,u,m,k,M,G,T,P,E	±1.000000a	±999.9999E
Idc	A	Yes	AUTO/FIX	a,f,p,n,u,m,k,M,G,T,P,E	±1.000000a	±999.9999E
R,X,Z,Rdc	Ω	Yes	AUTO/FIX	a,f,p,n,u,m,k,M,G,T,P,E	±1.000000a	±999.9999E
G,B,Y	S	Yes	AUTO/FIX	a,f,p,n,u,m,k,M,G,T,P,E	±1.000000a	±999.9999E
Cp,Cs	F	Yes	AUTO/FIX	a,f,p,n,u,m,k,M,G,T,P,E	±1.000000a	±999.9999E
Lp,Ls	H	Yes	AUTO/FIX	a,f,p,n,u,m,k,M,G,T,P,E	±1.000000a	999.9999E
θ-rad	rad	Yes	AUTO/FIX	a,f,p,n,u,m,k,M,G,T,P,E	±1.000000a	±3.141593
D	n.a.	No	FIX	n.a.	±0.000001	±9.999999
Q	n.a.	No	FIX	n.a.	±0.01	±99999.99
θ-deg	deg	No	FIX	n.a.	±0.0001	±180.0000
%	%	No	FIX	n.a.	±0.0001	±999.9999

Procedure to change display setting

- Step 1.** Press the [Display Format] key.
- Step 2.** Press the **MEAS DISPLAY** softkey.
- Step 3.** Use the cursor keys to select the field in which a measurement result of primary parameter or secondary parameter is displayed.
- Step 4.** Use the following softkeys to set the display.

Softkey	Function
D.P. AUTO	Automatically displays the appropriate digits and units
D.P. FIX	Displays measurement data using a fixed-point display format. In this case, ▲ is displayed at the fixed decimal point. (refer to Figure 3-8).
D.P. POS INCR +	Moves the decimal point to the left. Supplementary units are also changed.
D.P. POS DECL -	Moves the decimal point to the right. Supplementary units are also changed.

Figure 3-8

Fixed-display sample of a measurement result

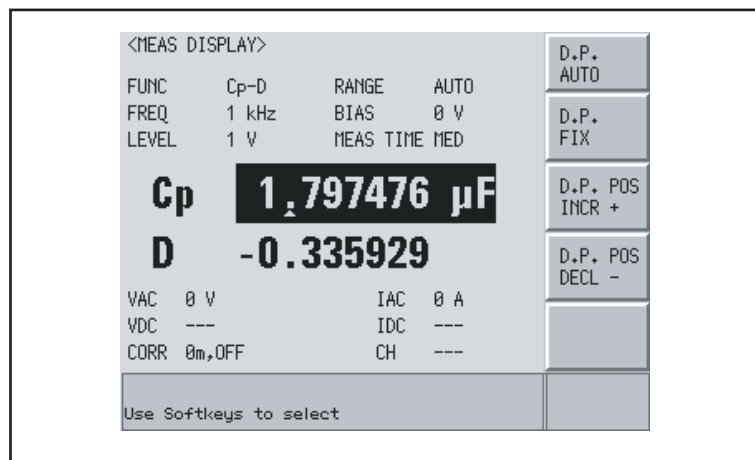

e4980auj1161

Displaying Errors instead of Measurement Results

Under certain conditions, the following message will appear instead of the measurement results. A description of each message is provided below.

Error messages

Message	Description
OVERLOAD	This message appears when overload occurs. The returned value is “9.9E37” when using the SCPI command. Conditions in which overload occurs differ depending on the impedance range settings. For details, refer to Table 3-26 on page 78.
---	This appears when no measurement was performed, or the measurement result is beyond the display range.
INFINITY	This message appears when the deviation mode of the deviation measurement function is % and the measurement result cannot be calculated.

Conditions where overload occurs for impedance measurement

Conditions differ depending on the impedance range setting (RANGE field).

Impedance range	Conditions
AUTO	<ul style="list-style-type: none"> E4980A’s internal detector detects overload When the DUT’s distortion is large When the DUT’s response is slow
HOLD	Conditions differ depending on the impedance range. Refer to Table 3-23

Table 3-23

Overload range when the impedance range is in the HOLD state for impedance measurement

Impedance range (Ω) (RANGE field)	Measurable range	Range in which overload occurs
0.1	0 to 0.11	more than 0.11
1	0 to 1.1	more than 1.1
10	0 to 11	more than 11
100	0 or more	n.a.
300	270 or more	less than 270
1 k	900 or more	less than 900
3 k	2700 or more	less than 2700

Table 3-23

Overload range when the impedance range is in the HOLD state for impedance measurement

Impedance range (Ω) (RANGE field)	Measurable range	Range in which overload occurs
10 k	9,000 or more	less than 9,000
30 k	27,000 or more	less than 27,000
100 k	90,000 or more	less than 90,000

Conditions where overload occurs for DCR measurement

Conditions differ depending on the DCR impedance-range setting (DCR RNG field).

Impedance range	Conditions
AUTO	When the E4980A's internal detector detects overload
HOLD	Conditions differ depending on the impedance range. Refer to Table 3-24

Table 3-24

Overload range when the impedance range is in the HOLD state for DCR measurement

Impedance range (Ω) (DCR RNG field)	Measurable range	Range in which overload occurs
10	0 to 11	more than 11
100	0 or more	n.a.
1 k	900 or more	less than 900
10 k	9,000 or more	less than 9,000
100 k	90,000 or more	less than 90,000

Conditions in which overload occurs for Vdc-Idc measurement (DC source-level monitor)

Conditions differ depending on the Idc impedance range setting (DCI RNG field).

Impedance range	Conditions
AUTO	<ul style="list-style-type: none"> When the measurement value exceeds 125 mA When the E4980A's internal detector detects overload
HOLD	Conditions differ depending on the impedance range. Refer to Table 3-25

3. Display Format

NOTE Overload does not occur for Vdc measurement.

Table 3-25 Overload range when the impedance range is in the HOLD state for Idc measurement

Impedance range (A) (DCI RNG field)	Measurable range	Range inn which overload occurs
20 μ	0 to 22 μ	more than 22 μ
200 μ	0 to 220 μ	more than 220 μ
2 m	0 to 2.2 m	more than 2.2 m
20 m	0 to 22 m	more than 22 m
100 m	0 to 110 m	more than 110 m

List of measurement results when overload occurs.

This section describes measurement results and each monitor value when overload occurs.

The bold font in the list indicates the measurement parameter for which overload occurs.

“*” indicates that measurement results, judgement, and BIN count are normal.

Table 3-26 List of measurement results when overload occurs

Measurement parameter	Meas. value (primary)	Meas. value (secondary)	VAC/IAC monitor	VDC monitor	IDC monitor	IN/OUT	BIN No.
Impedance measurement (except for Ls/Lp-Rdc)	OVLD	OVLD	---	---	---	L	OUT
Impedance measurement (except for Ls/Lp-Rdc)	OVLD	OVLD	---	---	---	L	OUT
Impedance measurement (Ls/Lp-Rdc)	OVLD	---	---	---	---	L	OUT
DCR measurement (Ls/Lp-Rdc)	*	OVLD	*	*	*	L	OUT
Vdc-Idc measurement	*	OVLD	0	*	OVLD	L	OUT
Other than Vdc-Idc measurement	*	*	*	OVLD	---	*	*
Other than Vdc-Idc measurement	*	*	*	*	OVLD	*	*

NOTE OVLD is displayed as OVERLOAD on the display.

Monitor Information

The following describes monitor information displayed on the MEAS DISPLAY page. This information cannot be changed on the MEAS DISPLAY page.

Monitor information	Description
VAC	Displays the test signal voltage level (AC voltage). Displays measurement results regardless of the type of measurement parameter
IAC	Displays the test signal current level (AC current). Displays measurement results regardless of the type of measurement parameter
VDC	Displays the DC bias voltage level (DC voltage). Set the VDC MON field of the [Means Setup] page to ON when you want to display it.* ¹
IDC	Displays the DC bias current level (DC current). Set the IDC MON field of the [Means Setup] page to ON when you want to display it
CORR	Displays the correction information of enabled correction types (OPEN/SHORT/LOAD) and cable length
CH	Displays the channel number in the multi-correction mode* ²

*1. This can be displayed only when option 001 is installed.

*2. SINGLE is displayed when option 301 is not installed.

NOTE

The VDC/IDC monitor values are the ones measured under the condition that the setting value of the test signal level (LEVEL field) is output. Therefore, these values are different from the measurement results displayed when the measurement parameter is DC voltage measurement/DC current measurement (Vdc-Idc).

BIN NO. DISPLAY Page

When you press the [Display Format] key and **BIN No.** soft key, the BIN No. DISPLAY page appears. The bin sorting results are displayed in large characters while the measurement results are shown in normal characters. The following measurement controls can be set from the BIN No. DISPLAY page (The field in parenthesis is used when this control is set).

- Comparator function ON/OFF (COMP field)

This page also provides the following information in the monitor areas (each monitor area looks like a field but is not). These conditions can be set from the MEAS SETUP page and the CORRECTION page, and most conditions can be set from the MEAS DISPLAY page.

- Measurement Function (FUNC)
- Impedance range (RANGE)
- Test Frequency (FREQ)
- Test Signal Level (LEVEL)
- DC Bias (BIAS)
- Measurement Time Mode (MEAS TIME)
- Correction Information (CORR)

Figure 3-9 shows the available fields and the softkeys that correspond to each field on this page.

Figure 3-9

BIN NO. DISPLAY page

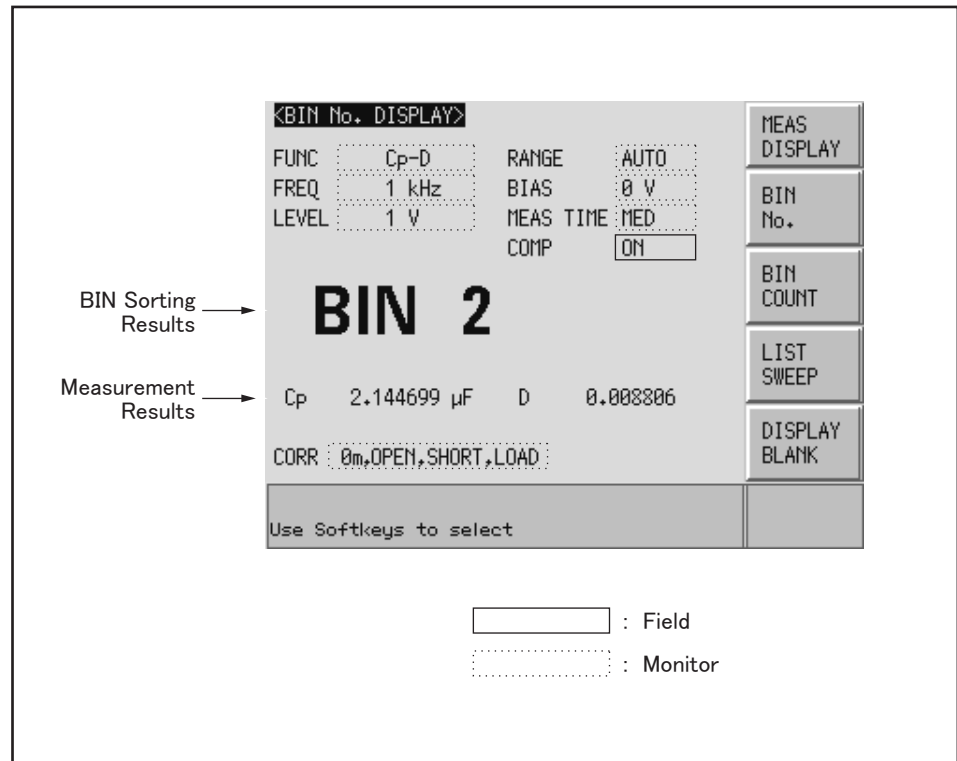

e4980aue1064

3. Display Format

Comparator Function ON/OFF

The E4980A's built-in comparator can sort devices into a maximum of ten bins (BIN 1 to BIN 9 and the OUT OF BIN) using a maximum of nine pairs of primary parameter limits and one pair of secondary parameter limits. Also, a device whose primary parameter is within limits, but whose secondary parameter measurement result is not, can be sorted into an auxiliary BIN (AUX BIN). To control a component handler using the comparator function, it is necessary to install option 201.

These limits settings for bin sorting are set on the LIMIT TABLE page from the [MEAS SETUP] key (refer to Chapter 4). Therefore, this COMP field allows you to only set the comparator function to ON or OFF.

Procedure for setting the comparator function

- Step 1.** Press the [Display Format] key.
- Step 2.** Press the **BIN No.** softkey.
- Step 3.** Use the cursor keys to select the COMP field.
- Step 4.** Use the softkeys to set the comparator function to ON or OFF.

Softkey	Function
ON	Sets the comparator to ON
OFF	Sets the comparator to OFF

BIN COUNT DISPLAY Page

When you press the [Display Format] key and **BIN COUNT** softkey, the BIN COUNT DISPLAY page is displayed. On this page, the comparator's count results are displayed (The field in parentheses is used for setting).

- Counter function ON/OFF (COUNT field)

This page also provides the following information in the monitor areas (each monitor area looks like a field, but is not). These conditions can be set from the LIMIT TABLE SETUP page. For more details, refer to "LIMIT TABLE SETUP Page" on page 133.

- Measurement Function (FUNC)
- Nominal Value (NOM)
- Test Frequency (FREQ)
- Bin Sorting Low/High Limits (LOW/HIGH)
- BIN Sorting Results (RESULT)

Figure 3-10 shows the available fields and the softkeys that correspond to each field on this page.

You can set it so that a beep sounds when the sorting result is output. For details, refer to "Beep Feature" on page 142.

Figure 3-10

BIN COUNT DISPLAY Page

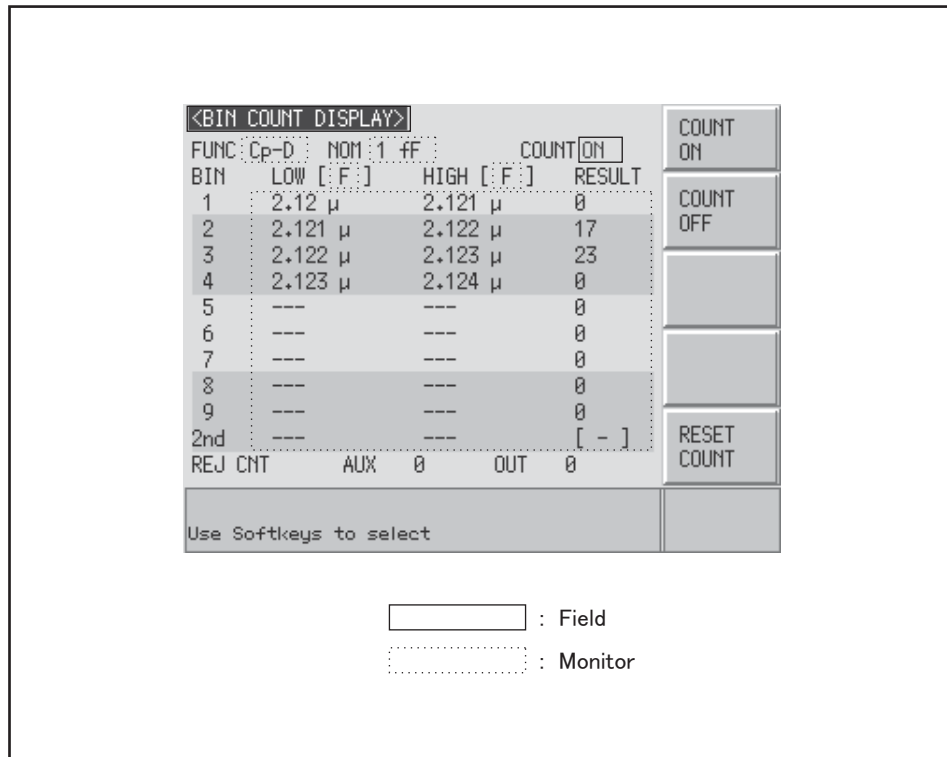

e4980aue1065

Counter Function

The E4980A is capable of counting bins. The number of devices sorted into each bin is counted while the unit sorts the devices into appropriate bins using the comparator function.

The maximum count is 999,999. The counting operation stops and the overflow message “----” appears when this value is reached.

Counter setting procedure

- Step 1.** Press the [Display Format] key.
- Step 2.** Press the **BIN COUNT** softkey.
- Step 3.** Use the cursor keys to select the COUNT field.
- Step 4.** Use the softkeys to set the counter to ON/OFF.

Softkey	Function
COUNT ON	Sets the counter to ON
COUNT OFF	Sets the counter to OFF

Counter reset procedure

- Step 1.** Press the [Display Format] key.
- Step 2.** Press the **BIN COUNT** softkey.
- Step 3.** Use the cursor keys to select the COUNT field.
- Step 4.** Use the softkeys to press **RESET COUNT**.

NOTE The counter is reset when the instrument setting state is recalled.

LIST SWEEP DISPLAY Page

When you press the [Display Format] key and **LIST SWEEP** softkey, the LIST SWEEP DISPLAY page appears. On this page it is possible to enter sweep points and measurement limits of up to 201 frequencies, test signal levels, DC bias, or DC source. The sweep points are automatically swept and the measurement results are compared to the limits.

On the LIST SWEEP DISPLAY page, the sweep points are swept and the measurement results are compared to the limits. During a sweep, an asterisk mark (*) will appear on the left side of the sweep point currently being measured. The following measurement controls can be set from this page (Each field in parentheses is used for setting).

- Sweep Mode of the List Sweep Measurement (MODE)
- Confirmation for Each Page of the List Sweep Measurement (No. of fields)

The sweep point list cannot be set from this page; it can only be set from the LIST SWEEP SETUP page.

Figure 3-11 shows the available fields and the softkeys that correspond to each field on this page.

You can set it so that a beep sounds when the sorting result is output. For details, refer to “Beep Feature” on page 142.

Figure 3-11 LIST SWEEP DISPLAY Page

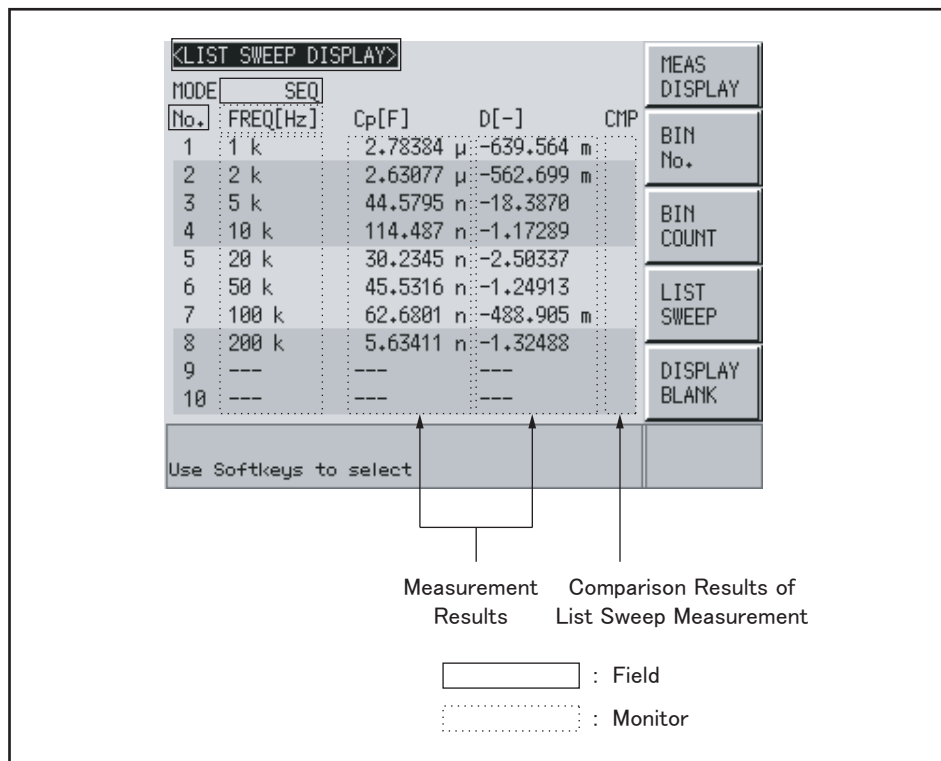

e4980aue1067

Sweep Mode

The E4980A's function for list sweep measurement permits up to 201 test frequencies, test signal levels, DC bias, or DC source to be automatically measured. There are two measurement methods for list sweep measurements: sequential (SEQ) mode and step (STEP) mode. In the case of SEQ mode, when the E4980A is triggered once, all sweep points are automatically swept. In the case of STEP mode, each time the E4980A is triggered, the sweep points are swept one by one.

Procedure for setting sweep modes

- Step 1.** Press the [Display Format] key.
- Step 2.** Press the **LIST SWEEP** softkey.
- Step 3.** Use the cursor keys to select the MODE field.
- Step 4.** Use the softkeys to select the sweep mode.

Softkey	Function
SEQ	When the E4980A is triggered once, all sweep points are swept
STEP	Each time the E4980A is triggered, the sweep points are swept one by one

Figure 3-12 Sequential mode and step mode

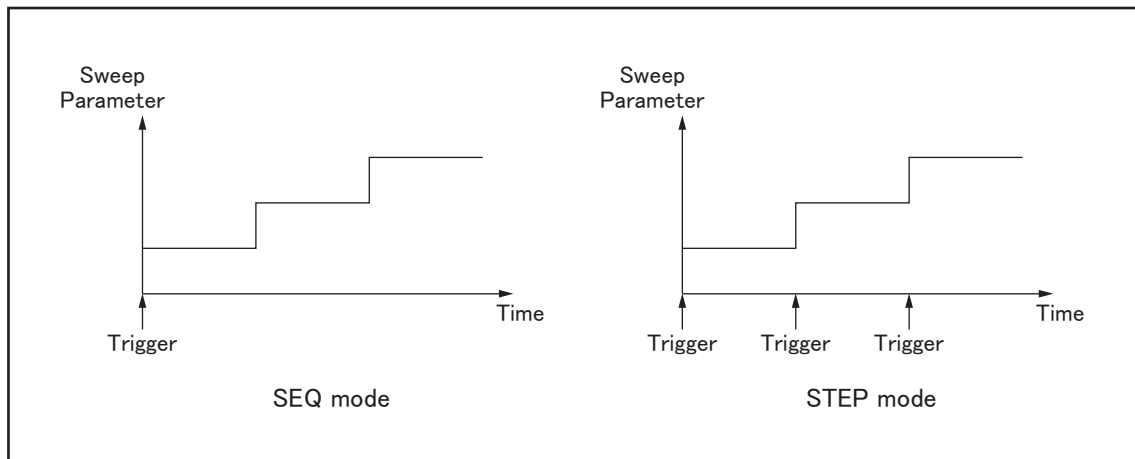

e4980aue1066

NOTE

When two or more sweep points are the same and are adjacent, the E4980A measures all of the listed points, and then compares the measurement result to limits set for each sweep point.

Procedure to confirm the sweep points

- Step 1.** Press the [Display Format] key.
- Step 2.** Press the **LIST SWEEP** softkey.
- Step 3.** Use the cursor keys to select the No. of fields.

Display Format
LIST SWEEP DISPLAY Page

Step 4. Use the softkeys to confirm the sweep points on each page.

Softkey	Function
PREV PAGE	Displays the previous page
NEXT PAGE	Displays the next page

DISPLAY BLANK Page

When you press the [Display Format] key and then press the **DISPLAY BLANK** softkey, the screen switches to the non-display state. In this state, measurement time decreases because the screen is not updated. For more on display time, refer to “Display time” on page 440 of Chapter 11, “Specifications and Supplemental Information.”

Press the **DISPLAY NORMAL** softkey to return to the normal screen.

Figure 3-13 shows the DISPLAY BLANK page.

Figure 3-13

DISPLAY BLANK page

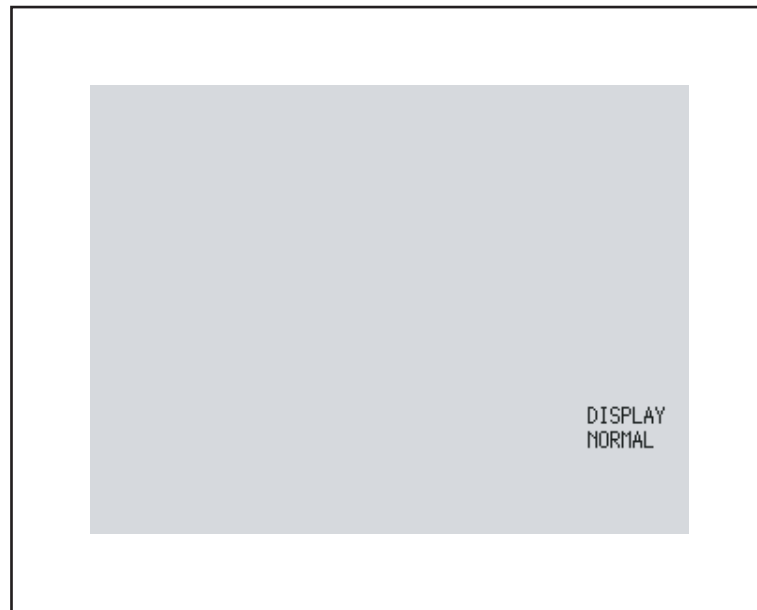

e4980auj1068

NOTE

The LCD backlight cannot be turned off.

Keys other than the **DISPLAY NORMAL** softkey are not available.

Even when the screen is in the non-display state and the front panel keys are unavailable (UNLOCK state), the **DISPLAY NORMAL** key is available.

4

**Configuring Measurement Conditions
(Display and Function Related Settings)**

This chapter provides information on the various settings accessible through the MEAS SETUP page of the E4980A.

Initializing the Instrument

The E4980A can be initialized into one of the following four default states:

Table 4-1

Three default states of E4980A and how it is initialized

Default state	How the instrument is initialized
CLEAR SETTING	When you initialize the instrument into this state, all basic parameters configurable through the front panel and SCPI commands are cleared. (You get the same result by issuing the *RST command).
CLEAR SET&CORR	When you initialize the instrument into this state, calibration data and backup items listed in the initial setting list are all cleared. *1(You can gain the same result by issuing the :SYST:PRES command).
FACTORY DEFAULT	When you initialize the instrument into this state, it reverts to factory default settings with all user-configurable data cleared.
LAN RESET	When you initialize the instrument into this state, the LAN setting is returned to the factory default state.

*1.It takes a few seconds for the initialization to complete.

For more information on each default state and affected settings, see Appendix C, “List of Default Values,” on page 473.

MEAS SETUP page

You can press the [Meas Setup] key to open the MEAS SETUP page. In the MEAS SETUP page, you can configure each of the following measurement controls with the cursor placed in the corresponding field (denoted in parentheses).

- Comment line (USER COMMENT field)
- Measurement function (FUNC field)
- Measurement range (RANGE field)
- Measurement frequency (FREQ field)
- DC bias (BIAS field)
- Measurement signal level (LEVEL field)
- Measurement time mode (MEAS TIME field)
- Trigger mode (TRIG field)
- averaging factor (AVG field)
- Automatic level control (ALC field)
- Signal voltage level monitor ON/OFF (VDC MON field)
- DC resistance range (DCR RNG field)
- Signal current level monitor ON/OFF (IDC MON field)
- Bias current isolation (DCI ISO field)
- Trigger delay time (TRIG DLY field)
- DC current (DCI) range (DCI RNG field)
- Step delay time (STEP DLY field)
- DC source (DC SRC field)
- Automatic bias polarity control (BIAS POL)
- Deviation measurement mode A (DEV A field)
- Reference value for deviation measurement mode A (REF A field)
- Deviation measurement mode B (DEV B field)
- Reference value for deviation measurement mode B (REF B field)

The following fields are accessible through both the MEAS SETUP and MEAS DISPLAY pages:

- Measurement function (FUNC field)
- Measurement range (RANGE field)
- Measurement frequency (FREQ field)
- DC bias (BIAS field)
- Measurement signal level (LEVEL field)
- Measurement time mode (MEAS TIME field)

Configuring Measurement Conditions (Display and Function Related Settings)
MEAS SETUP page

For more information on the fields listed above, refer to the description in Chapter 3, Display Format. The following sections give descriptions on the fields that are only accessible through the MEAS SETUP.

Figure 4-1 shows the fields available on this page along with the softkeys corresponding to them.

Figure 4-1 MEAS SETUP page

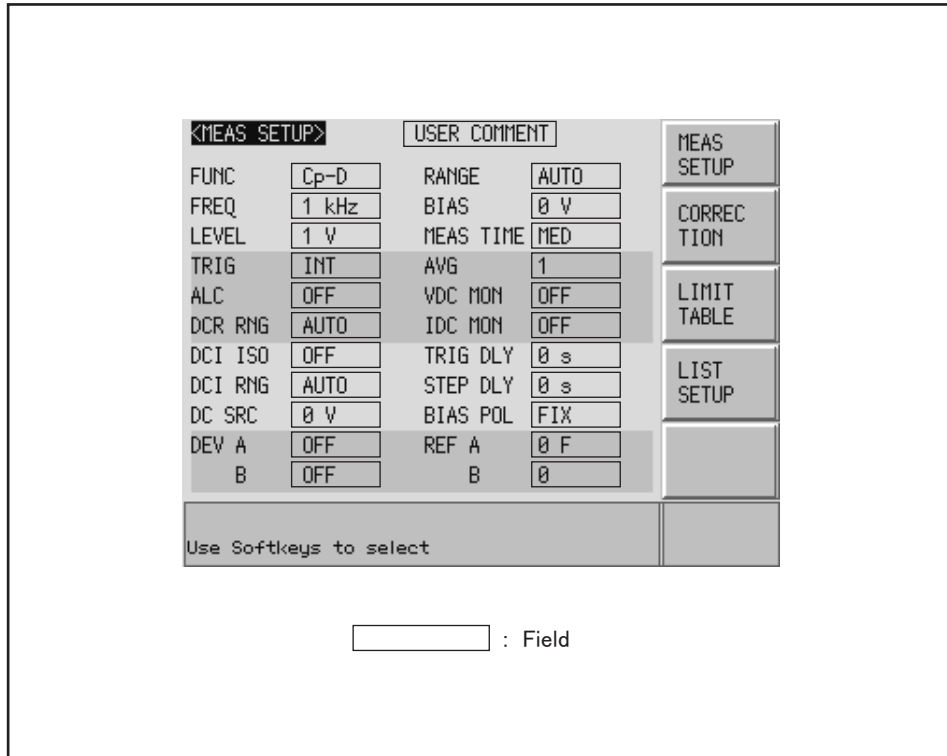

e4980aue1069

Comment line

You can enter a comment in the comment line by using the softkeys to enter letters and the entry keys to enter numbers from 0 through 9, +, -, and period (.). Your entered comment is saved in the internal memory or external USB memory along with the control settings of the E4980A. When you load the control settings, your saved comment is loaded as well.

The comment can be up to 30 characters in length. However, only the first 22 characters are displayed in the area.

Until you enter a comment into the comment line, the default text “USER COMMENT” appears in the comment line.

NOTE You can also use the DISPlay:LINE command to enter ASCII characters into the comment line.

To enter a comment into the comment line:

- Step 1.** Press [Meas Setup].
- Step 2.** Press the **MEAS SETUP** softkey.
- Step 3.** Using the cursor keys, select the USER COMMENT field.

NOTE If there is already a comment, select that comment (field).

- Step 4.** To input a letter, use the following softkeys to cycle through letters in alphabetical order and then select your desired letter:

Softkey	Description
NEXT	Displays the next letter to the letter currently displayed in the ADD CHAR softkey.
PREV	Displays the previous letter to the letter currently displayed in the ADD CHAR softkey.

NOTE To input a number, use the entry keys.

- Step 5.** Press the **ADD CHAR** softkey. Your selected single character appears in the input line area.
- Step 6.** Repeat Step 4 and Step 5 to input subsequent characters.
- Step 7.** Press the **ENTER** softkey to enter your text in the USER COMMENT field.

Trigger mode

Functional Description

The E4980A supports four trigger modes: INT (internal), EXT (external), MAN (manual), and BUS (GPIB bus).

For more on the E4980A's trigger system, see "Trigger System" on page 251 in Chapter 8, Overview of Remote Control

Trigger mode	Description
INT	After you bring up the display page using the [Display Format] key, the instrument continuously repeats the measurement cycle.
MAN	After you bring up the display page using the [Display Format] key, the instrument performs one cycle of measurement each time you press the [Trigger] key.
EXT	After you bring up the display page using the [Display Format] key, the instrument performs one cycle of measurement each time a rising TTL pulse is input to the external trigger input terminal on the rear panel. In the EXT (external trigger) mode, you can also trigger the instrument by short-circuiting the core wire of the external trigger input terminal and the instrument's ground line (the core wire is connected to a circuit that contains a pull-up resistor). Figure 4-2 shows the TTL pulse specifications. Also, you can trigger the instrument from the handler interface or scanner interface.
BUS	The E4980A performs one cycle of measurement each time it receives a trigger command sent via GPIB/USB/LAN.

NOTE

E4980A ignores any trigger that is input during a measurement cycle. Be sure to trigger the instrument when it is not in a measurement cycle.

Figure 4-2

External trigger pulse

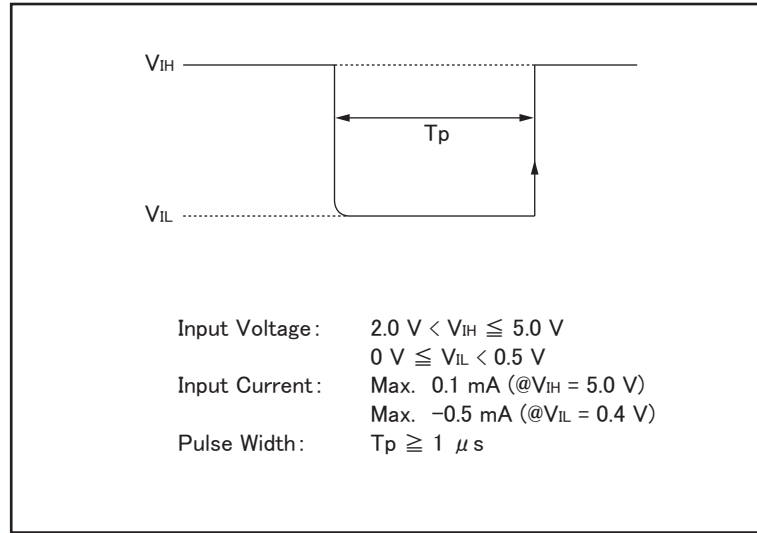

e4980aue1046

To choose a trigger mode:

- Step 1.** Press [Meas Setup].
- Step 2.** Using the cursor keys, select the TRIG field.
- Step 3.** Select your desired trigger mode by pressing the appropriate softkey:

Softkey	Description
INT	Puts the instrument into internal trigger (INT) mode.
MAN	Puts the instrument into manual trigger (MAN) mode.
EXT	Puts the instrument into external trigger (EXT) mode.
BUS	Puts the instrument into bus mode.

Automatic level control

Functional Description

The automatic level control (ALC) feature adjusts the voltage across the DUT to the same level as the signal voltage level setting or the current across the DUT to the same level as the signal current level setting. Using this feature, you can maintain a constant level (voltage or current) of measurement signals applied to the DUT.

The automatic level control feature uses a monitorable feedback circuit, as shown in Figure 4-3, to iterate a feedback loop that consists of level measurement and level change, two to nine times every measurement cycle. (The time required for level adjustment depends on how many times the feedback loop is iterated (the value “n”) and, in turn, the value “n” depends on the characteristics of the DUT. Generally, the higher the DUT’s non-linearity, the longer the level adjustment time.)

If the automatic level control feature fails to complete the level adjustment after it has iterated the feedback loop (level measurement and level change) nine times, it becomes inactive^{*1} and the warning message “ALC unable to regulate” appears. In this case, the signal input level is made equal to the specified level, and the signal output level is made equal to the output level with the automatic level control feature turned off.

The time required for the automatic level control feature to complete the adjustment can be determined based on the following formula:

When the measurement range is set to HOLD, (measurement time + test signal voltage setting time) × n,

where n = 2 (min)

n = 9 (max)

NOTE

For more on the test signal voltage setting time, refer to Table 11-30 on page 436 of Chapter 11, “Specifications and Supplemental Information”.

*1. If the DUT has a very high linearity, the automatic level control feature may turn inactive before it enters the 9th iteration of the feedback loop of the level measurement cycle and the level may change.

Figure 4-3

Feedback Circuit

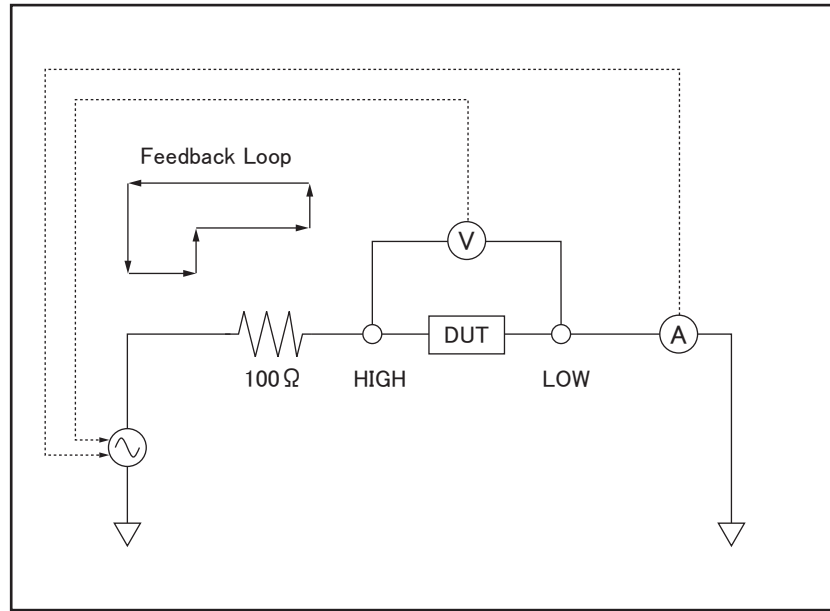

e4980aue1047

Figure 4-4 shows the working ranges of the automatic level control feature. In the charts, solid lines denote the ranges that apply when the DUT is a resistor, while broken lines denote the ranges for a capacitor or inductor.

NOTE

When test signal level is set close to 2 Vrms/20 mArms or 20 Vrms/100 mArms or less than 5 mVrms, the warning message “ALC unable to regulate” may appear.

Figure 4-4 Working ranges of the automatic level control feature

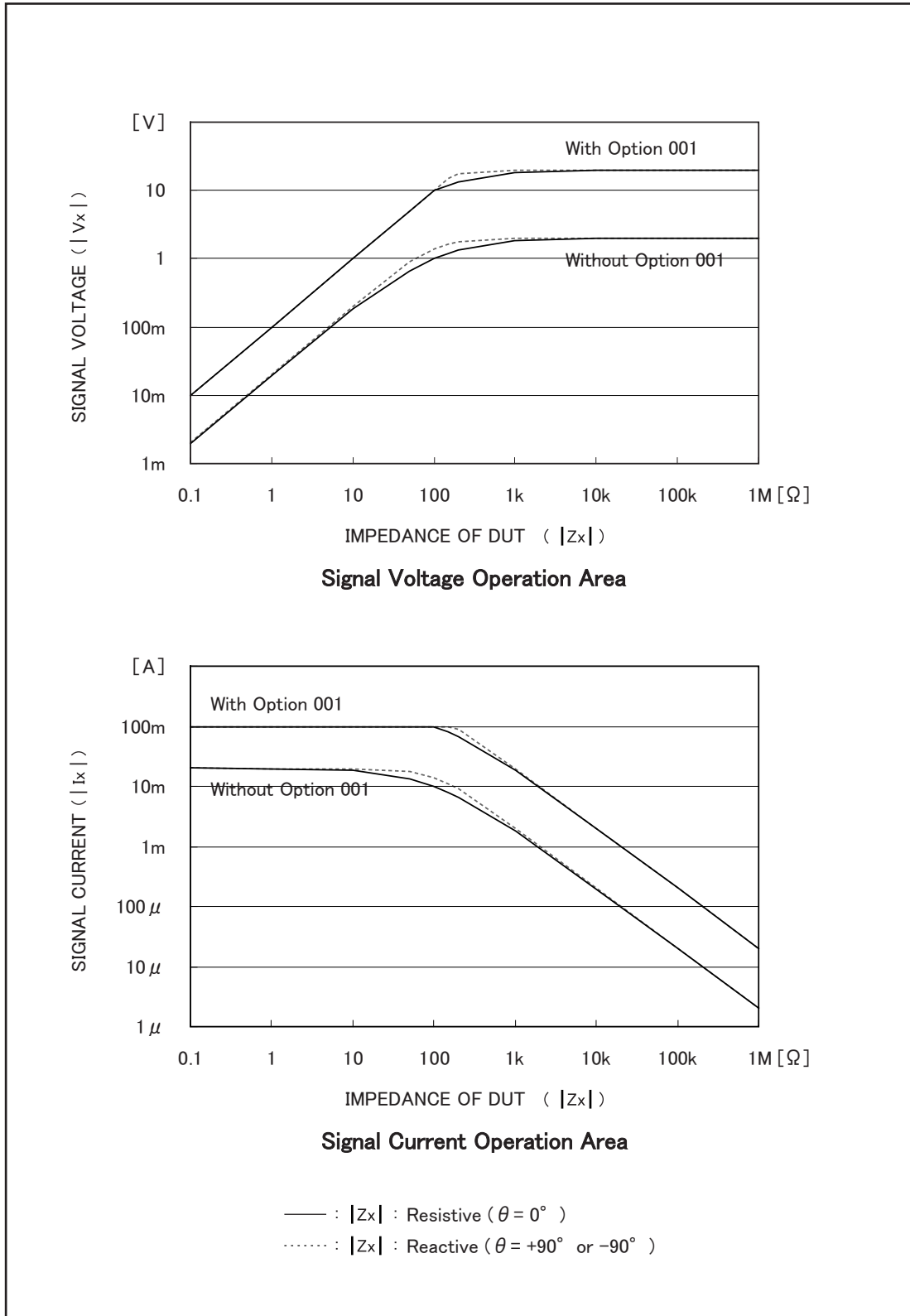

e4980aue1048

To set up the automatic level control feature:

- Step 1.** Press [Meas Setup].
- Step 2.** Using the cursor keys, select the ALC field.
- Step 3.** Use the following softkeys:

Softkey	Description
ON	Turns ON the automatic level control feature.
OFF	Turns OFF the automatic level control feature.

DC Bias Current Isolation

Functional Description

When the instrument is equipped with Option 001 (Power/DC Bias Enhance), it supports DC bias settings up to $\pm 40V$. The DC bias current actually applied to the DUT can be checked using the IDC monitor.

The DC bias current isolation feature is intended to prevent DC current from affecting the measurement circuit. To turn on/off this feature, use the DCI ISO field.

For information on the maximum DC bias current with the DC bias current isolation feature ON or OFF, see “Maximum DC bias current” on page 442 in Chapter 11, “Specifications and Supplemental Information”.

When the DC bias current isolation feature is OFF and the DC bias current applied to the DUT exceeds the maximum level, turn this feature ON. If a DC bias current exceeding the maximum level is applied to the DUT, the instrument will fail to return correct measurements.

NOTE

The DC bias current isolation feature affects measurement accuracy. For more information, see “Relative measurement accuracy with bias current isolation” on page 443 in Chapter 11, “Specifications and Supplemental Information”.

To set up the DC bias current isolation feature:

- Step 1.** Press [Meas Setup].
- Step 2.** Using the cursor keys, select the DCI ISO field.
- Step 3.** Use the following softkeys:

Softkey	Description
ON	Turn ON the DC bias current isolation feature.
OFF	Turn OFF the DC bias current isolation feature.

- Step 4.** Set the DCI measurement range. For more information, see “To set the DCI range:” on page 109.

Averaging Factor

Functional Description

The averaging feature of the E4980A allows you to obtain moving average values of successive measurement results.

You can specify the averaging factor within the range of 1 to 256 in steps of 1.

NOTE

The averaging feature does not affect the measurement results of the DC bias voltage monitor and DC bias current monitor even when a particular averaging factor is specified.

To set up the averaging factor:

- Step 1.** Press [Meas Setup].
- Step 2.** Using the cursor keys, select the AVG field.
- Step 3.** Enter the averaging factor using the softkeys or entry keys. If you have used the entry keys to enter the value, the softkey labels change to unit labels (x1).

Softkey	Description
INCR ++	Increments the averaging factor in steps of 1, 2, 4, 8, 16, 32, 64, 128, and 256.
INCR +	Increments the averaging factor in steps of 1.
DECR -	Decrements the averaging factor in steps of 1.
DECR --	Decrements the averaging factor in steps of 1, 2, 4, 8, 16, 32, 64, 128, and 256.

Trigger Delay Time

Functional Description

The trigger delay time feature of the E4980A allows you to adjust the time between triggering and start of measurement. When you carry out list sweep measurement, this trigger delay time is inserted into the first place of the list.

You can set the trigger delay time within the range of 0 through 999 s (seconds) in minimum units of 100 μ s.

This feature is useful when you use the E4980A in conjunction with the handler and want to trigger the E4980A after stabilizing the connection of the DUT.

To set the trigger delay time:

- Step 1.** Press [Meas Setup].
- Step 2.** Using the cursor keys, select the TRIG DLY field.
- Step 3.** Enter the trigger delay time using the softkeys or entry keys. If you have used the entry keys to enter the value, the softkey labels change to unit labels (ms, s).

Softkey	Description
INCR ++	Increments the trigger delay time in the resolution steps shown in Table 4-3.
INCR +	Increments the trigger delay time in the resolution steps shown in Table 4-3.
DECR -	Decrements the trigger delay time in the resolution steps shown in Table 4-3.
DECR --	Decrements the trigger delay time in the resolution steps shown in Table 4-3.

Table 4-2

Resolution steps that apply when setting the trigger delay time with INCR ++ / DECR --

INCR ++ / DECR -- (s)
0
1 m, 2 m, 3 m, •••, 9 m
10 m, 20 m, 30 m, •••, 90 m
100 m, 200 m, 300 m, •••, 900 m
1, 2, 3, •••, 9
10, 20, 30, •••, 90
100, 200, 300, •••, 900, 999

Table 4-3 Resolution steps that apply when setting the trigger delay time with INCR + / DECR -

Trigger delay time	Resolution
0 s through 100 ms	100 μ s
100 ms through 1 s	1 ms
1 s through 10 s	10 ms
10 s through 100 s	100 ms
100 s through 999 s	1 s

NOTE For the relationship between the trigger delay time and step delay time, refer to Figure 4-5 on page 105.

Step Delay Time

Functional Description

The step delay time feature of the E4980A allows you to delay the start of measurement at each step and before starting measurement by the automatic bias polarity control feature.

You can set the step delay time within the range of 0 through 999 s (seconds) in minimum units of 100 μ s.

To set the step delay time:

- Step 1.** Press [Meas Setup].
- Step 2.** Using the cursor keys, select the STEP DLY field.
- Step 3.** Enter the step delay time using the softkeys or entry keys. If you use the entry keys to enter the value, the softkey labels change to unit labels (ms, s).

Softkey	Description
INCR ++	Increments step delay time in resolution steps shown in Table 4-4.
INCR +	Increments step delay time in resolution steps shown in Table 4-5.
DECR -	Decrements step delay time in resolution steps shown in Table 4-5.
DECR --	Decrements step delay time in resolution steps shown in Table 4-4.

Table 4-4 Resolution steps when setting the step delay time with INCR ++ / DECR --

INCR ++ / DECR -- (s)
0
1 m, 2 m, 3 m, ..., 9 m
10 m, 20 m, 30 m, ..., 90 m
100 m, 200 m, 300 m, ..., 900 m
1, 2, 3, ..., 9
10, 20, 30, ..., 90
100, 200, 300, ..., 900, 999

Table 4-5 Resolution steps when setting the trigger delay time with INCR + / DECR -

Trigger delay time	Resolution
0 s through 100 ms	100 μ s
100 ms through 1 s	1 ms
1 s through 10 s	10 ms
10 s through 100 s	100 ms
100 s through 999 s	1 s

Figure 4-5 Trigger delay time and step delay time

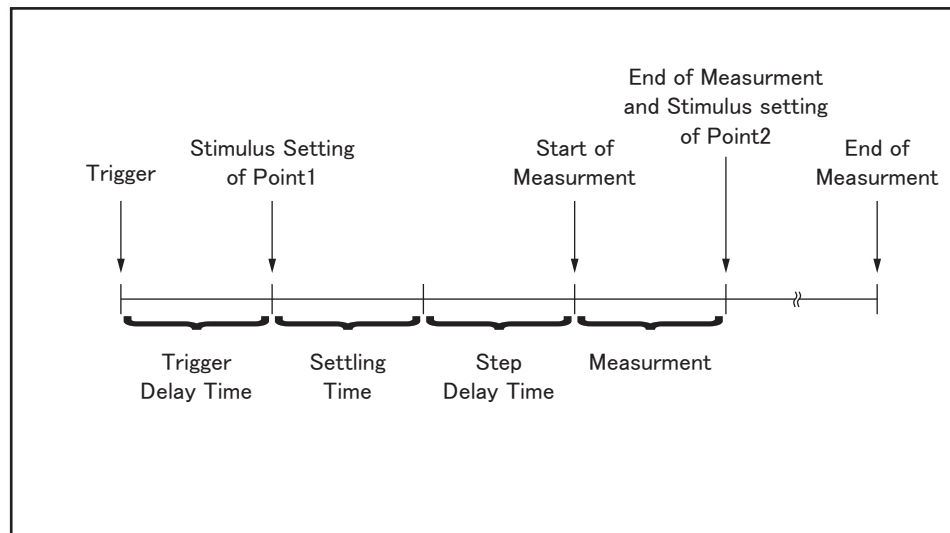

e4980aue1177

NOTE

In DCR measurement, there are two step delay times because two cycles of measurement are performed by applying +0.1 V and -0.1 V. Accordingly, when measuring the Rdc parameter such as Ls-Rdc, since the stimulus setting and measurement procedure is executed three times in one measurement, the step delay time takes three times as long as the setting value.

DC Bias Voltage Monitor

Functional Description

The DC bias voltage monitor feature allows you to monitor the actual level of the signal voltage across the DUT. The DC bias voltage monitor value is only displayed in the VDC monitor area of the MEAS DISPLAY page.

To set up the signal voltage level monitor feature:

- Step 1.** Press [Meas Setup].
- Step 2.** Using the cursor keys, select the VDC MON field.
- Step 3.** Use the following softkeys:

Softkey	Description
ON	Turn ON the DC bias voltage monitor feature.
OFF	Turn OFF the DC bias voltage monitor feature.

DC Bias Current Monitor

Functional Description

The DC bias current monitor feature allows you to monitor the actual level of the signal current across the DUT. The DC bias current monitor value is only displayed in the IDC monitor area of the MEAS DISPLAY page.

To set up the signal voltage level monitor feature:

- Step 1.** Press [Meas Setup].
- Step 2.** Using the cursor keys, select the IDC MON field.
- Step 3.** Use the following softkeys:

Softkey	Description
ON	Turn ON the DC bias current monitor feature.
OFF	Turn OFF the DC bias current monitor feature.

DCR Range

Functional Description

In DCR measurement, the E4980A's internal signal level is set to 0 V, and then two cycles of measurement are performed by applying +0.1 V and -0.1 V.

You can set the range for DCR measurement. DCR range can be set to one of five hold ranges, which are available when the measurement parameters are Lp-Rdc and Ls-Rdc.

Model	Measurement range (Ω)
Standard	10, 100, 1 k, 10 k, 100 k

NOTE When you set the DCR range to HOLD, DCI range and measurement range are also automatically set to HOLD; when you set the DCR range to AUTO, DCI range and measurement range are also automatically set to AUTO.

NOTE If you start DCR measurement with DC bias ON, DC bias is automatically turned OFF. When the measurement parameters are Lp-Rdc and Ls-Rdc, DC bias cannot be set to ON. An error message appears if you try to do this.

To set the DCR range:

- Step 1.** Press [Meas Setup].
- Step 2.** Press the **MEAS SETUP** softkey.
- Step 3.** Using the cursor keys, select the DCR RNG field.
- Step 4.** Enter the DCR range using the softkeys or entry keys. If you use the entry keys to enter the value, the softkey labels change to unit labels (Ω , k Ω).

Softkey	Description
AUTO	Sets the DCR range to AUTO.
HOLD	Sets the DCR range to HOLD (manual).
INCR +	Use this softkey to increment the measurement range. The DCR range changes to HOLD.
DECR -	Use this softkey to decrement the measurement range. The DCR range changes to HOLD.

DCI Range

Functional Description

You can set the range for DCI measurement. DCI range can be set to one of five hold ranges, which are available for DCI measurement.

Before setting the range for DCI measurement, it is necessary to set the DC bias current isolation feature to ON. For details, refer to “DC Bias Current Isolation” on page 100

Model	Measurement range (A)
Standard	20 μ , 200 μ , 2 m, 20 m, 100 m

NOTE When you set the DCI range to HOLD, DCR range and measurement range are also automatically set to HOLD; when you set the DCI range to AUTO, DCR range and measurement range are also automatically set to AUTO.

NOTE The initial value of DCI measurement range is set to 20 m at HOLD, so OVERLOAD is displayed when measure the current more than 20 m. In that case, set the DCI measurement range automatic or 100 m with following steps.

To set the DCI range:

- Step 1.** Press [Meas Setup].
- Step 2.** Using the cursor keys, select the DCI ISO field to set it to ON.
- Step 3.** Using the cursor keys, select the DCI RNG field.
- Step 4.** Enter the DCI range using the softkeys or entry keys. If you use the entry keys to enter the value, the softkey labels change to unit labels (μ A, mA, A).

Softkey	Description
AUTO	Sets the DCI range to AUTO.
HOLD	Sets the DCI range to HOLD (manual).
INCR +	Use this softkey to increment the measurement range. The DCI range changes to HOLD.
DECR -	Use this softkey to decrement the measurement range. The DCI range changes to HOLD.

DC Source

Functional Description

You can set the DC voltage that is output from the DC source output terminal within the range of -10 V through 10 V.

To set the DC source:

- Step 1.** Press [Meas Setup].
- Step 2.** Using the cursor keys, select the DC SRC field.
- Step 3.** Enter the DC source voltage using the softkeys or entry keys. If you use the entry keys to enter the value, the softkey labels change to unit labels (mV, V).

Softkey	Description
INCR ++	Increments the DC source voltage in the resolution steps shown in Table 4-3.
INCR +	Increments the DC source voltage in steps of 1 mV when lower than 1V or in steps of 10 mV when equal to or higher than 1V.
DECR -	Decrements Increments the DC source voltage in steps of 1 mV when lower than 1V or in steps of 10 mV when equal to or higher than 1V.
DECR --	Decrements the DC source voltage in the resolution steps shown in Table 4-3.

Table 4-6

Resolution steps when setting the DC source voltage with INCR ++ / INCR --

INCR ++ / INCR -- (V)
0 V
±1 m, ±2 m, ±3 m, •••, ±9 m
±10 m, ±20 m, ±30 m, •••, ±90 m
±100 m, ±200 m, ±300 m, •••, ±900 m
±1, ±2, ±3, •••, ±9
±10

Automatic Bias Polarity Control

Functional Description

The automatic bias polarity control feature is useful when testing a varactor diode. The E4980A identifies the connection state of the diode using an internal bias (approx. 1 V) and internally controls the DC bias polarity so that a reverse bias is applied to the diode.

For example, when a varactor diode is connected as shown in Figure 4-6, the E4980A recognizes that the diode is correctly connected and applies a DC bias in accordance with the specified setting. On the other hand, when a varactor diode is connected as shown in Figure 4-7, the E4980A recognizes that the diode is reverse-connected and applies a DC bias by inverting the polarity of the specified setting. This feature eliminates the need to check the polarity of a varactor diode before connecting it to the UNKNOWN terminal.

NOTE

When the DC bias feature is OFF and you set the automatic bias polarity control feature to AUTO, the automatic bias polarity control feature does not function.

Figure 4-6

Varactor diode (normal polarity)

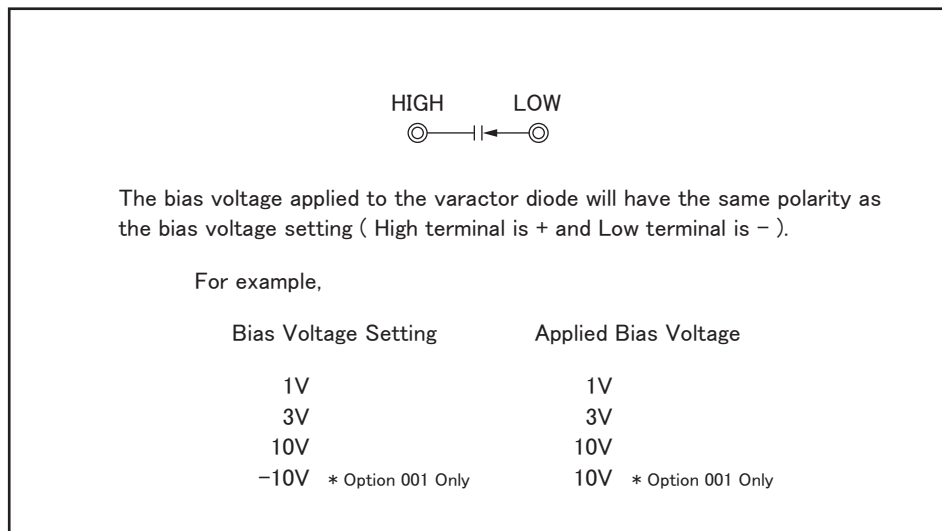

e4980aue1127

Figure 4-7

Varactor diode (reverse polarity)

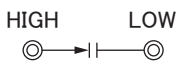

The bias voltage applied to the varactor diode will be the inverse of the bias voltage setting (High terminal is - and Low terminal is +).

For example,

Bias Voltage Setting	Applied Bias Voltage
1V	-1V
3V	-3V
10V	-10V
-10V * Option 001 Only	-10V * Option 001 Only

e4980aue1128

To set up the automatic bias polarity control feature:

- Step 1.** Press [Meas Setup].
- Step 2.** Using the cursor keys, select the BIAS POL field.
- Step 3.** Use the following softkeys:

Softkey	Description
AUTO	Sets the automatic bias polarity control feature to AUTO mode.
FIX	Sets the automatic bias polarity control feature to FIX mode.

Deviation Measurement

Functional Description

The deviation measurement feature allows you to display deviation values instead of actual measurements. A deviation is expressed as the difference between the actual measurement and the stored reference value. The deviation measurement feature is useful when you observe how a particular value of a device/component changes under varying conditions of temperature, frequency, bias, and other influences.

You can apply the deviation measurement feature to the primary or secondary parameter or both. The deviation measurement feature supports the following two modes:

- Δ ABS (absolute value) deviation measurement

Identifies and displays the difference between the actual measurement of the DUT and the stored reference value. This value is calculated based on the following formula:

$$\Delta\text{ABS} = X - Y$$

X actual measurement of the DUT

Y stored reference value

- $\Delta\%$ (percentage) deviation measurement

Identifies the difference between the actual measurement of the DUT and the stored reference value and displays it as a percentage of the reference value. This percentage deviation value is calculated based on the following formula:

$$\Delta\% = (X - Y) / Y \times 100 (\%)$$

X actual measurement of the DUT

Y stored reference value

To set up the deviation measurement feature:

- Step 1.** Press [Meas Setup].
- Step 2.** Using the cursor keys, select the REF A field.
- Step 3.** Enter the reference value using the softkeys or entry keys. If you use the entry keys to enter the value, the softkey labels change to unit labels (n, u, m, x1, k). *1

Softkey	Description
MEASURE	If you want to use a particular device/component as the reference, connect the DUT and press this key. Then the instrument measures the DUT once and automatically fills the REF A and (REF) B fields with the measured values, which now serve as the reference values.

*1. If the primary parameter of the measurement function is C, the softkey labels show these units: p, n, u, m, x1.

Step 4. Using the cursor keys, select the DEV A field.

Step 5. Select the deviation mode for the primary parameter by pressing the appropriate softkey:

Softkey	Description
ABS	Displays the deviation as the difference from the reference value.
%	Displays the deviation as a percentage of the reference value.
OFF	Turns OFF deviation measurement.

Step 6. Using the cursor keys, select the (DEV) B field.

Step 7. Select the deviation mode for the primary parameter using the softkeys described in Step 5.

CORRECTION page

Pressing the [Meas Setup] key followed by the **CORRECTION** opens the CORRECTION page. The CORRECTION page allows you to perform Open/Short/Load correction to compensate for any error caused by disturbances such as stray admittances and residual impedances. It also allows you to select the cable length.

The correction feature supports the following two correction methods:

- Correction based on all frequency points
- Correction based on user-specified frequency points

Correction based on all frequency points involves performing open/short correction at all measurement points throughout the entire frequency range.

Correction based on user-specified frequency points involves performing open/short/load correction at the user-specified frequency points.

Each correction dataset can be deleted by using the [Preset] key. For more information, see “Initializing the Instrument” on page 90.

NOTE

Correction when measuring DC resistance is performed only when the measurement parameter is Lp-Rdc and Ls-Rdc.

In this page, you can configure each of the following controls with the cursor placed in the corresponding field (denoted in parentheses).

- Open correction (OPEN field)
- Short correction (SHORT field)
- Load correction (LOAD field)
- Cable length selection (CABLE field)
- Multiple/single correction mode selection (MODE field)
- Measurement function for load correction (FUNC field)
- Channel selection for multiple correction mode (CH field)
- User-specified frequencies 1 to 201 for open/load/short correction (SPOT and FREQ fields)
- Measurement value and reference value at specified frequency points for open/short/load correction (REF A, REF B, OPEN A, OPEN B, SHORT A, SHORT B, LOAD A, and LOAD B fields)

Figure 4-8 shows the fields available on this page along with the softkeys corresponding to them.

Figure 4-8

CORRECTION page

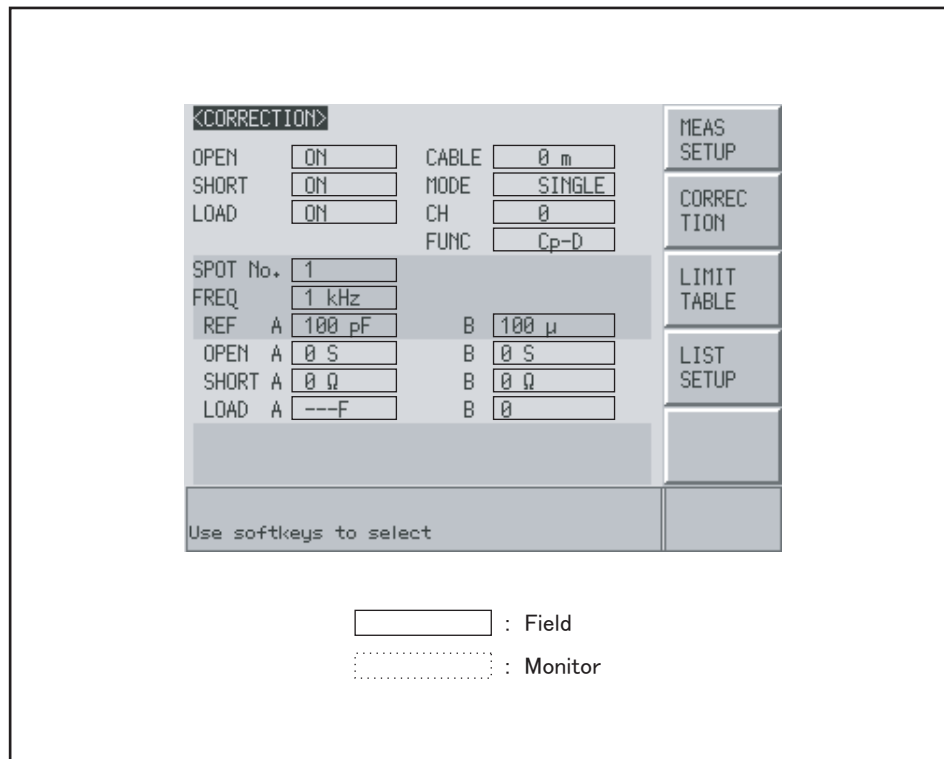

e4980aue1070

To set the correct function to on or off

Open/short correction at all frequency points and open/short/load correction at user-specified spot frequency points can be enabled or disabled by entering ON or OFF (with softkeys) in the OPEN, SHORT and LOAD fields on the CORRECTION display page. The on/off settings in the OPEN, SHORT and LOAD fields determine the on/off state of both open/short correction at all frequency points and open/short/load correction at user-specified spot frequency points. Accordingly, open/short/load correction at user-specified spot frequency points can be performed only when open/short correction at all frequency points is activated.

When the settings of the OPEN, SHORT and LOAD fields are ON, both open/short correction at all frequency points and open/short/load correction at user-specified spot frequency points are enabled. Open/short/load correction at user-specified spot frequency points are not carried out by setting FREQ field (below SPOT NO. field) to default OFF state. By entering a desired frequency in the FREQ field allocated to SPOT NO. from 1 to 201, open/short/load correction at the user-specified spot frequency is carried out. Open/short /load correction at user-specified spot frequency points takes priority over open/short correction at all frequency points when test frequency is identical with one of the user-specified spot frequency points.

The correction functions of the E4980A are operated as follows:

On/off setting in OPEN, SHORT and LOAD fields	OFF	ON
Open/short correction at all frequency points	Not Performed	Open/short correction at 51 preset frequency points is performed. Correction at other frequency points is performed by using interpolation based on the correction data at the preset frequencies adjacent to the test frequency.
Open/short/load correction at user-specified spot frequency points	Not Performed	Open/short/load correction at user-specified spot frequency points is performed in place of open/short correction at all frequency points when test frequency is identical with one of the user-specified spot frequency points.

Open Correction

The open correction feature of the E4980A compensates for any stray admittances (G, B) that may exist within the interval from the calibration plane, which is determined by the selected cable length, to the DUT connecting points (see Figure 4-9).

Figure 4-9

Stray admittances

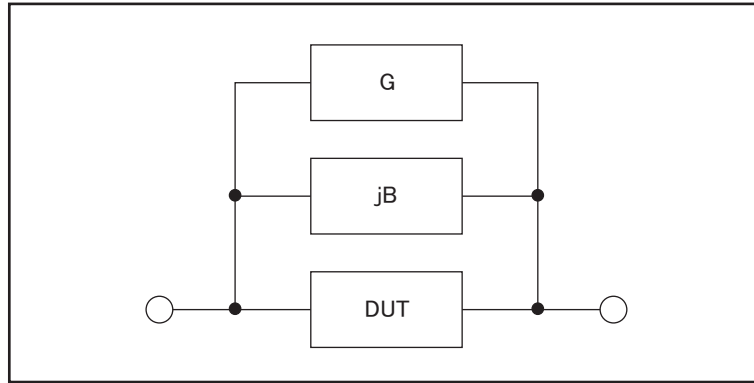

e4980aue1045

Description of Correction Based on All Frequency Points

In this correction method, open correction data are collected from all 51 predetermined frequency points, regardless of the test frequency settings. At the other frequency points, correction is done using data calculated by interpolating the data collected at the 51 points (see Figure 4-10). The following tables list the 51 predetermined frequency points:

Table 4-7

Predetermined frequency points in correction based on all frequency points

Test frequency points					
20 Hz	100 Hz	1 kHz	10 kHz	100 kHz	1 MHz
25 Hz	120 Hz	1.2 kHz	12 kHz	120 kHz	1.2 MHz
30 Hz	150 Hz	1.5 kHz	15 kHz	150 kHz	1.5 MHz
40 Hz	200 Hz	2 kHz	20 kHz	200 kHz	2 MHz
50 Hz	250 Hz	2.5 kHz	25 kHz	250 kHz	
60 Hz	300 Hz	3 kHz	30 kHz	300 kHz	
80 Hz	400 Hz	4 kHz	40 kHz	400 kHz	
	500 Hz	5 kHz	50 kHz	500 kHz	
	600 Hz	6 kHz	60 kHz	600 kHz	
	800 Hz	8 kHz	80 kHz	800 kHz	

Figure 4-10

Open/short correction using the interpolation method

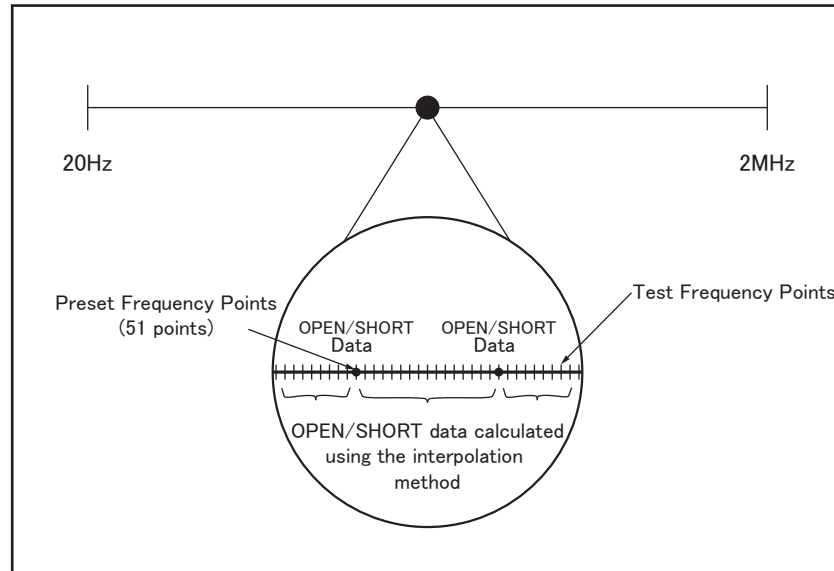

e4980aue1049

To carry out open correction based on all frequency points:

- Step 1.** Press [Meas Setup].
- Step 2.** Press the **CORRECTION** softkey.
- Step 3.** Using the cursor keys, select the OPEN field.
- Step 4.** Connect the UNKNOWN terminal and the text fixture with no DUT connected.
- Step 5.** Press the **MEAS OPEN** softkey. The E4980A measures open admittances (capacitances and conductances) at the 51 test frequency points.
 - During the measurement, an “OPEN measurement in progress” message is shown on the display.
 - When the measurement has finished, the “OPEN measurement in progress” message disappears.
 - During the measurement, the **ABORT** softkey is shown. Use this key when you want to abort open correction.

Step 6. Press the **ON** key to enable open correction in successive measurements.

Description of Softkeys

To enable/disable or otherwise control the behavior of open correction, use the following softkeys:

Softkey	Description
ON	Enables open correction.
OFF	Disables open correction.
MEAS OPEN	Starts open correction.

Short Correction

Functional Description

The short correction feature of the E4980A compensates for any residual impedances (R, X) that may exist within the interval from the calibration plane, which is determined by the selected cable length, to the DUT connecting points (see Figure 4-11).

Figure 4-11

Residual impedances

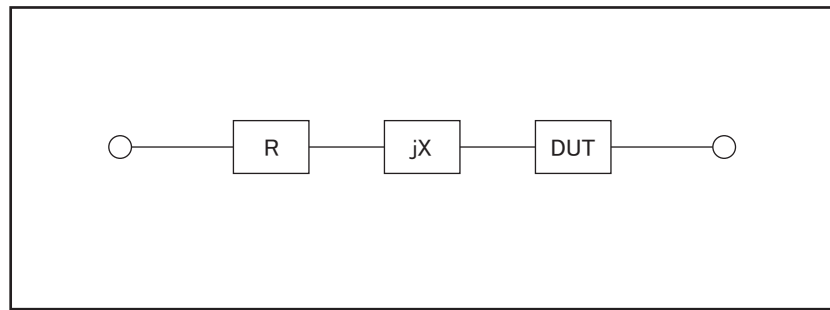

e4980aue1050

To carry out short correction:

- Step 1.** Press [Meas Setup].
- Step 2.** Press the **CORRECTION** softkey.
- Step 3.** Using the cursor keys, select the **SHORT** field.
- Step 4.** Connect the UNKNOWN terminal and the test fixture and short-circuit the high and low test terminals.
- Step 5.** Press the **MEAS SHORT** softkey. The E4980A measures short circuit impedances (inductances and resistances) at the 51 test frequency points.
 - During the measurement, a “SHORT measurement in progress” message is shown on the display.
 - When the measurement has finished, the “SHORT measurement in progress” message disappears.
 - During the measurement, the **ABORT** softkey is shown. Use this key when you want to abort short correction.

Step 6. Press the **ON** key to enable short correction in successive measurements.

Description of the Softkeys

To enable/disable or otherwise control the behavior of short correction, use the following softkeys:

Softkey	Description
ON	Enables short correction.
OFF	Disables short correction.
MEAS SHORT	Starts short correction.

NOTE

When the test signal current exceeds a value shown in Table 11-6, a “Signal source overload” warning appears and measurement may not be correct. When performing **SHORT** correction, reduce the test signal level so that the signal current doesn’t exceed values shown in Table 11-6.

Correction Based on User-Specified Frequency Points

Description of Correction Based on User-Specified Frequency Points

Correction based on user-specified frequency points involves performing open/short/load correction at frequency points specified by user. You can specify up to 201 frequency points as needed.

For examples and instructions on using the correction features, see “Correction Functions” on page 211.

In addition to the open/short correction features, the E4980A provides a load correction feature that allows you to carry out, at your specified frequency points, load correction using a transfer function determined based on the relationships between a particular standard’s reference values (pre-measured, known values) and the standard’s actual measurements. With load correction, you can compensate for errors that cannot be compensated using open/short correction.

Open/short/load correction can be performed at up to 201 specified frequency points, as shown in Figure 4-12. You can define these frequency points using the SPOT No. fields. To specify the standard’s reference values, use the A and B fields. Before entering the standard’s reference values, you need to set the measurement function using the FUNC field. To obtain the standard’s actual measurements, use the softkey, which appears when you move the cursor into the FREQ field.

Figure 4-12 Open/short/load correction

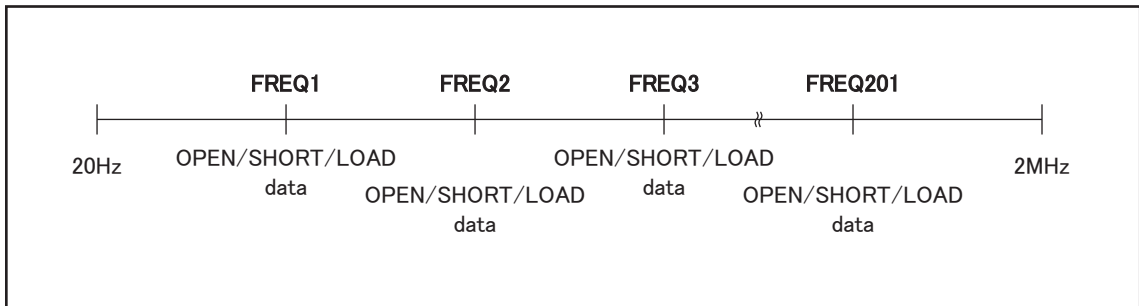

e4980aue1051

To specify frequency points and carry out open correction:

- Step 1.** Press [Meas Setup].
- Step 2.** Press the **CORRECTION** softkey.
- Step 3.** Using the cursor keys, select the SPOT No. field.
- Step 4.** Enter the measurement point number using the softkeys or entry keys. If you have used the entry keys to enter the value, the softkey labels change to unit labels (x1).

You can specify up to 201 measurement points.

Softkey	Description
INCR ++	Increments the measurement point number in steps of 10.
INCR +	Increments the measurement point number in steps of 1.

Softkey	Description
DECR -	Decrements the measurement point number in steps of 1.
DECR --	Decrements the measurement point number in steps of 10.

Step 5. Using the cursor keys, select the **FREQ** field.

Step 6. Enter the frequency using the entry keys. When you have entered the frequency, the softkey labels change to unit labels (Hz, kHz, MHz).

Step 7. Press the **ON** softkey.

Step 8. Connect the UNKNOWN terminal and the text fixture with no DUT connected.

Step 9. Press the **MEAS OPEN** softkey.

- During the measurement, an “OPEN measurement in progress” message is shown on the display.
- When the measurement has finished, the “OPEN measurement in progress” message disappears.
- During the measurement, the **ABORT** softkey is shown. Use this key when you want to abort open correction

Step 10. Repeat Step 3 to Step 9 until you have specified all of your desired measurement points.

Step 11. Move the cursor into the **OPEN** field.

Step 12. Press the **ON** key to enable the open correction feature.

To specify frequency points and carry out short correction:

Step 1. Press [Meas Setup].

Step 2. Press the **CORRECTION** softkey.

Step 3. Using the cursor keys, select the **SPOT No.** field.

Step 4. Enter the measurement point number using the softkeys or entry keys. If you have used the entry keys to enter the value, the softkey labels change to unit labels (x1).

You can specify up to 201 measurement points.

Softkey	Description
INCR ++	Increments the measurement point number in steps of 10.
INCR +	Increments the measurement point number in steps of 1.
DECR -	Decrements the measurement point number in steps of 1.
DECR --	Decrements the measurement point number in steps of 10.

Step 5. Using the cursor keys, select the **FREQ** field.

Step 6. Enter the frequency using the entry keys. When you enter the frequency, the softkey labels change to unit labels (Hz, kHz, MHz).

- Step 7.** Press the **ON** softkey.
- Step 8.** Connect the UNKNOWN terminal and the test fixture and short-circuit the HIGH and LOW test terminals.
- Step 9.** Press the **MEAS SHORT** softkey.
- During the measurement, a “SHORT measurement in progress” message is shown on the display.
 - When the measurement has finished, the “SHORT measurement in progress” message disappears.
 - During the measurement, the **ABORT** softkey is shown. Use this key when you want to abort short correction
- Step 10.** Repeat Step 3 to Step 9 until you have specified all of your desired measurement points.
- Step 11.** Move the cursor into the SHORT field.
- Step 12.** Press the **ON** key to enable the short correction feature.

To specify frequency points and carry out load correction:

- Step 1.** Press [Meas Setup].
- Step 2.** Press the **CORRECTION** softkey.
- Step 3.** Using the cursor keys, select the SPOT No. field.
- Step 4.** Enter the measurement point number using the softkeys or entry keys. If you use the entry keys to enter the value, the softkey labels change to unit labels (x1).

You can specify up to 201 measurement points.

Softkey	Description
INCR ++	Increments the measurement point number in steps of 10.
INCR +	Increments the measurement point number in steps of 1.
DECR -	Decrements the measurement point number in steps of 1.
DECR --	Decrements the measurement point number in steps of 10.

- Step 5.** Using the cursor keys, select the **FREQ** field.
- Step 6.** Enter the frequency using the entry keys. When you enter the frequency, the softkey labels change to unit labels (Hz, kHz, MHz).
- Step 7.** Press the **ON** softkey.
- Step 8.** Move the cursor into the **REF A** field.
- Step 9.** Enter the known value of the standard’s primary parameter using the softkeys or entry keys.
- Step 10.** Move the cursor into the **REF B** field.
- Step 11.** Enter the known value of the standard’s secondary parameter using the softkeys or entry

keys.

Step 12. Move the cursor into the **FREQ** field.

Step 13. Connect the standard to the **UNKNOWN** terminal.

Step 14. Press the **MEAS LOAD** softkey.

- During the measurement, a “LOAD measurement in progress” message is shown on the display.
- When the measurement has finished, the “LOAD measurement in progress” message disappears.
- During the measurement, the **ABORT** softkey is shown. Use this key when you want to abort load correction

Step 15. Repeat Step 3 to Step 14 until you have specified all of your desired measurement points.

Step 16. Move the cursor into the **LOAD** field.

Step 17. Press the **ON** key to enable the load correction feature.

Description of Softkeys

To enable/disable or otherwise control the behavior of correction based on specified frequency points, use the following softkeys:

Softkey	Description
ON	Enables the current measurement point number.
OFF	Disables the current measurement point number.
MEAS OPEN	Starts open correction.
MEAS SHORT	Starts short correction.
MEAS LOAD	Starts load correction.

Relationships between Correction Based on All Frequency Points and Correction Based on Specified Frequency Points

Figure 4-13 shows the CORRECTION page and how the open/short/load correction features are related to each other.

Figure 4-13

How correction features are related to each other

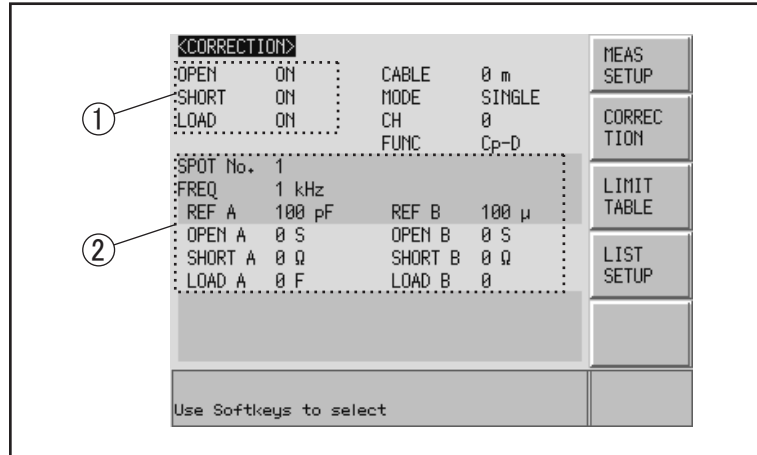

e4980auj1131

1. This area is used to:

- Carry out correction calculation using either the open/short correction data generated by the interpolation method or the open/short/load correction data at specified frequency points.

Which data is used depends on the test frequencies.

- Obtain the open/short correction data.

2. This area is used to:

- Obtain the open/short/load correction data at each frequency point specified in the **FREQ** field.
- Enable or disable the open/short/load correction data at each frequency point specified in the **FREQ** field.

The following tables show how correction data elements are related to each other when the correction features are enabled in the **OPEN**, **SHORT**, and **LOAD** fields. Correction data elements are selected based on the number of measurement points.

- When test frequency point is equal to the frequency point specified in **FREQ** field:

Correction	Frequency point specified in FREQ field	
	ON	OFF
OPEN: ON	User-specified	Interpolated
SHORT: ON	User-specified	Interpolated
LOAD: ON	User-specified	X

Configuring Measurement Conditions (Display and Function Related Settings)
CORRECTION page

- When test frequency point is NOT equal to the frequency point specified in **FREQ** field:

Correction	Frequency point specified in FREQ field	
	ON	OFF
OPEN: ON	Interpolated	Interpolated
SHORT: ON	Interpolated	Interpolated
LOAD: ON	X	X

User-specified Correction data at your specified frequency point are used.

Interpolated Correction data generated by interpolation are used.

X Correction is not performed even when correction features are enabled in **OPEN**, **SHORT**, and **LOAD** fields.

NOTE

When you specify a frequency point whose frequency value is identical to that of an existing frequency point and turn on the correction feature for both points, the frequency point with the smaller measurement point number (**SPOT No.** field) is selected as the correction data.

Reading/Writing Correction Data

The E4980A allows you to read and write the correction data.

To write the correction data:

- Step 1.** Press the [Meas Setup] key.
- Step 2.** Press the **CORRECTION** softkey.
- Step 3.** Using the cursor keys, select the SPOT No. field and enter the measurement point number.
- Step 4.** Using the cursor keys, select the FREQ field and enter the frequency.
- Step 5.** Using the cursor keys, select these fields: OPEN A, SHORT A, LOAD A, OPEN B, SHORT B, and LOAD B.
- Step 6.** Enter the correction data using the softkeys or entry keys. If you use the entry keys to enter the value, the softkey labels change to unit labels (p, n, u, m, x1).

Measurement Functions for the Standard

Functional Description

When you perform load correction, you have to use the reference value of the standard (either known or pre-measured value). You can select only one of the available measurement functions as the reference value. For more information on the available measurement functions, see “Measurement Function” on page 54.

The load correction feature compensates for error by using a transmission coefficient derived from the relationship between the standard’s reference value and the actual measurement. Your selected measurement function is used solely for the calculation of the transmission function.

To set up the measurement function:

- Step 1.** Press [Meas Setup].
- Step 2.** Press the **CORRECTION** softkey.
- Step 3.** Using the cursor keys, select the FUNC field.
- Step 4.** Using the cursor keys, select the primary parameter.
- Step 5.** If there is a secondary parameter and you are presented with another list of measurement parameters, select one of them by using the softkeys.

NOTE

For more information on measurement parameters, see “Measurement Function” on page 54.

Selecting Single/Multiple Correction Mode

Functional Description

When equipped with Option 301 (Scanner Interface), E4980A can store up to 128 sets of open/short/load correction data. In addition, it can store one set of the standard's reference value data at a specified frequency point. In multiple correction mode, you can switch among up to 128 data sets to carry out correction. Note that the correction features default to single correction mode.

NOTE

When you use multiple correction mode, you cannot perform open/short correction by the interpolation method (open/short correction at particular frequency points) but must perform correction at specified frequency points.

User-specified frequency points can be configured separately between single and multiple correction modes.

In multiple correction mode, the channel number for which correction data are selected is displayed on the right-hand side of the CH indicator.

To set up single/multiple correction mode:

- Step 1.** Press [Meas Setup].
- Step 2.** Press the **CORRECTION** softkey.
- Step 3.** Using the cursor keys, select the MODE field.
- Step 4.** Use the following softkeys:

Softkey	Description
SINGLE	Turns ON single correction mode.
MULTI	Turns ON multiple correction mode.

NOTE

For more information on measurement parameters, see "Measurement Function" on page 54.

NOTE

When Option 301 (Scanner Interface) is not installed and you attempt to switch to multiple correction mode, a Scanner I/F not installed error message appears in the system message area.

Selecting the Cable Length

Functional Description

The E4980A has four reference planes (points): the UNKNOWN terminal (0 m), the tip of the 16048A/B test lead (1 m), the tip of the 16048D test lead (2 m), and the tip of the 16048E test lead (4 m). These points serve as the basis for the measurement accuracy.

When you select a cable length of 0 m, you have to use the UNKNOWN terminal to interconnect the outer contacts of lead wires Hcur, Hpot, Lpot, and Lcur.

When you select a cable length of 1 m, you have to use the tip of the 16048A/B 1m test lead to interconnect the outer contacts of lead wires Hcur, Hpot, Lpot, and Lcur.

When you select a cable length of 2 m, you have to use the tip of the 16048D 2m test lead to interconnect the outer contacts of lead wires Hcur, Hpot, Lpot, and Lcur.

When you select a cable length of 4 m, you have to use the tip of the 16048E 4m test lead to interconnect the outer contacts of lead wires Hcur, Hpot, Lpot, and Lcur.

The four-terminal pair structure is terminated at the tip of your selected cable length. When you use the 16048A/B/D/E test lead, connect the supplied terminal plate to the tip of the cable to terminate the four-terminal pair structure.

To select the cable length:

- Step 1.** Press [Meas Setup].
- Step 2.** Press the **CORRECTION** softkey.
- Step 3.** Using the cursor keys, select the CABLE field.
- Step 4.** Use the following softkeys:

Softkey	Description
0 m	Sets the cable length to 0 m (none).
1 m	Sets the cable length to 1 m.
2 m	Sets the cable length to 2 m.
4 m	Sets the cable length to 4 m.

LIMIT TABLE SETUP Page

Pressing the [Meas Setup] key followed by the **LIMIT TABLE** softkey opens the LIMIT TABLE SETUP page. The LIMIT TABLE SETUP page allows you to configure the E4980A's built-in comparator.

The built-in comparator can sort DUTs into a maximum 10 levels (BIN1 through BIN9 and OUT OF BINS) using up to nine sets of primary parameter limits along with one set of secondary parameter limits. In addition, DUTs that fall within the primary parameter limits but are out of the secondary parameter limits can be sorted into an auxiliary bin.

The comparator counts DUTs up to 999999. When this number is reached, the screen shows “-----” and the counting stops.

To take full advantage of the comparator, we recommend that you equip the E4980A with the handler interface option for use in conjunction with the comparator. The limits for bin sorting can only be configured on the LIMIT TABLE SETUP.

In this page, you can configure each of the following controls with the cursor placed in the corresponding field (denoted in parentheses).

- Measurement function (FUNC field)
- Comparator limit mode (MODE field)
- Tolerance mode nominal value (NOM field)
- Auxiliary bin ON/OFF (AUX field)
- Comparator ON/OFF (COMP field)
- Beep feature (BEEP field)
- Low limit for each bin (LOW field)
- High limit for each bin (HIGH field)

Figure 4-14 shows the fields available on this page along with the softkeys corresponding to them.

Figure 4-14

LIMIT TABLE SETUP Page

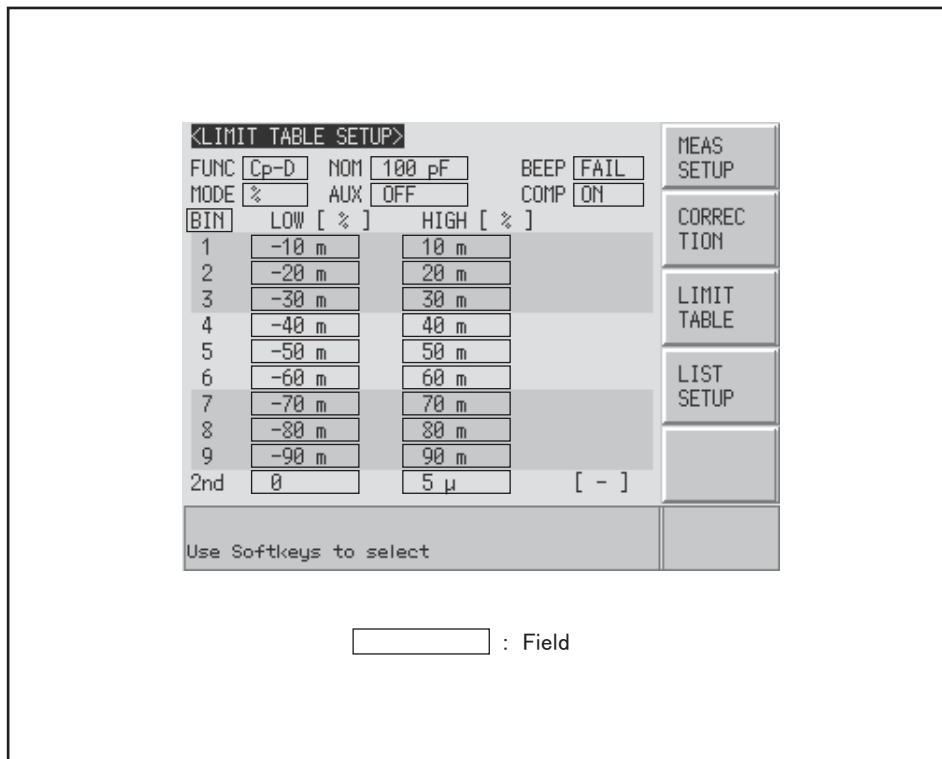

e4980aue1071

Parameter Swap Feature

Functional Description

The parameter swap feature exchanges the primary and secondary parameters in the FUNC field with each other. For example, when the measurement function is Cp-D and you use the parameter swap feature, the measurement function is changed to D-Cp (see Figure 4-15); after the swap, the comparator uses up to nine sets of limits for parameter D and one set of limits for parameter Cp.

Figure 4-15

Parameter Swap Feature

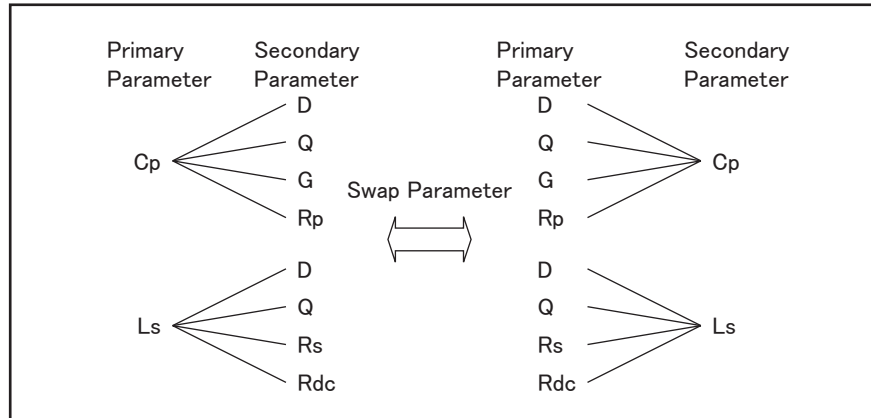

e4980aue1052

To swap the primary and secondary parameters:

- Step 1.** Press [Meas Setup].
- Step 2.** Press the **LIMIT TABLE** softkey.
- Step 3.** Using the cursor keys, select the FUNC field.
- Step 4.** Press the **SWAP PARAM** softkey to swap the primary and secondary parameters.

You can revert to the previous setting of primary and secondary parameters by pressing the **SWAP PARAM** softkey again.

NOTE

Using the parameter swap feature does not change the primary and secondary parameters for the measurement function (on the MEAS DISPLAY and MEAS SETUP pages).

Comparator Limit Mode

Functional Description

You can specify the primary parameter limit values in one of the following two ways (see Figure 4-16):

- Tolerance mode

In tolerance mode, the comparison limit values are based on the deviations from the specified nominal value, which can be specified in the NOM field. You configure the tolerance mode limit values as a deviation percentage (%) or absolute parameter value.

- Sequential mode

In sequential mode, the comparison limit values are based on the absolute value of the measurement. When you configure these limit values, you have to first define the minimum value and then the maximum value.

Figure 4-16

Tolerance mode and sequential mode

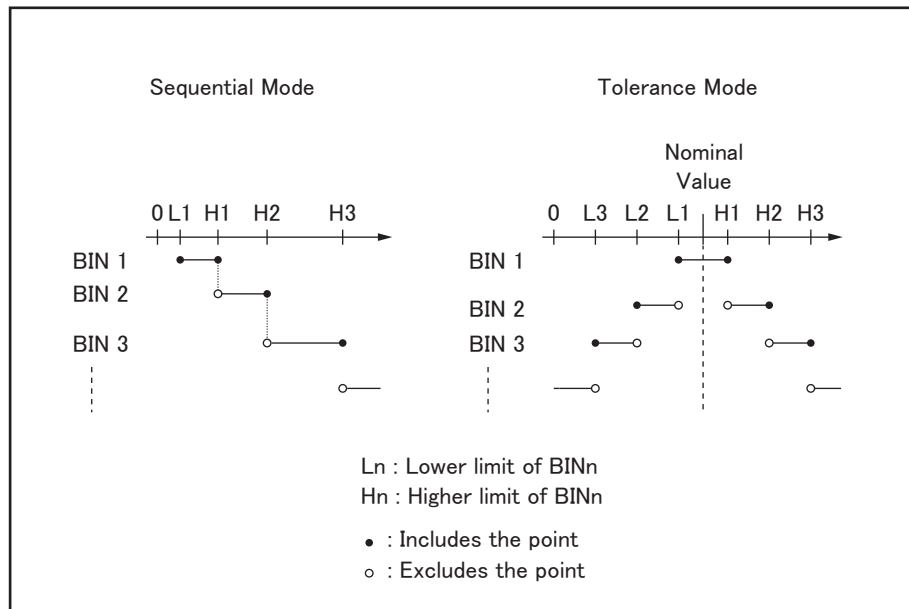

e4980aue1053

NOTE

When you use tolerance mode, you have to assign the narrowest limit value (range) to bin 1, the second narrowest range to bin2, and so on, finally assigning the widest range to the last bin. Should the range assigned to bin 1 be wider than those assigned to subsequent bins, all DUTs would be sorted into bin 1.

In tolerance mode, the lower limit need not be smaller than the nominal value, and the upper limit value need not be larger than the nominal value. As you can see in Figure 4-17, as sorting occurs, there may be blanks or overlaps.

Figure 4-17 Example of sorting in tolerance mode

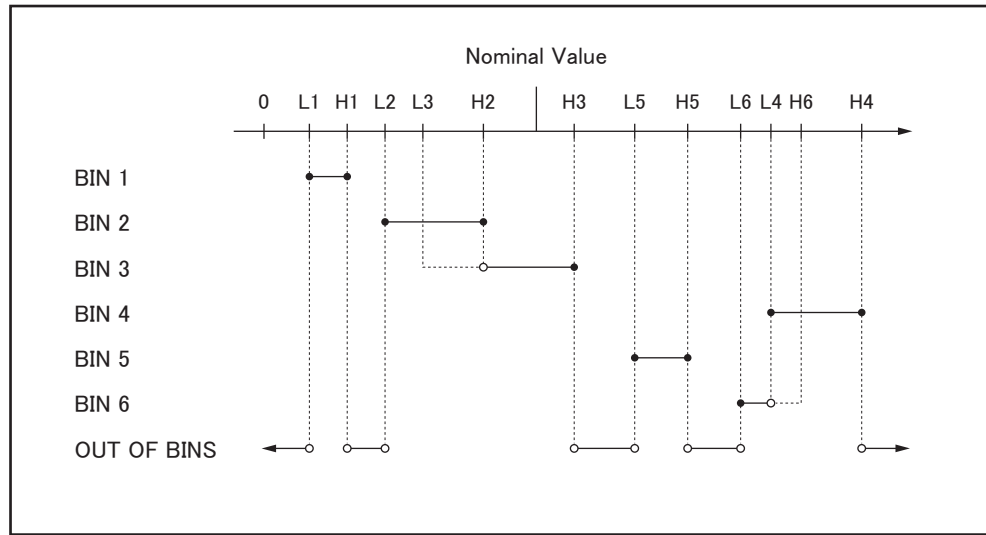

e4980aue1054

NOTE

When the limit table contains any value and you attempt to change the comparator limit mode, you are prompted with a “Clear the table first” warning message. If this is the case, clear the table and then change the limit mode. For information on how to clear the table, see “To clear the entire table:” on page 145.

To set up the comparator limit mode:

- Step 1.** Press [Meas Setup].
- Step 2.** Press the **LIMIT TABLE** softkey.
- Step 3.** Using the cursor keys, select the MODE field.
- Step 4.** Select your desired limit mode by pressing the appropriate softkey:

Softkey	Description
ABS	Switches the comparator into tolerance mode based on the absolute parameter values.
%	Switches the comparator into tolerance mode based on the deviation percentages.
SEQ	Switches the comparator into sequential mode.

Tolerance Mode Nominal Value

Functional Description

When you use tolerance mode as the limit mode for the primary parameter, you have to configure the nominal value.

The nominal value can be configured even when the primary parameter limit mode is sequential, but this does not affect sorting.

NOTE

When you use a negative nominal value in deviation tolerance mode, be sure to set the lower limit to a value higher than the upper limit because the lower limit value becomes larger than the upper limit value when they are converted into absolute values.

To configure the nominal value:

- Step 1.** Press [Meas Setup].
- Step 2.** Press the **LIMIT TABLE** softkey.
- Step 3.** Using the cursor keys, select the NOM field.
- Step 4.** Enter the nominal value using the softkeys or entry keys. If you use the entry keys to enter the value, the softkey labels change to unit labels (n, u, m, x1, k).

Softkey	Description
INCR ++	Increments the nominal value in steps of your selected number (1, 2, 5, 10, 20, 50, 100, 200, 500).
INCR +	Increments the nominal value in steps of 1.
DECR -	Decrements the nominal value in steps of 1.
DECR --	Decrements the nominal value in steps of your selected number (1, 2, 5, 10, 20, 50, 100, 200, 500).

Turning On/Off the Comparator

Functional Description

The E4980A's built-in comparator can sort DUTs into a maximum 10 levels (bin 1 through bin 9 and OUT OF BINS) using up to nine sets of primary parameter limits along with one set of secondary parameter limits.

In addition, DUTs that fall within the primary parameter limits but are out of the secondary parameter limits can be sorted into an auxiliary bin.

To turn on or off the comparator:

- Step 1.** Press [Meas Setup].
- Step 2.** Press the **LIMIT TABLE** softkey.
- Step 3.** Using the cursor keys, select the COMP field.
- Step 4.** Turn on or off the comparator by pressing the appropriate softkey:

Softkey	Description
ON	Turns ON the comparator.
OFF	Turns OFF the comparator.

Turning On/Off the Auxiliary Bin

Functional Description

If the sorting result depends on the secondary parameter, you can specify the secondary parameter limit values in the 2nd LOW/HIGH field. For sorting based on the secondary parameter, there are two scenarios:

- Sorting with the secondary parameter limit values specified and the auxiliary bin turned off:

Only those DUTs that fall within the secondary parameter values are sorted based on the result of comparing the primary parameter values. On the other hand, DUTs that do not fall within the secondary parameter limit values are sorted as OUT OF BINS, regardless of whether they fall within the primary parameter limit values.

Figure 4-18

Auxiliary bin turned off

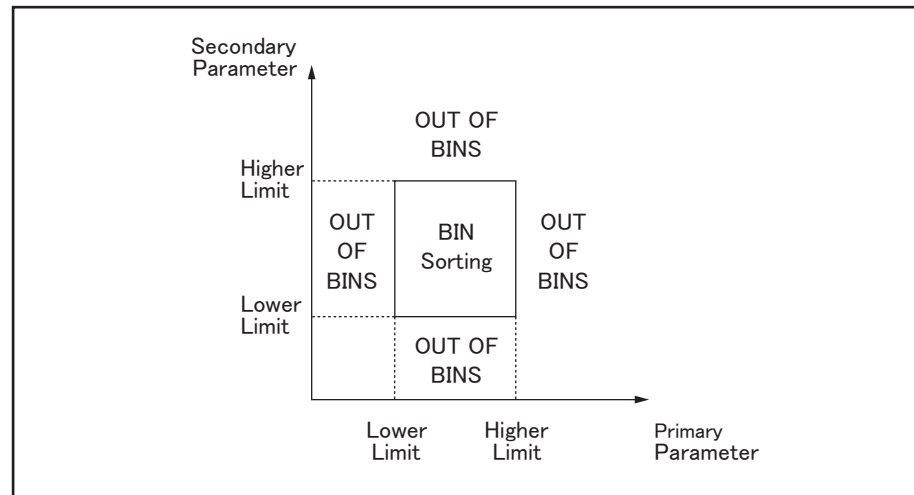

e4980aue1056

- Sorting with the secondary parameter limit values specified and the auxiliary bin turned on:

DUTs that do not fall within the primary parameter limit values are sorted as OUT OF BINS. In addition, DUTs that fall within the primary parameter limits but are out of the secondary parameter limits are sorted into the auxiliary (AUX) bin.

Figure 4-19 Auxiliary bin turned on

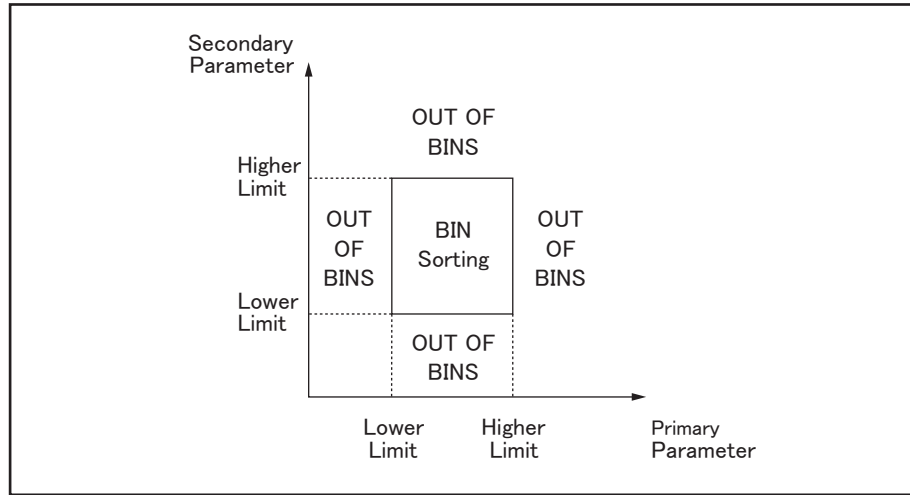

e4980aue1056

NOTE

The upper limit and lower limit of the secondary parameter after preset are set to 9.9E37 and -9.9E37, respectively.

To turn on or off the auxiliary bin:

- Step 1.** Press [Meas Setup].
- Step 2.** Press the **LIMIT TABLE** softkey.
- Step 3.** Using the cursor keys, select the AUX field.
- Step 4.** Turn on or off the auxiliary (AUX) bin by pressing the appropriate softkey:

Softkey	Description
ON	Turns ON the auxiliary (AUX) bin.
OFF	Turns OFF the auxiliary (AUX) bin.

Beep Feature

Functional Description

The beep feature of the E4980A behaves differently depending on which beep mode is in effect, as shown in Table 4-3. For more information on system beep modes, see “Turning On/Off the Beep Feature” on page 161.

The beep feature is available in the BIN COUNT DISPLAY page and LIST SWEEP DISPLAY page.

Table 4-8

Beep output conditions

System beep mode	BEEP field of limit table	Description
OFF	FAIL	Beep is never output.
	PASS	
ON	FAIL	Beep is output when the comparator sorting result is OUT OF BIN.
	PASS	Beep is output when the comparator sorting result is one of BIN1 through BIN9 or AUX BIN.

To set up the beep output conditions:

- Step 1.** Press [Meas Setup].
- Step 2.** Press the **LIMIT TABLE** softkey.
- Step 3.** Using the cursor keys, select the BEEP field.
- Step 4.** Set the beep output conditions by pressing the appropriate softkey:

Softkey	Description
FAIL	Beep is output when the comparator sorting result is OUT OF BIN.
PASS	Beep is output when the comparator sorting result is one of BIN1 through BIN9 or AUX BIN.

Lower and Upper Limits

Functional Description

The E4980A's built-in comparator can sort DUTs into a maximum 10 levels (bin 1 through bin 9 and OUT OF BINS) using up to nine sets of primary parameter limits along with one set of secondary parameter limits. Use the LOW/HIGH field for each of bins 1 through 9 to define the primary parameter lower and upper limits and the 2nd LOW/HIGH field to define the secondary parameter lower and upper limits.

When the comparator limit is set to tolerance mode, you have to set the lower limit to a value lower than the upper limit. If the lower limit is higher than the upper limit, a "Warning, Improper high/low limits" warning message appears. If you proceed without correcting the lower and upper limits, that bin's result is null and the comparator continues to the next bin to perform bin sorting.

When the comparator limit is set to sequential mode, the comparison limit values are based on the absolute value of the measurement. When you configure these limit values, you have to first define the minimum value and then the maximum value. If this rule is not followed, a "Warning, Improper high/low limits" warning message appears. If you proceed without correcting the lower and upper limits, that bin's result is null and the comparator continues to the next bin to perform bin sorting.

In sequential mode, you can omit the lower or upper limit or both for bin 1, as shown in the following examples:

- Bin 1: lower limit (L1) only
Bin 2: upper limit (H2)
Bin 3: upper limit (H3)

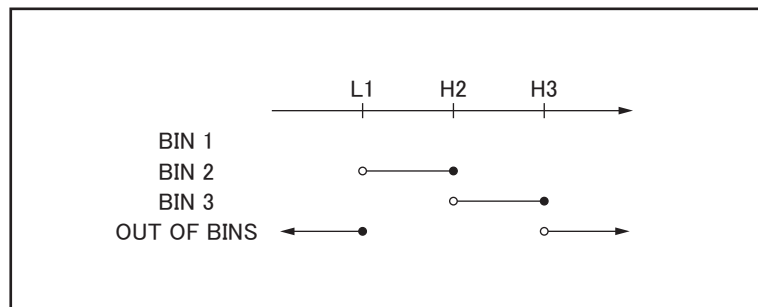

e4980auj1059

- Bin 1: upper limit (H1) only
Bin 2: upper limit (H2)

Bin 3: upper limit (H3)

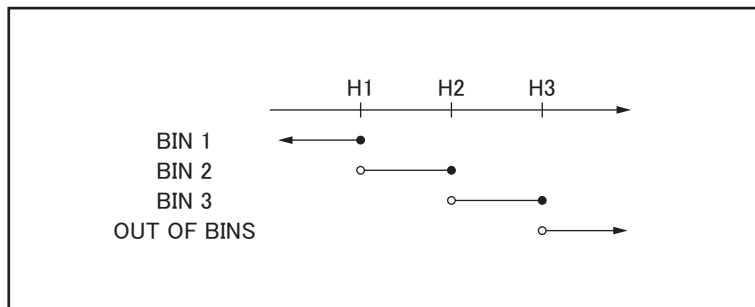

e4980auj1060

- Bin 2: upper limit (H2)
 Bin 3: upper limit (H3)

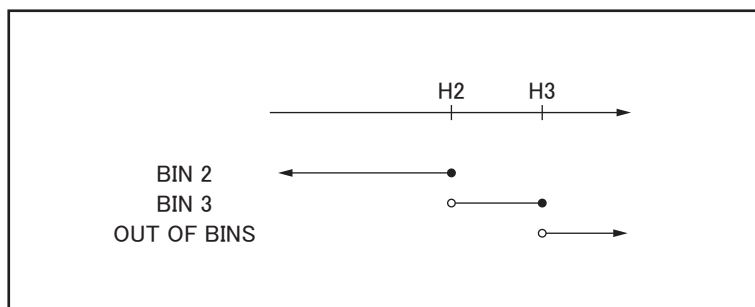

e4980auj1061

To configure the limit values for tolerance mode:

- Step 1.** Press [Meas Setup].
- Step 2.** Press the **LIMIT TABLE** softkey.
- Step 3.** Using the cursor keys, select the BIN 1 LOW field.
- Step 4.** Enter the limit value using the entry keys. When you have entered the value, the softkey labels change to unit labels (n, u, m, x1, k).^{*1}

If you want to clear your selected limit value, press the **CLEAR** softkey; also, you can clear all of the limit values for your selected bin by pressing the **CLEAR LINE** softkey.

NOTE You can enter the lower and upper limit values using the **HIGHx(-1)** or **LOWx(-1)** softkey.

- Step 5.** Repeat Step 4 using the cursor keys until you have entered the limit values for bin 9.
- Step 6.** Move the cursor into the 2nd LOW field and enter the lower limit value for the secondary parameter.
- Step 7.** Move the cursor into the 2nd HIGH field and enter the upper limit value for the secondary parameter.

*1.If the primary parameter of the measurement function is C, the softkey labels show these units: p, n, u, m, x1.

To configure the limit values for sequential mode:

- Step 1.** Press [Meas Setup].
- Step 2.** Press the **LIMIT TABLE** softkey.
- Step 3.** Using the cursor keys, select the BIN 1 LOW field.
- Step 4.** Enter the limit value using the entry keys. When you enter the value, the softkey labels change to unit labels (p, n, u, m, x1).

If you want to clear your selected limit value, press the **CLEAR** softkey; also, you can clear all the limit values for your selected bin by pressing the **CLEAR LINE** softkey.

NOTE

The LOW field accepts an entry for bin1 only and does not accept an entry for bins 2 through 9. The value entered into the HIGH field for bin 1 is used as the lower limit for bin 2, but the LOW field for bin 2 displays no value.

NOTE

You can enter the lower or upper limit values using the **HIGHx(-1)** or **LOWx(-1)** softkey.

- Step 5.** Repeat Step 4 using the cursor keys until you have entered the upper limit for bin 9 (BIN 9 HIGH).
- Step 6.** Move the cursor into the 2nd LOW field and enter the Lower limit value for the secondary parameter.
- Step 7.** Move the cursor into the 2nd HIGH field and enter the upper limit value for the secondary parameter.

To clear the entire table:

- Step 1.** Press [Meas Setup].
- Step 2.** Press the **LIMIT TABLE** softkey.
- Step 3.** Using the cursor keys, select the BIN field.
- Step 4.** Press the **CLEAR TABLE** softkey.

LIST SWEEP SETUP Page

Pressing the [Meas Setup] key followed by the **LIST SETUP** softkey opens the LIST SWEEP SETUP page. The list sweep feature of the E4980A can perform automatic sweep measurement by sweeping the frequency, signal level, DC bias, or DC source through a maximum 201 sweep points. The LIST SWEEP SETUP page allows you to configure each of the following list sweep measurement controls with the cursor placed in the corresponding field (denoted in parentheses).

- Sweep mode (MODE field)
- Sweep parameter selection (FREQ[Hz], VOLT[V], CURR[A], BIAS[V], BIAS[A], or DC SRC[V] field)
- Sweep point configuration (sweep parameter field)
- Limit parameter selection (LMT field)
- Lower and upper limits (LOW and HIGH fields)

Figure 4-20 shows the fields available on this page along with the softkeys corresponding to them.

Figure 4-20

LIST SWEEP SETUP Page

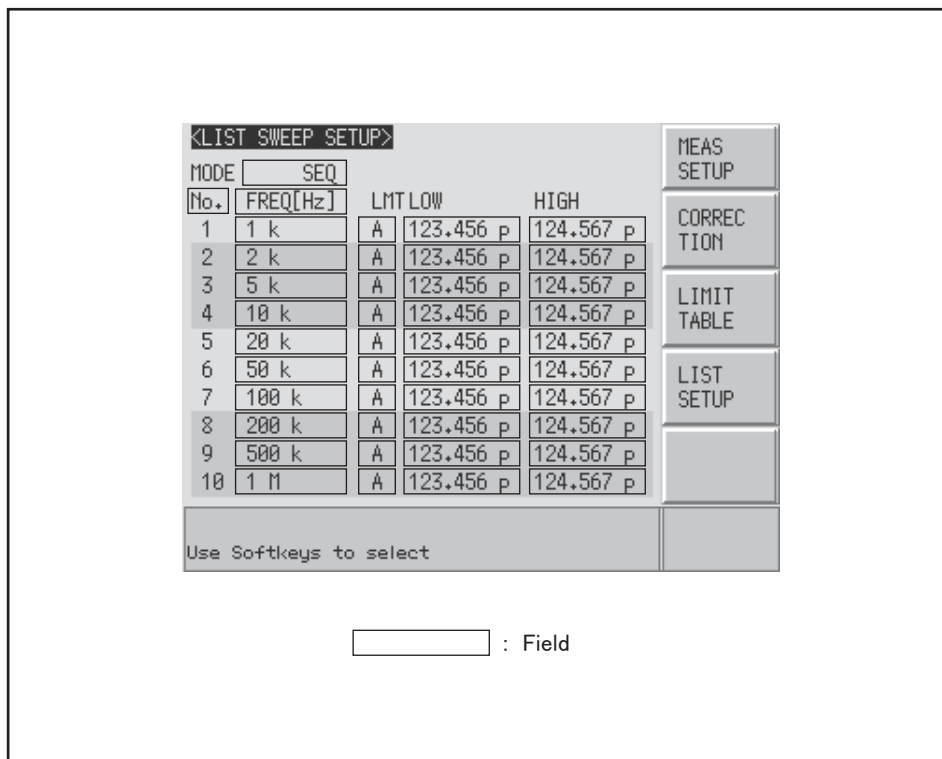

e4980aue1072

Sweep Mode

Functional Description

The list sweep feature of the E4980A can perform automatic sweep measurement by sweeping the frequency, signal level, or DC bias through a maximum 201 sweep points. The list sweep feature supports two sweep modes: sequential (SEQ) and step (STEP). In sequential mode, once the E4980A has been triggered, it performs sweep measurement throughout all the defined sweep points. In step mode, the E4980A steps to the next sweep point each time it is triggered.

Figure 4-21 Sequential and step modes

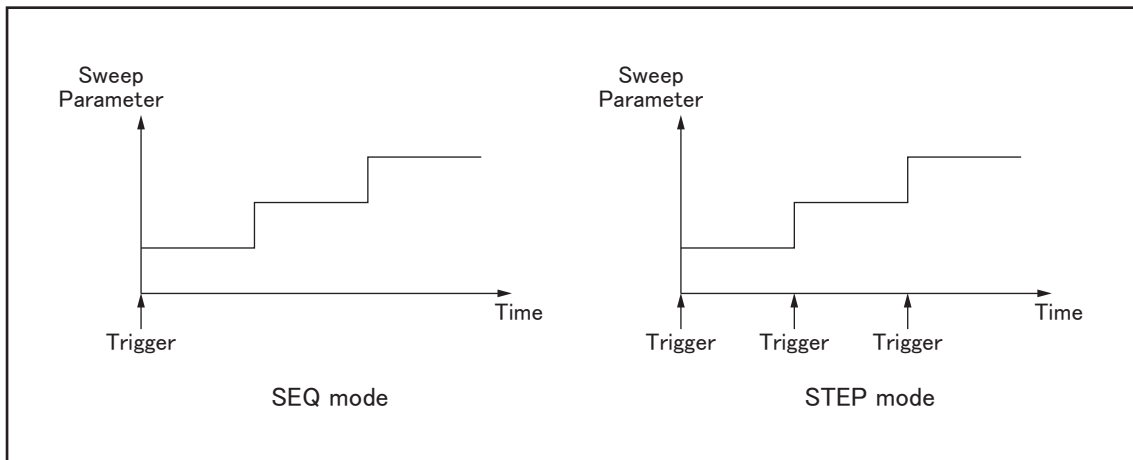

e4980aue1066

To set up the list sweep measurement mode:

- Step 1.** Press [Meas Setup].
- Step 2.** Press the **LIST SETUP** softkey.
- Step 3.** Using the cursor keys, select the MODE field.
- Step 4.** Select your desired list sweep measurement mode by pressing the appropriate softkey:

Softkey	Description
SEQ	Set the list sweep measurement mode to sequential mode.
STEP	Set the list sweep measurement mode to step mode.

List Sweep Parameters

Functional Description

The sweep parameter used in list sweep measurement can be measurement frequency, signal level, DC bias, or DC source. Use the sweep point field to specify the list sweep measurement parameter.

To specify the list sweep measurement parameter:

- Step 1.** Press [Meas Setup].
- Step 2.** Press the **LIST SETUP** softkey.
- Step 3.** Using the cursor keys, select the sweep parameter field.
- Step 4.** Select your desired list sweep measurement parameter by pressing the appropriate softkey:

Softkey	Description
FREQ [Hz]	Uses frequency as the list sweep parameter.
LEVEL [V]	Uses voltage as the list sweep parameter.
LEVEL [A]	Uses current as the list sweep parameter.
BIAS [V]	Uses DC bias voltage as the list sweep parameter.
BIAS [A]	Uses DC bias current as the list sweep parameter.
DC SRC [V]	Uses DC source as the list sweep parameter.

NOTE

When the sweep parameter is set using the SCPI commands, the secondary sweep parameter can be set. In addition, the measurement range can be set for the secondary parameter. For details, refer to “:LIST:STIMulus:TYPE” on page 321.

Sweep Points and Limit Modes

Functional Description

The list sweep measurement feature supports up to 201 sweep points as well as measurement limit values. Figure 4-22 shows the fields you can use to configure the sweep points, limit parameters, and upper and lower limit values.

Figure 4-22 Sweep point fields

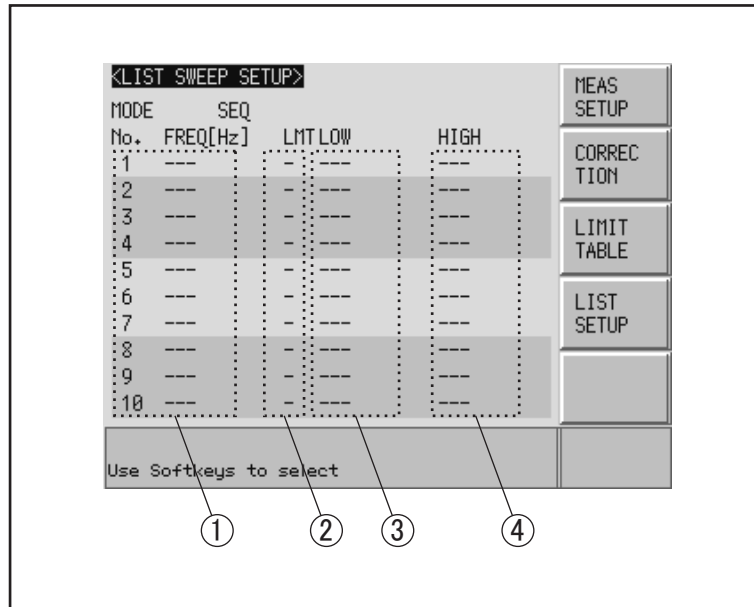

e4980auj1133

- 1 sweep points
- 2 limit parameters
- 3 lower limit values
- 4 upper limit values

NOTE If you configure only the lower limit value for a sweep point, DUTs that are below the lower limit value for the selected primary or secondary parameter are evaluated as LOW. If you configure only the upper limit value for a sweep point, DUTs that are above the upper limit value for the selected primary or secondary parameter are evaluated as HIGH.

NOTE If you specify the limit parameter for a sweep point but omit both lower and upper limit values, DUTs always pass the sweep point evaluated as IN.

NOTE Under the following conditions (unless the measurement data status is 0), DUTs are always evaluated as LOW.

- An overload is detected.
- A signal is detected exceeding the allowable limit of the signal source.

- The automatic level control (ALC) feature does not work.

NOTE

The upper limit value must be larger than the lower limit value. If this rule is not followed, a “Warning, Improper high/low limits” warning message appears, and the DUTs are evaluated as follows:

- If the result is below the lower limit, they are evaluated as LOW.
- If the result is equal to or above the lower limit, they are evaluated as HIGH.

To configure the sweep points:

- Step 1.** Press [Meas Setup].
- Step 2.** Press the **LIST SETUP** softkey.
- Step 3.** Using the cursor keys, select the sweep parameter field.
- Step 4.** Using the cursor keys, select one of the sweep point fields (1 through 201).

Also, you can use the following softkeys as needed:

Softkey	Description
CLEAR LINE	Clears the limit value.
FILL LINEAR	See “Sweep Parameter Auto-completion” on page 152.
FILL LOG	See “Sweep Parameter Auto-completion” on page 152.
NEXT PAGE	Proceeds to the next page.
PREV PAGE	Returns to the previous page.

- Step 5.** Enter the sweep point value using the entry keys. When you enter the value, the softkey labels change to unit labels (u, m, x1, k, M).
- Step 6.** Using the cursor keys, select the LMT field.
- Step 7.** Configure the limit parameter by pressing the appropriate softkey:

Softkey	Description
A	Uses the measurement function’s primary parameter as the limit parameter.
B	Uses the measurement function’s secondary parameter as the limit parameter.
-	Turns OFF the sweep point limit feature.

- Step 8.** Using the cursor keys, select the LOW field.
- Step 9.** Enter the lower limit value.
- Step 10.** Using the cursor keys, select the HIGH field.

Step 11. Enter the upper limit value.

Step 12. Repeat Step 4 to Step 11.

To clear the entire table:

Step 1. Press [Meas Setup].

Step 2. Press the **LIMIT TABLE** softkey.

Step 3. Using the cursor keys, select the No. field.

Step 4. Press the **CLEAR TABLE** softkey.

Settings of upper and lower limit value vary depending on the option

The lower limit value/upper limit value of the sweep parameters you can set vary as follows depending on the option installed in the E4980A. The options are Power/DC Bias Enhance (option 001) and Bias Current Interface (option 002).

Option 001	Installed	Installed	Not installed	Not installed
Option 002	Installed	Not installed	Installed	Not installed
FREQ[Hz]	20 - 2M	20 - 2M	20 - 2M	20 - 2M
LEVEL[V]	0 - 20	0 - 20	0 - 2	0 - 2
LEVEL[A]	0 - 100 m	0 - 100 m	0 - 20 m	0 - 20 m
BIAS[V]	-40 - 40	-40 - 40	0 - 2	0 - 2
BIAS[A]	-100 m - 40	-100 m - 100m	0 - 40	---*1
DC SRC[V]	-10 - 10	-10 - 10	---*1	---*1
IMP RNG*2	0.1 - 100 k	0.1 - 100 k	1 - 100 k	1 - 100 k

*1. An error message "DC bias opt not installed" appears.

*2. GPIB command is available.

Sweep Parameter Auto-completion

Functional Description

When you want to enter multiple sweep parameters, you can use the auto-completion feature to specify two points and have the sweep points between them automatically entered.

Figure 4-23

Sweep parameter auto-completion

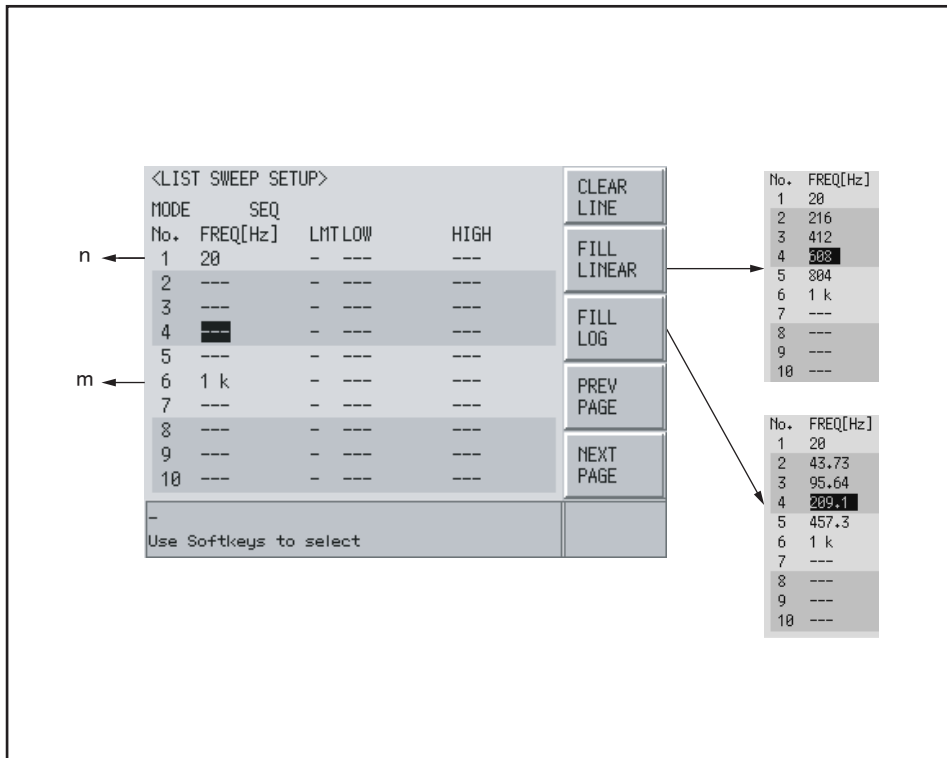

e4980auj1134

To quickly configure multiple sweep points:

- Step 1.** Press [Meas Setup].
- Step 2.** Press the **LIST SETUP** softkey.
- Step 3.** Using the cursor keys, select the sweep parameter field.
- Step 4.** Specify the start point by selecting the corresponding sweep point field (n) with the cursor keys.
- Step 5.** Specify the end point by selecting the corresponding sweep point field (m) with the cursor keys.
- Step 6.** Have all sweep points between the start and end points automatically entered by pressing

the appropriate softkey:

Softkey	Description
FILL LINEAR	Linearly enters all sweep points between the start and end points.
FILL LOG	Logarithmically enters all sweep points between the start and end points. *1

*1. Available only when using the frequency as the list sweep parameter.

NOTE

If n is not found, calculation is made on the assumption that n=1 represents the minimum value.

If m is not found, calculation is made on the assumption that m=201 represents the maximum value.

SYSTEM INFO Page

Press the [System] key to open the **SYSTEM INFO** page. This page displays the system information of the E4980A, and it allows you to configure each of the following measurement controls with the cursor placed in the corresponding field (denoted in parentheses).

- Bias current interface (CURR BIAS I/F field)
- Handler interface (HANDLER I/F field)
- Scanner interface (SCANNER I/F field)

Figure 5-1 shows the fields available on this page along with their corresponding softkeys.

Figure 5-1

SYSTEM INFO Page

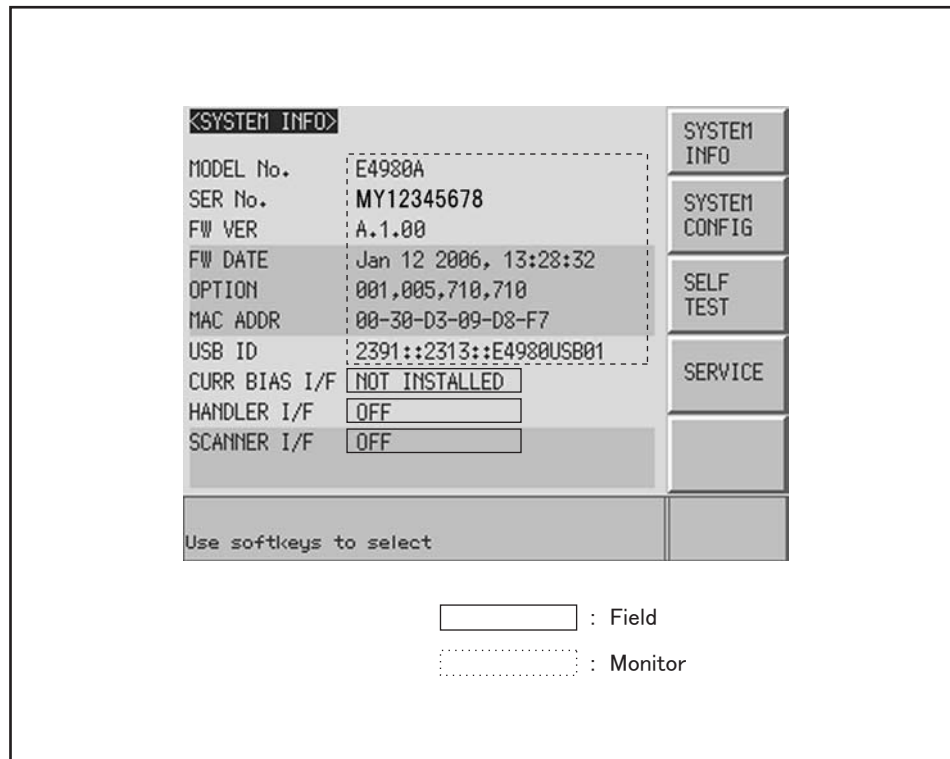

e4980aue1144

Bias Current Interface

Functional Description

When equipped with Option 002 Bias Current Interface, the E4980A can interact with the 42841A.

For more information on available options, see Appendix D , “Bias Current Interface,” on page 479 or documents that comes with the 42841A.

NOTE

When the E4980A is not equipped with the Bias Current, the CURR BIAS I/F field shows a “NOT INSTALLED” message and the ON/OFF settings are not available.

Softkey	Description
ON	Turns ON the Bias Current Interface feature.
OFF	Turns OFF the Bias Current Interface feature.

Handler Interface

Functional Description

When equipped with Option 201 Handler Interface, the E4980A can interact with the handler. The 36-contact Amphenol connector on the rear panel is used to connect the interface, through which control input/output signals and comparator bin sorting result signals are communicated.

For more information on available options, see Appendix F, “Handler Interface,” on page 511.

NOTE

When the E4980A is not equipped with the Handler Interface, the HANDLER I/F field shows a “NOT INSTALLED” message and the ON/OFF settings are not available.

Softkey	Description
ON	Turns ON the handler interface feature.
OFF	Turns OFF the handler interface feature.

Scanner Interface

Functional Description

When equipped with Option 301 Scanner Interface, the E4980A supports multi-channel correction. The 14-contact Amphenol connector on the rear panel is used to connect the interface, through which control output signals and multi-channel correction channel selector signals are communicated.

For more information on available options, see Appendix E, “Scanner Interface,” on page 487.

NOTE

When the E4980A is not equipped with the Scanner Interface, the SCANNER I/F field shows a “NOT INSTALLED” message and the ON/OFF settings are not available.

Softkey	Description
ON	Turns ON the scanner interface feature.
OFF	Turns OFF the scanner interface feature.

Monitor Information

The SYSTEM INFO page displays the following monitor information. None of this information can be edited on the SYSTEM INFO page.

Monitor Information	Description
MODEL No.	Displays the model number, i.e. E4980A.
SER No.	Displays the serial number of the instrument.
FW VER	Displays the version of the firmware installed in the instrument.
FW DATE	Displays the date of the instrument’s most recent update.
OPTION	Displays the option number of any option installed in the instrument.
MAC ADDR	Displays the MAC address.
USB ID	Displays the USB address.

SYSTEM CONFIG Page

Pressing the [System] key followed by the **SYSTEM CONFIG** softkey opens the SYSTEM CONFIG page. The SYSTEM CONFIG page displays the GPIB interface and LAN status, and it allows you to configure each of the following controls with the cursor placed in the corresponding field (denoted in parentheses).

- Beep feature ON/OFF (BEEPER ENABLED field)
- Beep tone configuration (BEEPER TONE field)
- Time zone configuration (TIME ZONE field)
- System date configuration (DATE/TIME field)
- GPIB address configuration (GPIB ADDR field)
- IP address obtaining method configuration (IP CONFIG field)
- Manual IP address configuration (MANUAL IP ADDR field)
- Subnet mask configuration (MANUAL SUBNET MASK field)
- Gateway configuration (MANUAL GATEWAY field)

In addition, this page displays the IP address, subnet mask, and gateway settings obtained by setting the IP address to AUTO.

Figure 5-2 shows the fields available on this page along with their corresponding softkeys.

Figure 5-2

SYSTEM CONFIG Page

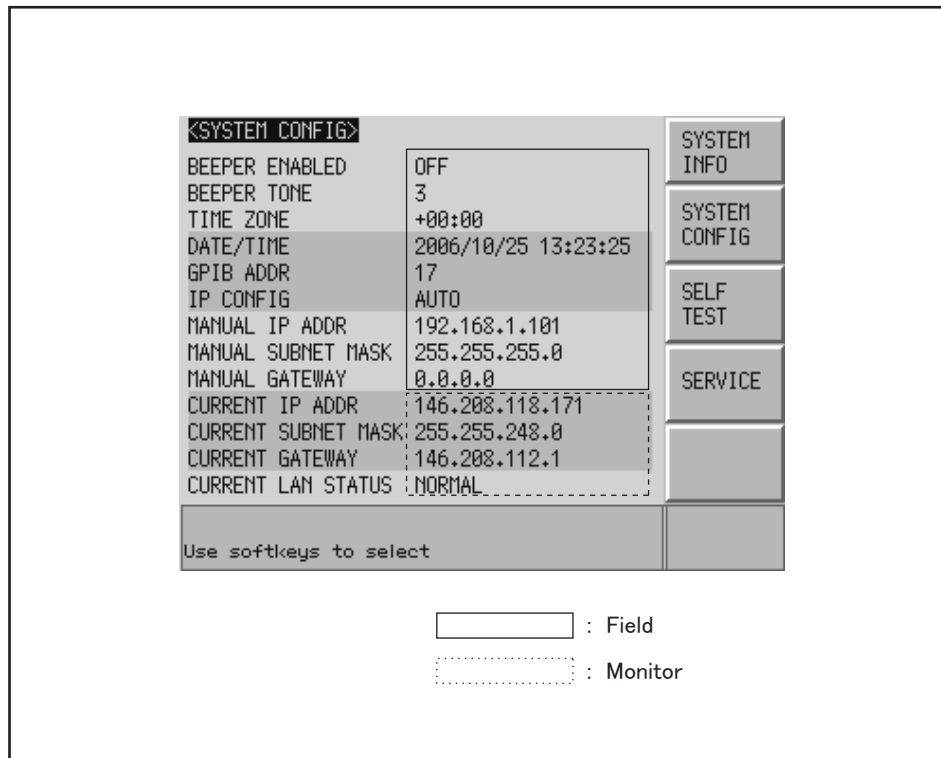

e4980aue3003

Turning On/Off the Beep Feature

Functional Description

The E4980A has a beep feature that generates beeps when one or more of the following conditions occur:

- An error message or warning message has appeared.
- The instrument has completed open/short correction.
- The instrument has completed open/short/load correction at user-specified frequency points.
- The DUT has failed the limit test or has been sorted as OUT OF BIN/AUX BIN by the comparator. ^{*1}
- The DUT has passed the limit test or has been sorted into one of bins 1 through 9 by the comparator. ^{*1}
- You have turned on/off the key lock.

Regardless of whether the beep feature is on or off, beeps are generated whenever:

- E4980A starts up.
- You change the beep tone through the front panel.

NOTE

The beep feature does not support volume control.

To set up the beep feature:

- Step 1.** Press [System].
- Step 2.** Press the **SYSTEM CONFIG** softkey.
- Step 3.** Use the cursor keys to select the BEEPER ENABLED field.
- Step 4.** Turn on or off the beep feature by pressing the appropriate softkey:

Softkey	Description
ON	Turns ON the beep feature.
OFF	Turns OFF the beep feature.

^{*1.} You can use the BEEP field on the LIST SWEEP SETUP page or the COMP:BEEP command to turn on/off the beep feature for the comparator.

Changing the Beep Tone

Functional Description

The E4980A allows you to change the beep tone to one of five levels.

To change the beep tone:

- Step 1.** Press [System].
- Step 2.** Press the **SYSTEM CONFIG** softkey.
- Step 3.** Use the cursor keys to select the BEEPER TONE field.
- Step 4.** Change the beep tone by pressing the appropriate softkey:

Softkey	Description
TONE 1	Selects tone 1.
TONE 2	Selects tone 2.
TONE 3	Selects tone 3.
TONE 4	Selects tone 4.
TONE 5	Selects tone 5.

Changing the Beep Tone

Functional Description

The E4980A allows you to change the beep tone to one of five levels.

To change the beep tone:

- Step 1.** Press [System].
- Step 2.** Press the **SYSTEM CONFIG** softkey.
- Step 3.** Use the cursor keys to select the BEEPER TONE field.
- Step 4.** Change the beep tone by pressing the appropriate softkey:

Softkey	Description
TONE 1	Selects tone 1.
TONE 2	Selects tone 2.
TONE 3	Selects tone 3.
TONE 4	Selects tone 4.
TONE 5	Selects tone 5.

Configuring the Time Zone

Functional Description

The E4980A allows you to set a time zone. “Configuring the System Date” on page 165 changes whenever the time zone is changed.

NOTE

The summer time cannot be set.

Set the time difference from Greenwich Mean Time, GMT.

To configure the time zone

Step 1. Press [System].

Step 2. Press the **SYSTEM CONFIG** softkey.

Step 3. Use the cursor keys to select the TIME ZONE field.

Step 4. Use the following softkeys:

Softkey	Description
HOURL INCR ++	Increments the time up to +15 in steps of 1.
MINUTE INCR +	When the time is plus (+), increments the time from 0 to 45 in steps of 15. When the time is minus (-), increments the time from -45 to 0 in steps of 15.
HOURL DECR --	Decrements the time to -12 in steps of 1.
MINUTE DECR -	When the time is plus (+), decrements the time from 45 to 0 in steps of 15. When the time is minus (-), decrements the time from 0 to -45 in steps of 15.

NOTE

When the E4980A is returned to the factory default settings, the time zone setting is also initialized.

Configuring the System Date

Functional Description

The E4980A features a built-in clock.

NOTE Configure the system date after “Configuring the Time Zone” on page 164.

To configure the system date:

- Step 1.** Press [System].
- Step 2.** Press the **SYSTEM CONFIG** softkey.
- Step 3.** Use the cursor keys to select the DATE/TIME field.
- Step 4.** Use the following softkeys:

Softkey	Description
DATE	Selects the date field so that you can change the year, month, and day.
TIME	Selects the time field so that you can change the hour, minute, and second digits.

- Step 5.** If you have selected the date field, use the following keys to edit the year, month, and day. If you have selected the time field, proceed to Step 7.

Softkey	Description
YEAR	Allows you to change the year digits.
MONTH	Allows you to change the month digits.
DAY	Allows you to change the day digits.

- Step 6.** Enter the year/month/day using the softkeys or entry keys. If you use the entry keys to enter the value, the softkey labels change to unit labels (x1).

Softkey	Description
YEAR INCR +	Increments the year in steps of 1.
YEAR DECR -	Decrements the year in steps of 1.
MONTH INCR +	Increments the month in steps of 1.
MONTH DECR -	Decrements the month in steps of 1.
DAY INCR +	Increments the day in steps of 1.
DAY INCR -	Decrements the day in steps of 1.

NOTE When you enter the year through the entry keys, use a four-digit value.

Step 7. If you have selected the time field, use the following keys to edit the hour, minute, and second digits.

Softkey	Description
HOUR	Allows you to change the hour digits.
MINUTE	Allows you to change the minute digits.
SECOND	Allows you to change the second digits.

Step 8. Enter the hour/minute/second digits using the softkeys or entry keys. If you use the entry keys to enter the value, the softkey labels change to unit labels (x1).

Softkey	Description
HOUR INCR +	Increments the hours in steps of 1.
HOUR DECR -	Decrements the hours in steps of 1.
MINUTE INCR +	Increments the minutes in steps of 1.
MINUTE DECR -	Decrements the minutes in steps of 1.
SECOND INCR +	Increments the seconds in steps of 1.
SECOND DECR -	Decrements the seconds in steps of 1.

NOTE

When you enter the hour with the entry keys, use a value within the range of 0 (midnight) through 23 (11:00 pm).

Configuring the GPIB Address

Functional Description

Before you can control the E4980A by issuing GPIB commands from an external controller connected via its GPIB connector, you have to configure the GPIB address of your E4980A. For information on the concept and implementation of automatic configuration by use of GPIB, see “GPIB remote control system” on page 227.

To configure the GPIB address:

- Step 1.** Press [System].
- Step 2.** Press the **SYSTEM CONFIG** softkey.
- Step 3.** Use the cursor keys to select the GPIB ADDR field.
- Step 4.** Enter a value with the entry keys in the range of 0 through 30.

Configuring the LAN IP address

Functional Description

To enable the E4980A to communicate over a local area network (LAN), you have to configure its IP address and connect a LAN cable. The IP address can be either automatically obtained or manually configured. For automatic configuration, two methods are available: DHCP and AUTO-IP.

When the IP address is set to **AUTO**, DHCP address is set at first. If DHCP fails to obtain the address, however, AUTO-IP address is set. When the IP address is set to **MANUAL**, the address manually configured is set.

For information on the concept and implementation of automatic configuration by use of a LAN, see “LAN remote control system” on page 229.

Softkey	Function
AUTO	Automatically obtains the IP address.
MANUAL	Manually configures the IP address.

Table 5-1

IP address configuration methods

Method	Description
DHCP	You can automatically obtain an available IP address via a DHCP server.
AUTO-IP	You can automatically obtain an available IP address within the range of 169.254.xxx.xxx.
MANUAL	You can manually configure the IP address as well as subnet mask and gateway settings. *1

*1. Consult your network administrator for relevant settings of your network.

Once you have automatically obtained an IP address, you can check the following monitor areas in the SYSTEM CONFIG page to see the address, subnet mask, and gateway:

- CURRENT IP ADDR
- CURRENT SUBNET MASK
- CURRENT GATEWAY

To automatically obtain the IP address:

- Step 1.** Press [System].
- Step 2.** Press the **SYSTEM CONFIG** softkey.
- Step 3.** When you want to obtain the IP address automatically, select the IP CONFIG field using the cursor keys and then press the **AUTO** softkey.

To manually configure the IP address:

- Step 1.** Press [System].
- Step 2.** Press the **SYSTEM CONFIG** softkey.
- Step 3.** Use the cursor keys to select the IP CONFIG field and then press the **MANUAL** softkey.
- Step 4.** Use the cursor keys to select the MANUAL IP ADDR field.
- Step 5.** Enter the IP address using the entry keys.
 Example: 192.168.10.1
- Step 6.** Press the **ENTER** softkey.
- Step 7.** Use the cursor keys to select the MANUAL SUBNET MASK field.
- Step 8.** Enter the subnet mask using the entry keys.
- Step 9.** Press the **ENTER** softkey.
- Step 10.** Use the cursor keys to select the MANUAL GATEWAY field.
- Step 11.** Enter the gateway using the entry keys.
- Step 12.** Press the **ENTER** softkey.
- Step 13.** Press the **RESTART NETWORK** softkey.

Checking the LAN connection status

You can check the CURRECT LAN STATUS monitor area to see the LAN connection status of the E4980A. The status is expressed as one of the following:

表 5-2

LAN connection status

Status	Description
NORMAL	LAN connection is OK.
FAULT	Disconnected from the LAN or LAN connection has failed.
---	LAN connection is being initialized.

To reconnect to the network:

- Step 1.** Press [System].
- Step 2.** Press the **SYSTEM CONFIG** softkey.
- Step 3.** Press the **RESTART NETWORK** softkey on the IP CONFIG field, MANUAL IP ADDR field, MANUAL SUBNET MASK field, or MANUAL GATEWAY field.

SELF TEST Page

Pressing the [System] key followed by the **SELF TEST** softkey opens the SELF TEST page. The SELF TEST page, intended for maintenance and repair, allows you to check the behavior of the E4980A. You can choose one of available test items with the cursor placed in the corresponding field (denoted in parentheses).

- Choosing a Test Item (TEST No. field)

Figure 5-3 shows the fields available on this page along with their corresponding softkeys.

Figure 5-3

SELF TEST Page

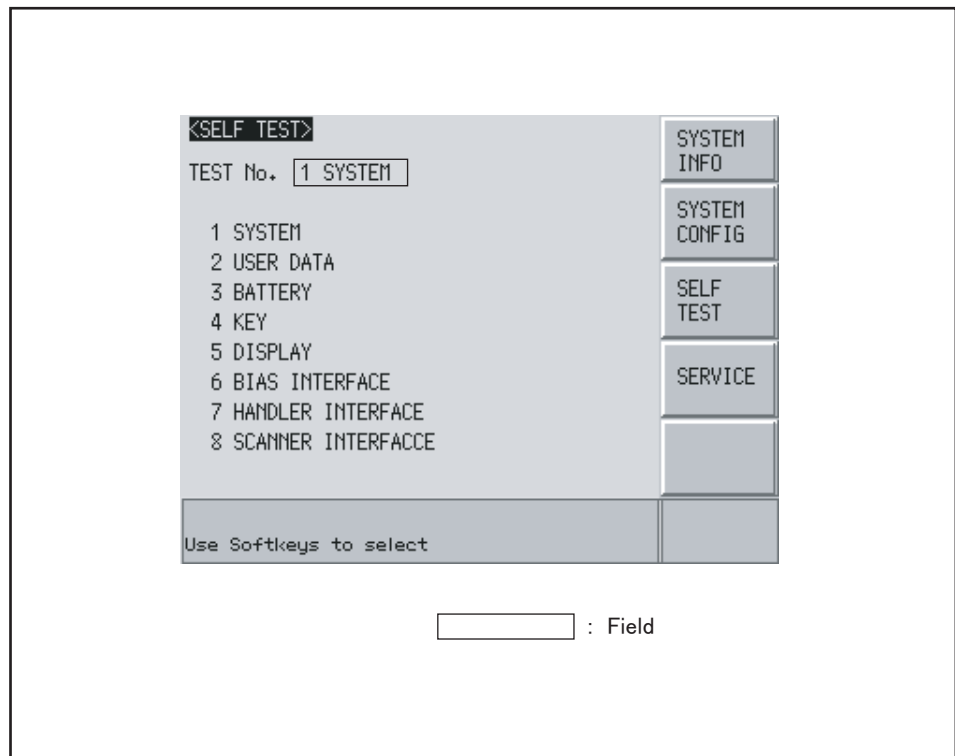

e4980aue1146

Choosing a Test Item

Functional Description

The E4980A can run the following self tests:

Table 5-3

Test item	Description
SYSTEM	Checks the entire system, A1/A2/A3 boards, system calibration data, and so on.
USER DATA	Checks the GPIB/LAN configurations, instrument configuration information, instrument calibration data, and scanner calibration data.
BATTERY	Checks the internal batteries.
KEY	Checks the front panel keys. (Visual confirmation only; no pass/fail result shown on screen.)
DISPLAY	Checks the front panel LEDs and LCD. (Visual confirmation only; no pass/fail result shown on screen.)
BIAS INTERFACE	Checks the bias interface. (Visual confirmation only; no pass/fail result shown on screen.)
HANDLER INTERFACE	Checks the handler interface. (Visual confirmation only; no pass/fail result shown on screen.)
SCANNER INTERFACE	Checks the scanner interface. (Visual confirmation only; no pass/fail result shown on screen.)

To run a self test:

For step-by-step instructions, see “Daily Checks (Executing the self-test)” on page 449.

SERVICE Page

Pressing the [System] key followed by the **SERVICE** softkey opens the SERVICE page.

This page is read-only.

This page displays the system information of the E4980A and allows you to save the displayed information into USB memory, but it does NOT allow you to modify or delete the information.

NOTE

The system information of the E4980A may be used for support and repair by Agilent Technologies but will never be used for any other purpose.

Figure 5-4

SELF TEST Page

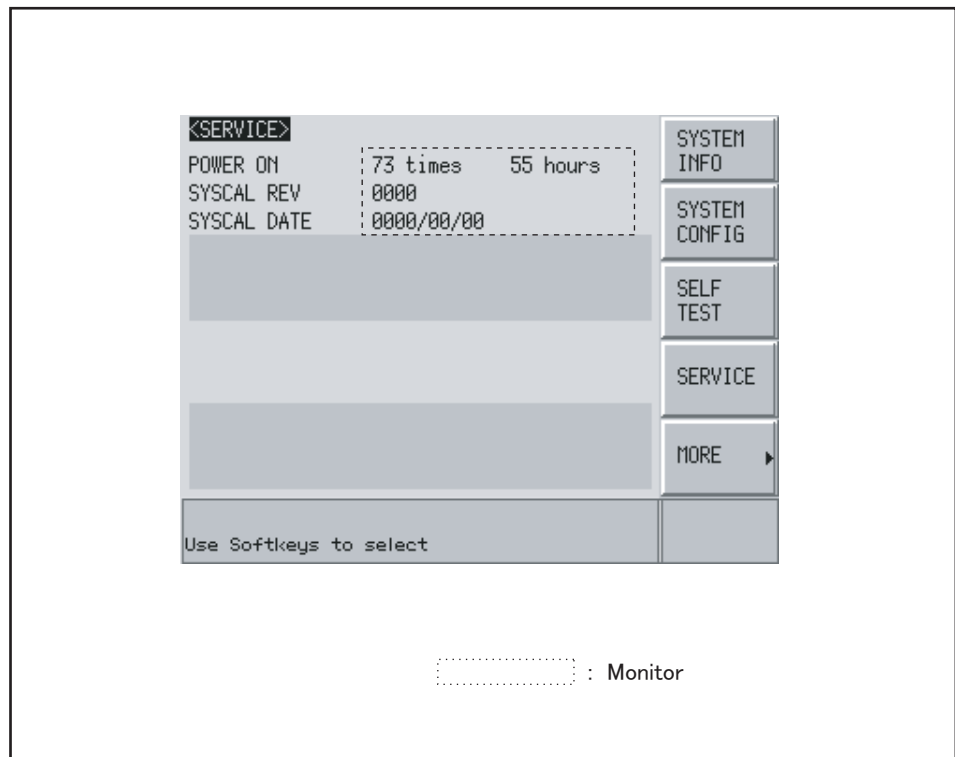

e4980aue1147

Monitor Information

The SERVICE page displays the following monitor information, which cannot be edited on the SERVICE page.

Monitor Information	Description
POWER ON	Displays how many times the E4980A has been started up as well as its cumulative power-on time.
SYSCAL REV	Displays the program revision of the adjustment for the E4980A.
SYSCAL DATE	Displays the date of the last adjustment for the E4980A.

Saving the System Information into External Memory

The system information of the E4980A can be saved into external memory.

The system information may be useful for support and repair by Agilent Technologies. For details on the system information, refer to the Service Guide.

For file locations on USB memory, see “Folder/File Structure on USB Memory” on page 176.

NOTE

The system information of the E4980A may be used for support and repair by Agilent Technologies but will never be used for any other purpose.

To save the system information into external memory:

- Step 1.** Insert a USB memory stick into the front USB port.
- Step 2.** Press [System].
- Step 3.** Press the **SERVICE** softkey.
- Step 4.** Press the **MORE** softkey.
- Step 5.** Press the **SAVE SYS INFO** softkey.
- Step 6.** While the data is being saved, a “PROCESSING..” message is shown on the display. When the data has been saved into the USB memory, a “Storing data completed.” message appears in the system message area.

6 **Save/Recall**

This chapter provides information on the save/recall functionality of the E4980A.

Overview of Save/Recall Functionality

Configurations and measurement results can be saved into, and recalled from, the E4980A's internal memory or external USB memory through the save/recall functionality.

Save Methods and Their Uses

Table 6-1 shows available save methods and their uses:

Table 6-1 Save Methods and Their Uses

Save method		Recallable	Use
Type	File format (extension)		
Configuration Save (internal memory)	-----	Yes	To save E4980A's configuration states into the internal memory.
Configuration Save (USB memory)	(.sta)	Yes	To save E4980A's configuration states into USB memory.
Data Save (USB memory)	CSV format (.csv)	No	To save measurement results into USB memory.
Screen Save (USB memory)	GIF format (.gif)	No	To save E4980A's screenshot into USB memory.

NOTE

For information on configuration states that can be saved, see Appendix C, "List of Default Values," on page 473.

Folder/File Structure on USB Memory

When you save information into USB memory, a predetermined structure scheme is used to organize folders and files on the memory, as shown in Figure 6-1.

Folder	Max. number of files	Description
data	999	Contains measurement results as .csv files.
image	999	Contains screenshots as .gif files.
state	10	Contains instrument configuration states.
system ^{*1}	1	This single file, whose name is always "system," contains the system information.

*1. This folder can be operated from the SYSTEM page.

NOTE

These folders are automatically created in the memory.

Figure 6-1

Folder/File Structure on USB Memory

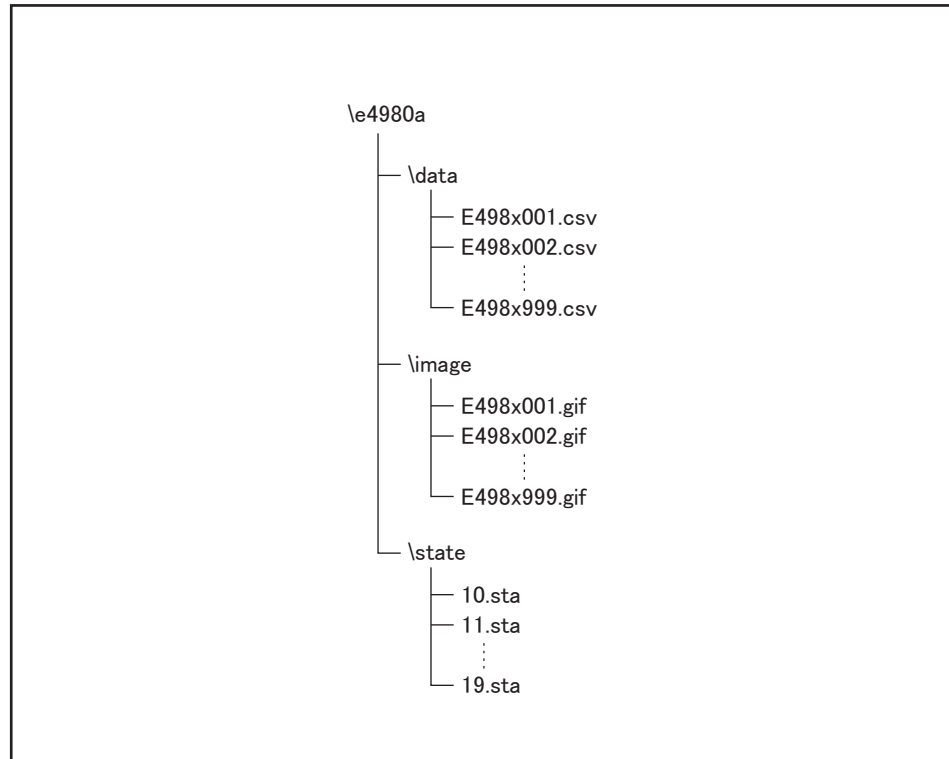

e4980auj1148

USB Memory Notes

Attention should be given to the following points when using a USB memory device with the E4980A

- Use a USB memory whose interface is USB 1.1.
- Use a USB memory that is USB mass storage class compliant and formatted with FAT16 or FAT32.
- Use the USB memory solely for the E4980A. Otherwise, other data previously saved in the USB memory could be erased.
- If you cannot save into or recall from the USB memory, use another USB memory device.
- Agilent Technologies shall not be responsible for nor assume any liability for data loss in your USB memory device after using it with the E4980A.

Saving/Recalling Instrument Configuration States

Overview of Instrument Configurations

Pressing the [Save/Recall] opens the CATALOG page. You can save/recall instrument configuration states in either of two ways:

- Save into the internal memory
- Save into USB memory

You can save up to 10 registers into the internal memory and into a single USB memory device. Also, register numbers have extensions as shown in Table 6-2:

Table 6-2

Extensions for register numbers

Classification	Register number (No. field)	Extension
Internal memory	0	Recalled when the [Recall A] key is pressed.
	1	Recalled when the [Recall B] key is pressed.
	2 through 9	-
USB memory	10	Auto recall
	11 through 19	-

In this page, you can configure each of the following controls with the cursor placed in the corresponding field (denoted in parentheses).

- Medium mode (MEDIA field)
- Register number (No. field)

Figure 6-2

CATALOG page

No.	S	COMMENT
0	1	Cp-D Meas
1	0	
2	1	Device A
3	1	Device B
4	0	
5	0	
6	0	
7	0	
8	0	
9	0	

Use Softkeys to select

: Field
 : Monitor

e4980aue1140

Medium Mode

Functional Description

You have to specify the medium type of the destination or source before saving or recalling instrument configurations.

To select the medium mode:

- Step 1.** Press [Save/Recall].
- Step 2.** Use the cursor keys to select the MEDIA field.
- Step 3.** Select the medium mode by pressing the appropriate softkey:

Softkey	Description
INT	Uses the internal memory as the destination or source. Once you have selected this mode, the register numbers (in the No. field) change to 0 through 9.
EXT	Uses USB memory as the destination or source. Once you have selected this mode, the register numbers (in the No. field) change to 10 through 19.

Choosing a Register Number

Functional Description

You have to choose one of the register numbers (in the No. field) before saving or recalling instrument configurations.

Available choices include 0 through 9 when the medium mode is INT (internal memory), or 10 through 19 when the medium mode is EXT (USB memory).

To choose a register number and save/recall the configurations:

- Step 1.** Press [Save/Recall].
- Step 2.** Use the cursor keys to select the No. field of your desired register number.
- Step 3.** Select your desired action by pressing the appropriate softkey:

Softkey	Description
RECALL	Recalls the configurations previously saved in the register that corresponds to your specified register number.
SAVE	Saves the configurations into the register that corresponds to your specified register number.
DELETE	Deletes the configurations previously saved in the register that corresponds to your specified register number.

Memory Status Information

Functional Description

Each register number is associated with one of the following memory status values:

Status value	Description
-1	The register contains non-E4980A configuration information. *1
0	The register contains no configurations.
1	The register does contain configurations.
2	The register contains any configuration that was saved under a different firmware version or from another E4980A with a different option(s) equipped. *2

*1. This value is not applicable when the medium mode is INT (internal memory).

*2. An "Incompatible state file" warning message is displayed. Status information may fail to be correctly recalled.

Comment Information

Functional Description

You can view comments entered into the comment line (USER COMMENT field) on the Measurement Conditions screen. For information on how to enter a comment, see “Comment line” on page 93.

Saving/Recalling Instrument Configuration States into/from the Internal Memory

Figure 6-3 shows the fields available on this page along with the softkeys corresponding to them.

Figure 6-3

CATALOG page (when saving instrument configurations into the internal memory)

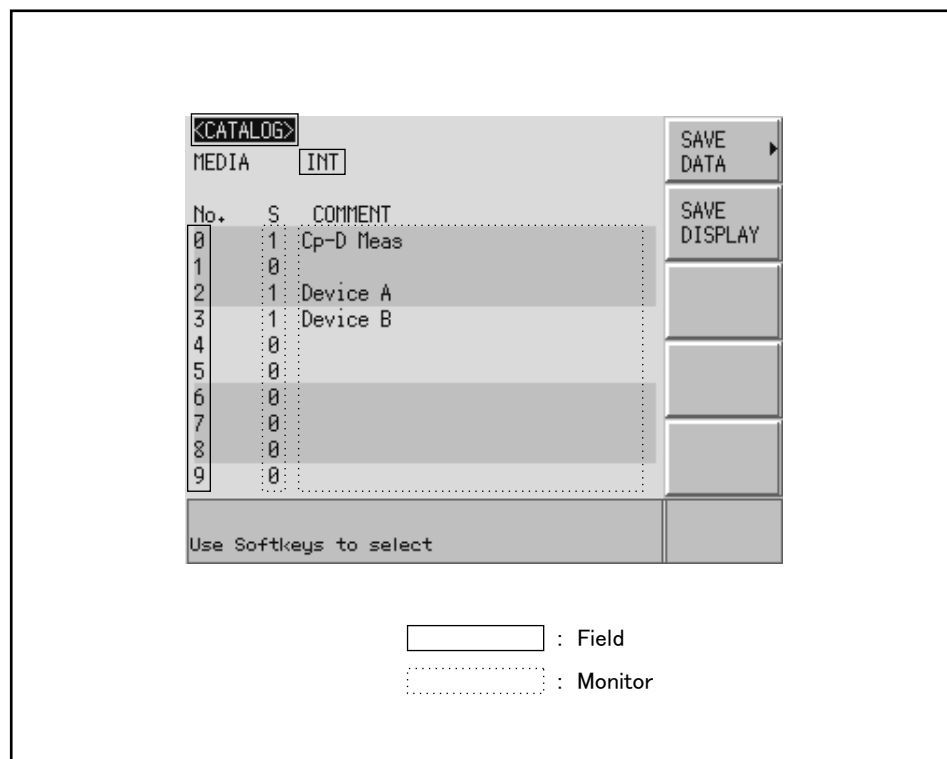

e4980aue1140

To save configuration states into the internal memory:

- Step 1.** Press [Save/Recall].
- Step 2.** Use the cursor keys to select the MEDIA field.
- Step 3.** Press the **INT** softkey.
- Step 4.** Use the cursor keys to select the No. field (0 through 9) for your desired register.
- Step 5.** Press the **SAVE** softkey to save configuration states into the internal memory.

Save/Recall

Saving/Recalling Instrument Configuration States

NOTE If you have selected the No. field for a register that already contains configuration states, new configuration states overwrite the existing ones.

To recall configuration states from the internal memory:

- Step 1.** Press [Save/Recall].
- Step 2.** Use the cursor keys to select the MEDIA field.
- Step 3.** Press the **INT** softkey.
- Step 4.** Use the cursor keys to select the No. field (0 through 9) for your desired register.
- Step 5.** Press the **RECALL** softkey to recall configurations from the internal memory.

NOTE DC bias and DC source settings are automatically turned OFF.

If you attempt to recall configuration states under any of the following conditions, an “Incompatible state file” warning message is displayed.

- The configuration states were saved under a different firmware version.
- The configuration states were saved from another E4980A with a different option(s) equipped.

If you attempt to recall configuration states under the following condition, a “No data to load” error message is displayed.

- The checksum has failed.

Using a Hard Key to Recall States from the Internal Memory

You can also recall configuration states from a particular register in the internal memory by pressing one of the following hard keys:

Hard key	Description
Recall A	Recalls configuration states from register 0 (#0 in the No. field).
Recall B	Recalls configuration states from register 1 (#1 in the No. field).

Saving/Recalling Instrument Configuration States into/from USB Memory

Figure 6-4 shows the fields available on this page along with the softkeys corresponding to them.

Figure 6-4

CATALOG page (when saving instrument configurations into USB memory)

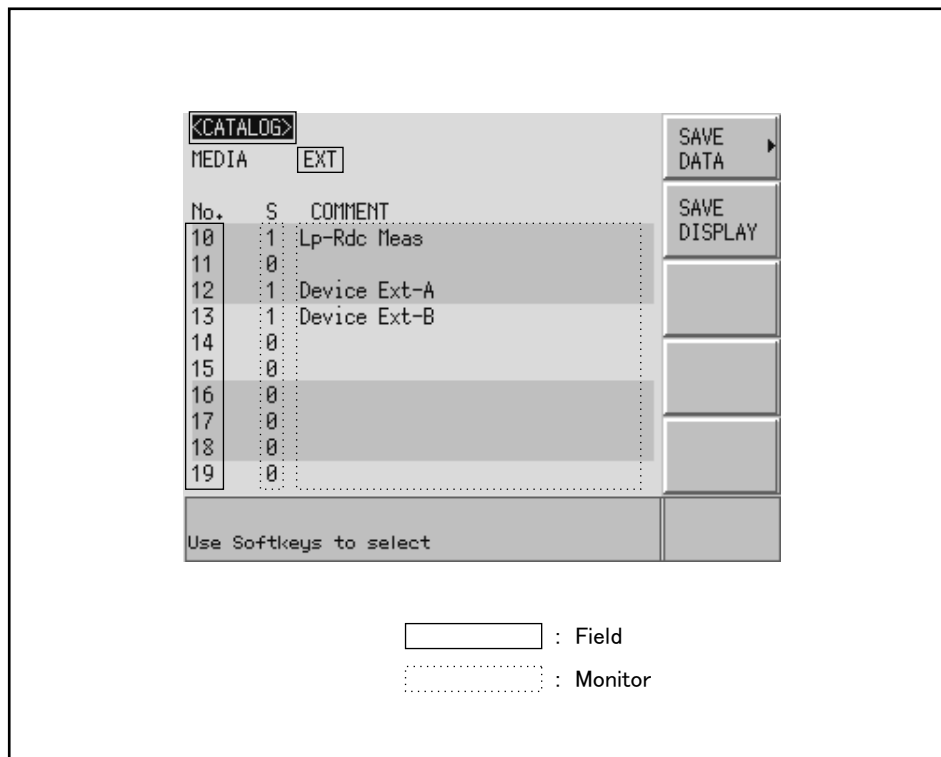

e4980aue1141

Functional Description

When you save configuration states into USB memory, they are saved as predefined files in predefined locations. You cannot manually define the file names or locations.

Each state file is assigned a file name in the format of “register number.sta”.

To save configuration states into USB memory:

- Step 1.** Press [Save/Recall].
- Step 2.** Use the cursor keys to select the MEDIA field.
- Step 3.** Press the **EXT** softkey.
- Step 4.** Use the cursor keys to select the No. field (10 through 19) for your desired register.
- Step 5.** Press the **SAVE** softkey to save configuration states into the USB memory.

NOTE

If you have selected the No. field for a register that already contains configuration states, the new configuration states overwrite the existing ones.

Save/Recall
Saving/Recalling Instrument Configuration States

To recall configuration states from USB memory:

- Step 1.** Press [Save/Recall].
- Step 2.** Use the cursor keys to select the MEDIA field.
- Step 3.** Press the **EXT** softkey.
- Step 4.** Use the cursor keys to select the No. field (10 through 19) for your desired register.
- Step 5.** Press the **RECALL** softkey to recall configurations from the USB memory.

NOTE State files are automatically assigned file names 10.sta through 19.sta, and you cannot change the file names.

If you attempt to recall configuration states under any of the following conditions, an “Incompatible state file” warning message is displayed.

- The configuration states were saved under a different firmware version.
- The configuration states were saved from another E4980A with a different option(s) equipped.

NOTE DC bias and DC source settings are automatically turned OFF.

If you attempt to recall configuration states under the following condition, a “No data to load” error message is displayed.

- The checksum has changed.

Using the Auto Recall Feature

Functional Description

You can have the E4980A, at start-up time, automatically recall the configuration states previously saved in register number 10 on USB memory. To use this feature, you have to plug the appropriate USB memory into the E4980A before starting up.

To use the auto recall feature:

- Step 1.** Plug the appropriate USB memory into the E4980A.
- Step 2.** Turn on the power to the E4980A.
- Step 3.** Upon start-up, the instrument configures itself using the instrument configuration information previously saved in register number 10 on the USB memory device.

Saving Measurement Results into USB Memory

You can save measurement results obtained by the E4980A into USB memory as .CSV files. You can later load your saved files into an application program running on a PC.

You can save up to 201 sets of measurement results at a time, including measurement results from a list sweep.

Before saving measurement results into USB memory, you need to complete some tasks preparatory to initiating measurement so that the data buffer memory contains the necessary data. For more information, see “To save measurement results into USB memory:” on page 189.

NOTE You cannot obtain measurement results that come after your specified value from the data buffer memory. However, you can set up the data buffer memory using the “:MEMory:DIM” on page 323 command.

NOTE You cannot load measurement results from USB memory into the E4980A.

Measurement Result Format

Measurement results are output in the format shown in Table 6-3.

The Data A and Data B fields of a measurement result file differ depending on whether the “effective digits” setting is on or off (controlled by the :FORM:ASC:LONG command).

Table 6-3

Measurement Result Format

Measure ment Screen	Comparator	Result Format
one point	OFF	<Data A>,<Data B>,<Status>
one point	ON	<Data A>,<Data B>,<Status>,<BIN No.>
list	ON/OFF	<Data A>,<Data B>,<Status>,<IN/OUT>

Data A

Outputs the measurement data for the primary parameter.

The Data A field uses the following two different fixed-length ASCII formats:

When the “effective digits” setting is off:
 SN.NNNNNNESNN
 (S:+/-, N:0 to 9, E: exponent character)
 (:FORM:ASC:LONG OFF)

When the “effective digits” setting is on:
 SN.NNNNNNNNNNESNN
 (S:+/-, N:0 to 9, E: exponent character)
 (:FORM:ASC:LONG ON)

Data B

Outputs the measurement data for the secondary parameter.

The Data B field uses the following two different fixed-length ASCII formats:

When the “effective digits”
setting is off: SN.NNNNNNESNN
(S:+/-, N:0 to 9, E: exponent character)
:FORM:ASC:LONG OFF

When the “effective digits”
setting is on: SN.NNNNNNNNNNESNN
(S:+/-, N:0 to 9, E: exponent character)
:FORM:ASC:LONG ON

Status

Represents the measurement result status by using one of the following status values:

0 Measurement successfully completed.
+1 Overload.
+3 A signal is detected exceeding the allowable limit of the
signal source.
+4 The automatic level control (ALC) feature does not work.

The Status field uses the following two-character fixed-length ASCII format:

SN (S:+/-, N:0 to 4)

NOTE If the value is 1, the measurement data is 9.9E37; if the value is 0, 3, or 4, the actual measurement data is output.

NOTE The data buffer memory contains a measurement result with no data (as represented by the status value of -1), but it is excluded when the data is saved into USB memory.

Bin No. (IN/OUT)

Represents the bin sorting results as well as IN/OUT evaluation results in list sweep measurement, as shown below:

0 OUT_OF_BINS
+1 to +9 BIN 1 through BIN 9
+10 AUX_BIN

-1 LOW
0 IN
+1 HIGH

Save/Recall

Saving Measurement Results into USB Memory

The <BIN No.> data output format is either 2- or 3-character fixed-length ASCII format:

SN or SNN (S: +/-, N: 0 to 9)

Example of measurement result output

Example 6-1

Example of saved measurement result data

```
+1.059517689E-24,+1.954963777E+00,+0,+0  
+9.706803904E-25,+2.095857894E-01,+0,+0  
+2.172725184E-24,+2.072965495E-01,+0,+0  
+3.660460872E-25,+7.172688291E+00,+0,+0  
+1.135428381E-24,+6.490636201E-01,+0,+0  
+1.384790632E-24,+2.193020669E+00,+0,+0  
+3.829879310E-26,+2.788435221E+01,+0,+0
```

To save measurement results into USB memory:

For how to save the measurement result, refer to “How to save the measurement result of List Sweep Measurement to USB memory.” on page 190.

- Step 1.** Plug a USB memory stick into the front USB port.
- Step 2.** Press [Save/Recall].
- Step 3.** Press the **SAVE DATA** softkey.
- Step 4.** Press the **START LOG** softkey and then press the following softkeys to enter the measurement results into the data buffer memory.

Softkey	Description
START LOG	Starts logging the measurement results into the data buffer memory.
SAVE & STOP	Copies the data from the data buffer memory into the USB memory. Then stops saving the measurement results into the data buffer memory and clears the data buffer memory.

- Step 5.** Start measurement. The data buffer memory is filled with up to 201 sets of measurement results.
- Step 6.** Press the **SAVE & STOP** softkey to save results into the USB memory.
- Step 7.** When the data has been saved into the USB memory, a “Storing data completed. : E498xXXX.csv” message appears in the system message area.

Figure 6-5

Saving measurement results into USB memory

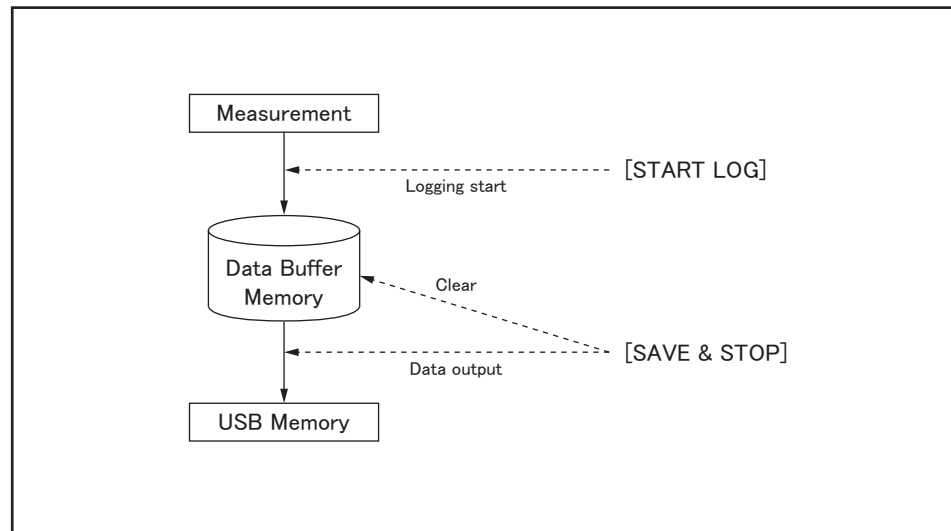

e4980aue1150

NOTE Measurement result files are automatically assigned file names E498x001.csv through E498x999.csv, and you cannot change the file names.

NOTE If the total size of the measurement result data exceeds the capacity of the data buffer

memory, a “Data Buffer Overflow” error message is displayed. If this happens, press the **SAVE & STOP** softkey.

How to save the measurement result of List Sweep Measurement to USB memory.

- Step 1.** Set the List Sweep. For the setting, refer to the “LIST SWEEP SETUP Page” on page 146.
- Step 2.** Press [Meas Setup].
- Step 3.** Using the cursor key, select the TRIG field.
- Step 4.** Set the trigger mode to (MAN).
- Step 5.** Set the USB memory to the Front USB Port.
- Step 6.** Press [Save/Recall].
- Step 7.** Press soft key **SAVE DATA**.
- Step 8.** Press soft key **START LOG**, then set the mode to accumulate the measurement result to the data buffer memory.
- Step 9.** Press [Display Format].
- Step 10.** Press soft key **LIST SWEEP**.
- Step 11.** Press [Trigger], then measure once.
- Step 12.** Press [Save/Recall].
- Step 13.** Press soft key **SAVE DATA**.
- Step 14.** Press soft key **SAVE & STOP**, then save to USB memory.
- Step 15.** When you complete the saving at USB memory, the message “Storing data completed. : E498xXXX.csv” appears at system message area.

For example, when measurement point of List Sweep is 100, 100 measurement results are saved to USB memory.

NOTE

Measurement result files are automatically assigned file names E498x001.csv through E498x999.csv, and you cannot change the file names.

Saving a Screenshot into USB Memory

You can save a screenshot of the E4980A's display into USB memory as a .GIF file. You can later load your saved file into an application program running on a PC.

To save a screenshot into USB memory

- Step 1.** Display the screen you want to save.
- Step 2.** Plug a USB memory device into the front USB port.
- Step 3.** Press [Save/Recall].
- Step 4.** Press the **SAVE DISPLAY** softkey.
- Step 5.** When the data has been saved into the USB memory device, a “Storing image completed. : E498xXXX.gif” message appears in the system message area.

NOTE

Screenshot files are automatically assigned file names E498x001.gif through E498x999.gif, and you cannot change the file names.

Save/Recall
Saving a Screenshot into USB Memory

7**Measurement Procedure and Examples**

This chapter covers basic measurement procedures as well as basic L, C, and R measurement theory. It also offers various measurement hints. After the descriptions of basic measurement procedures, practical measurement examples are shown using the E4980A.

Basic Measurement Procedure

The following flow chart shows the basic procedures used to measure the impedance of capacitors, inductors, resistors, and other components. Follow the procedures to perform impedance measurements while referring to the items noted to the right side of each step.

NOTE

For basic measurements, refer to the Impedance Measurement Handbook. For the fixtures that can be used, refer to the Accessories Selection Guide For Impedance Measurements. These documents can be downloaded from this URL:

<http://www.agilent.com/find/lcmmeters/>

Figure 7-1

Basic Measurement Procedure

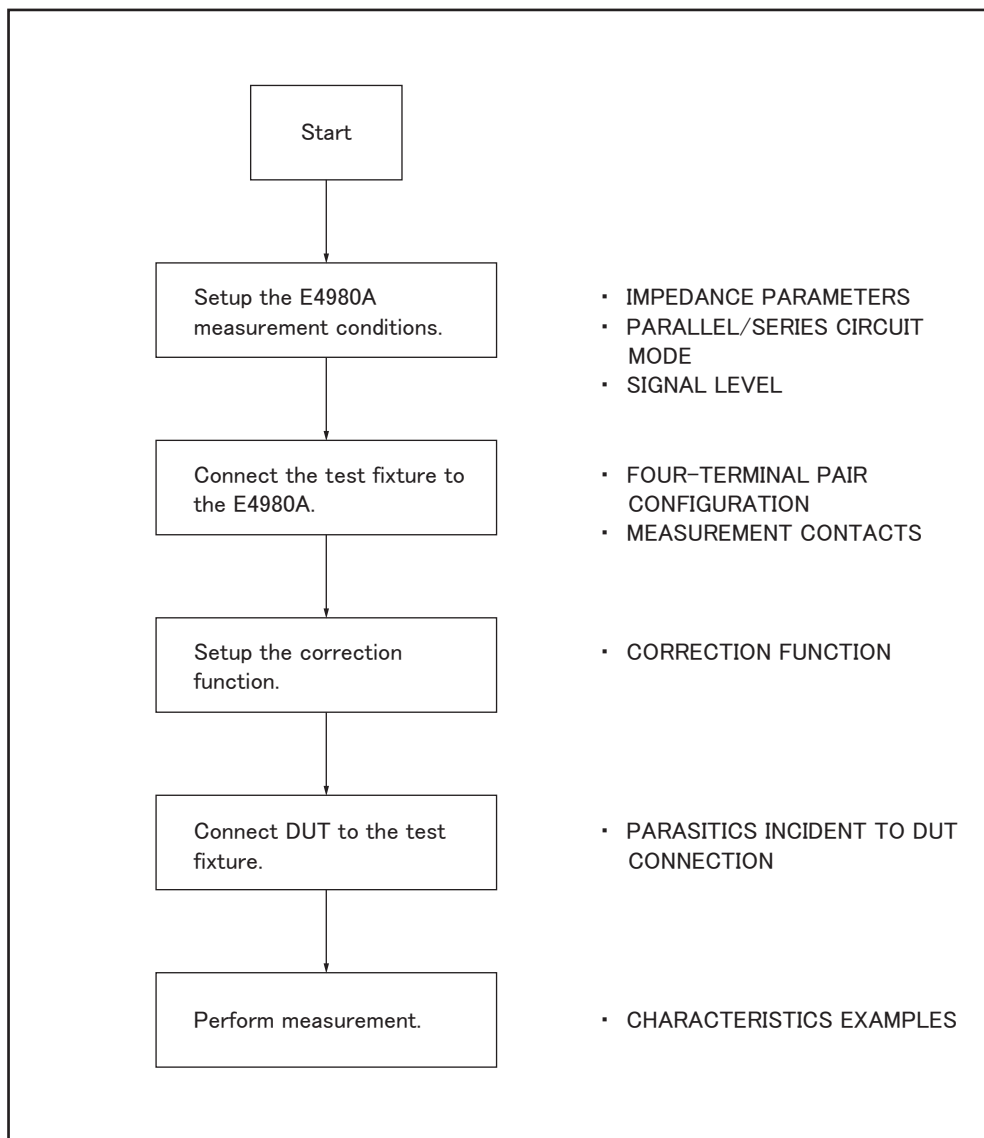

e4980aue1073

Impedance Parameters

All circuit components, resistors, capacitors, and inductors have parasitic components lurking in the shadows waiting for the unwary. These include, for example, unwanted resistance in capacitors, unwanted capacitance in inductors, and unwanted inductance in resistors. Thus, simple components should be modeled as complex impedances.

Figure 7-2(A) shows the impedance definitions, and Figure 7-2 (B) shows the vector representation of impedance. Impedance, Z is the total opposition that a circuit or device offers to the flow of alternating current at a given frequency. Z contains a real and an imaginary part, and it is expressed in rectangular form as Resistance and Reactance, or in polar form as absolute value of Impedance and Phase as follows.

$$Z = R + jX = |Z| \angle \theta$$

$$Z = \sqrt{R^2 + X^2}$$

$$\theta = \text{atan}\left(\frac{|X|}{R}\right)$$

$$R = R_s$$

Where,

Z	Impedance [Ω]
R	Resistance [Ω]
X	Reactance [Ω]
$ Z $	Absolute Value of Impedance [Ω]
θ	Phase of Impedance [deg or rad]
R_s	Series Resistance [Ω]

Figure 7-2

Definition of Impedance

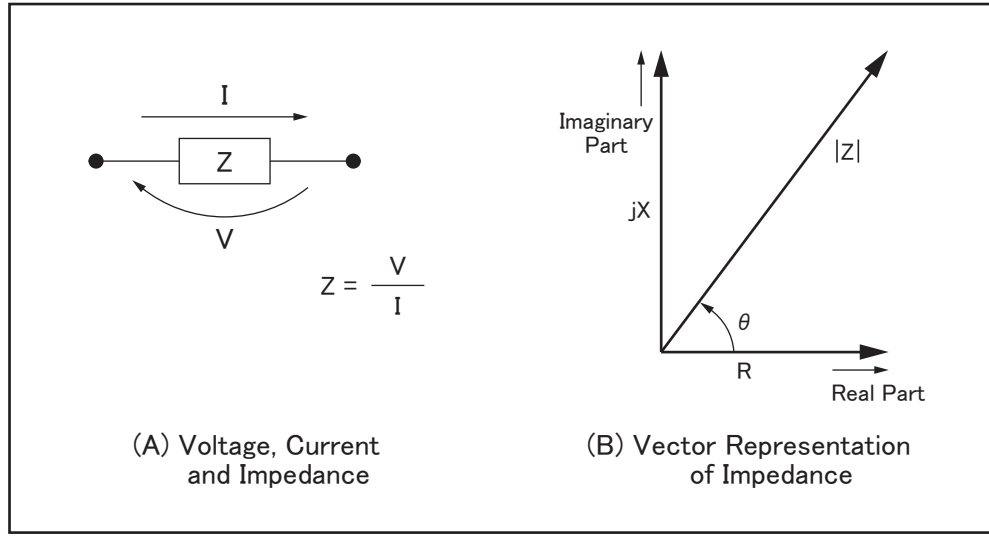

e4980aue1074

The following parameters can be used to represent the reactance.

$$X = 2\pi fL$$

where

f Test frequency [Hz]

L Inductance [H]

In addition to these parameters, the Quality Factor (Q) and Dissipation Factor (D) are used to describe the quality of components.

$$Q = \frac{1}{D} = \frac{|X|}{R}$$

where

Q Quality Factor

D Dissipation Factor

In some case, for the inverse of impedance (Admittance), Y is used. Figure 7-3 shows the vector representation of admittance. As with Z (Impedance), Y contains a real and an imaginary part, and it is expressed in rectangular form as Conductance and Susceptance, or in polar form as magnitude of Admittance and Phase. The following are expressions for Admittance.

$$Y = \frac{1}{Z}$$

$$|Y| = \sqrt{(G^2 + B^2)} = \frac{1}{|Z|}$$

$$\phi = \text{atan}\left(\frac{|B|}{G}\right) = -\theta$$

$$B = 2\pi fC$$

$$Q = \frac{1}{D} = \frac{|B|}{G}$$

$$G = \frac{1}{R_p}$$

- Y Admittance [S]
- G Conductance [S]
- B Susceptance [S]
- |Y| Magnitude of Admittance [S]
- ϕ Phase of Admittance [deg or rad]
- C Capacitance [F]
- R_p Parallel Resistance [Ω]

NOTE

The |Y|- θ measurement function of the E4980A can obtain the |Y| and ϕ parameters given in the above equations.

Figure 7-3

Vector Representation of Admittance

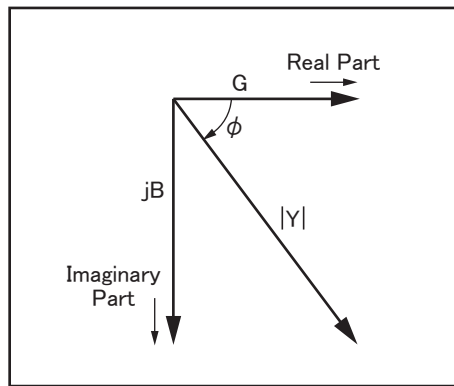

e4980aue1075

Parallel/Series Circuit Mode

To measure L, C, or R, there are two equivalent circuit modes: the parallel and series modes as shown in Table 7-1. The E4980A can select the mode by setting the FUNC (Cp, Cs, Lp, or Ls) on the MEAS SETUP page. To determine which mode is better, consider the relative impedance magnitude of the reactance and Rs and Rp.

Table 7-1 Parallel/Series Circuit Mode

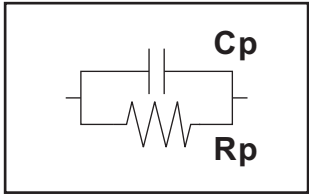
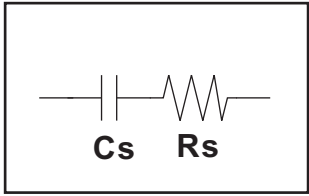
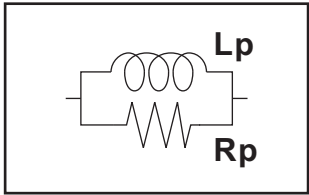
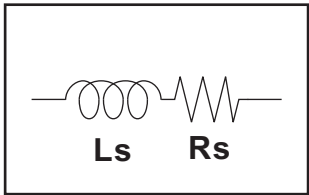
Circuit Mode	Measurement Function	Definition of D, Q, and G
<p>Cp mode</p>  <p>e4980auj1076</p>	<p>Cp-D Cp-Q Cp-G Cp-Rp</p>	$D = \frac{1}{2\pi f C_p R_p} = \frac{1}{Q}$ $G = \frac{1}{R_p}$
<p>Cs mode</p>  <p>e4980auj1077</p>	<p>Cs-D Cs-Q Cs-Rs</p>	$D = 2\pi f C_s R_s = \frac{1}{Q}$
<p>Lp mode</p>  <p>e4980auj1078</p>	<p>Lp-D Lp-Q Lp-G Lp-Rp</p>	$Q = \frac{R_p}{2\pi f L_p} = \frac{1}{D}$ $G = \frac{1}{R_p}$
<p>Ls mode</p>  <p>e4980auj1079</p>	<p>Ls-D Ls-Q Ls-Rs</p>	$Q = \frac{2\pi f L_s}{R_s} = \frac{1}{D}$

Selecting Circuit Mode of Capacitance

The following description gives some practical guidelines for selecting the capacitance measurement circuit mode.

Small Capacitance (modeled by (a) in Figure 7-4)

Small capacitance yields large reactance, which implies that the effect of the parallel resistance (R_p) has relatively more significance than that of series resistance (R_s). The low value of resistance represented by R_s has negligible significance compared with the capacitive reactance, so the parallel circuit mode (Cp-D or Cp-G) should be used.

Large Capacitance (modeled by (b) in Figure 7-4)

When the converse is true and the measurement involves a large value of capacitance (low impedance), R_s has relatively more significance than R_p , so the series circuit mode (Cs-D or Cs-Q) should be used.

Figure 7-4 Capacitance circuit mode selection

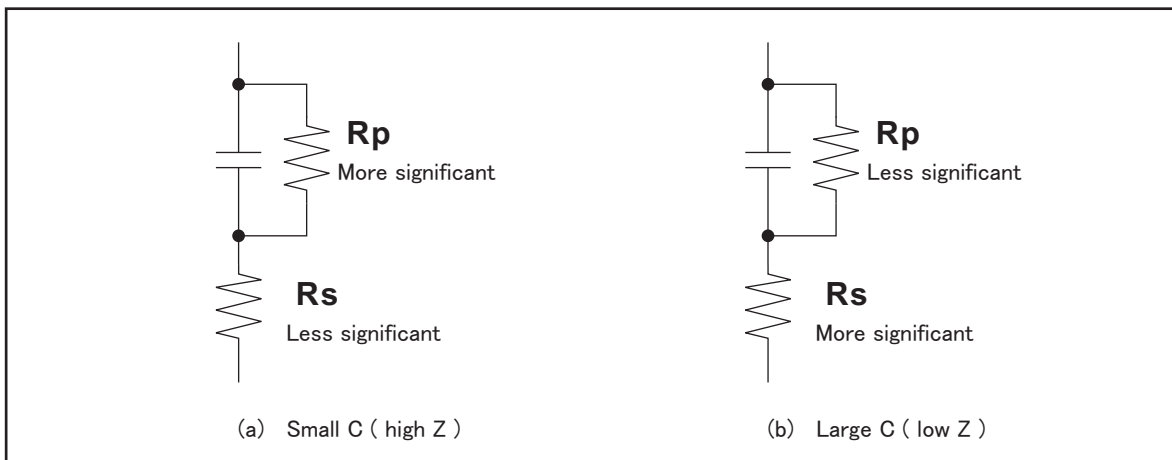

e4980aue1080

The following rule of thumb can be used for selecting the circuit mode according to the impedance of the capacitor.

- | | |
|-----------------------------|------------------------------------------|
| Above approx. 10 k Ω | Use parallel circuit mode |
| Below approx. 10 Ω | Use series circuit mode |
| Between above values | Follow the manufacturer's recommendation |

For example, to measure a 20 μF capacitor at 1 kHz (impedance will be approx. 8 Ω), the Cs-D or Cs-Q function is suitable.

Selecting Circuit Mode of Inductance

The following description gives some practical guidelines for selecting the inductance

Measurement Procedure and Examples

Parallel/Series Circuit Mode

measurement circuit mode.

Large Inductance (modeled by (a) in Figure 7-5)

The reactance at a given frequency is relatively large (compared with that of a small inductance), so the parallel resistance becomes more significant than the series resistance. Therefore, a measurement in the parallel equivalent circuit mode (Lp-D, Lp-Q, or Lp-G) is more suitable.

Small Inductance (modeled by (b) in Figure 7-5)

Conversely, for low values of inductance the reactance becomes relatively small (compared with that of a large inductance), so the series resistance component is more significant. Therefore, the series equivalent circuit mode (Ls-D or Ls-Q) is more suitable.

Figure 7-5 Inductance circuit mode selection

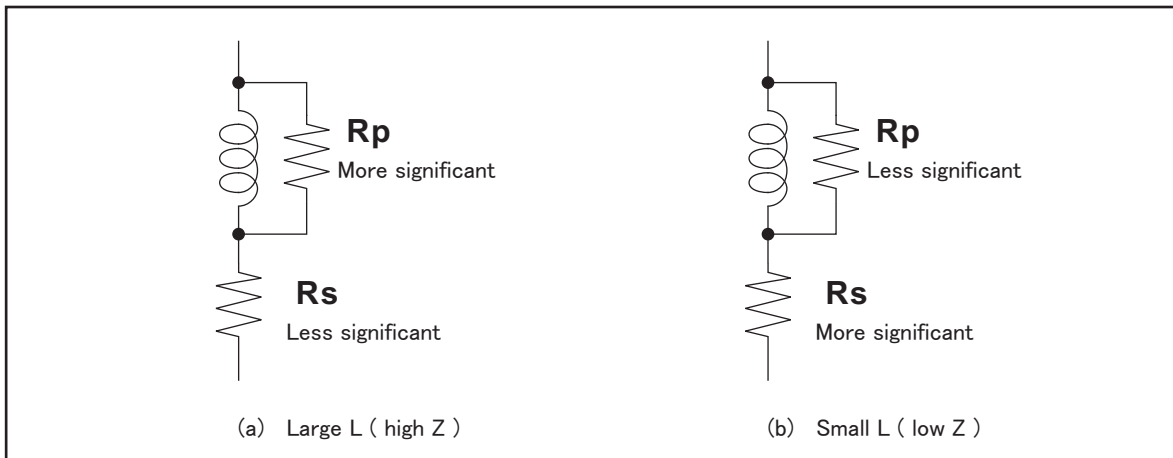

e4980aue1081

The following rule of thumb can be used for selecting the circuit mode according to the impedance of the inductor.

Below approx. $10\ \Omega$	Use series circuit mode
Above approx. $10\ \text{k}\Omega$	Use parallel circuit mode
Between above values	Follow the manufacturer's recommendation

For example, to measure a 1 mH inductor at 1 kHz (impedance will be approx. $6.3\ \Omega$), the Ls-D or Ls-Q function is suitable.

Test Signal Level

Most components have impedance characteristics that are dependent on the applied test signal level. Consequently, the test signal level should be set appropriately for each DUT.

Test Signal Level Across the DUT

Figure 7-6 shows a simplified model of the E4980A and a DUT. The test signal level across the DUT depends on the test signal level, the source resistance of the E4980A, and the impedance of the DUT as follows.

$$|Vm| = \frac{|Zx|}{|Rso + Zx|} \times |Vosc|$$

$$|Im| = \frac{|Vosc|}{|Rso + Zx|}$$

Where,

- |Vosc| Signal voltage level of E4980A
- Rso Source resistance of E4980A (= 100 Ω)
- |Vm| Signal voltage level applied on DUT
- |Im| Signal current level flowed in DUT
- |Zx| Impedance of DUT

Figure 7-6

Simplified model of test signal level and DUT

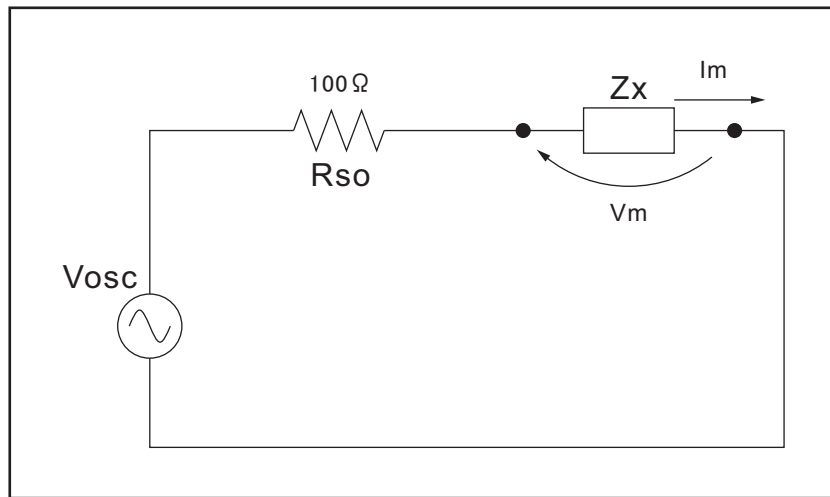

e4980auj1082

Test Signal Level Setting

The E4980A's test signal level (V_{osc} in Figure 7-6) can be set to the appropriate value in the voltage or current mode. Using the ALC (automatic level control) function, the test signal level setting is the same as the applied level across the DUT (V_m or I_m in Figure 7-6). Accordingly, the test signal level setting mode can be selected in the following four ways.

- Test signal level set as voltage and ALC set to OFF:
The open terminal voltage is set to the entered voltage value in the LEVEL field.
- Test signal level set as current and ALC set to OFF:
The short terminal current is set to the entered current value in the LEVEL field.
- Test signal level set as voltage and ALC set to ON:
The test signal level across the DUT is set to the entered voltage value in the LEVEL field.
- Test signal level set as current and ALC is set to ON:
The test signal level across the DUT is set to the entered current value in the LEVEL field.

For more information on the ALC function, refer to “Automatic level control” on page 96.

NOTE

By using the level monitor function (VAC and IAC on the MEAS DISPLAY page), the actual test signal level across the DUT (V_m and I_m in Figure 7-6) can be monitored.

Test Signal Level Setting Selection Example for Inductance Measurements

An inductor's inductance value may differ widely depending on the current through the inductor due to the permeability of its core material. Making inductance measurements under constant test signal current levels allows you to extract the frequency characteristics of the inductor in isolation from its test signal level characteristics.

To make constant current level measurements, set an appropriate test signal level in the current value and set ALC to ON. The signal current level through the inductor will be constant.

Four-Terminal Pair Configuration

Generally, any mutual inductance, interference of the test signals, or unwanted residual factors in the connection method incidental to ordinary termination methods will have a significant effect on measurement, especially at high frequency. The E4980A employs a four-terminal pair measurement configuration that permits easy, stable, and accurate measurement while avoiding the negative influences inherent in the above factors.

Figure 7-7 shows the four-terminal pair measurement principle. The set of UNKNOWN terminals consists of four coaxial connectors.

- HCUR: High current
- HPOT: High potential
- LPOT: Low potential
- LCUR: Low current

Figure 7-7 Four-terminal pair measurement principle

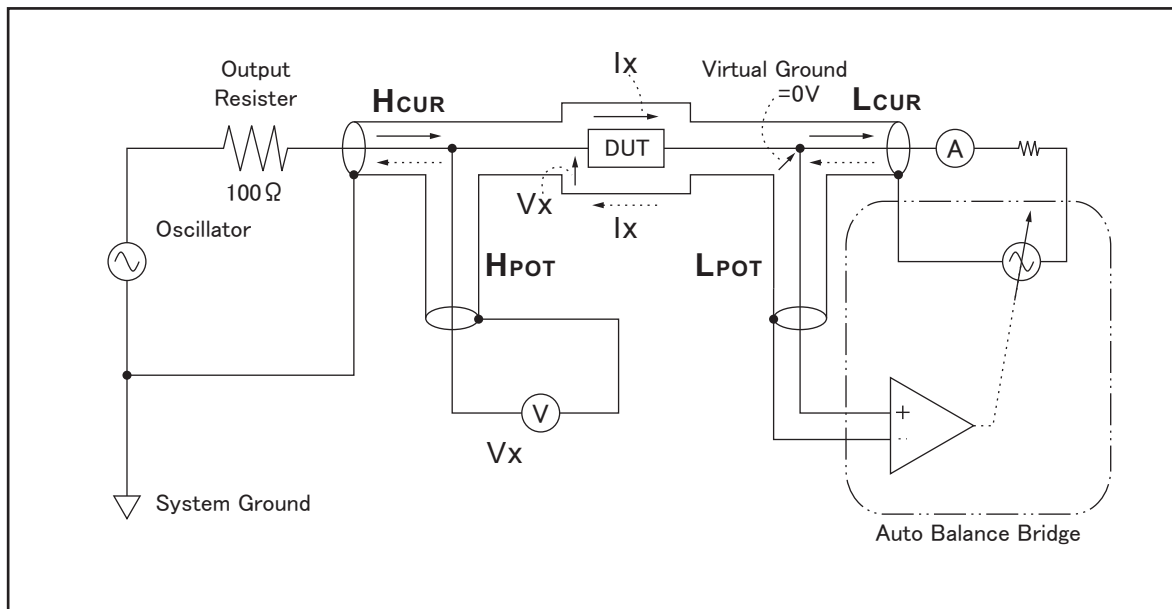

e4980aue1083

The four-terminal pair measurement method has advantages for both low- and high-impedance measurements. The outer shield conductors work as the return path for the test signal current (they are not grounded). The same current flows through both the center conductors and outer shield conductors (in opposite directions), but no external magnetic field is generated around the conductors (the magnetic fields produced by the inner and outer currents completely cancel each other). Because the test signal current does not develop an inductive magnetic field, test leads do not contribute additional errors due to self or mutual inductance between the individual leads.

Measurement Contacts

This section gives general advice and techniques for using the four-terminal pair configuration efficiently. To take accurate measurements using this technique, the following steps are required to prepare measurement contacts (the number labels in the following description correspond to the numbers in Figure 7-8).

1. The signal path between the E4980A and the DUT should be as short as possible.
2. To construct the four-terminal pair measurement circuit configuration, the outer shields of the LCUR and HPOT, LCUR and LPOT terminals must be, respectively, connected together at the nearest point possible to the point at which the DUT will be connected.
3. Keep connections between the point at which the shielding ends and DUT as short as possible.

Figure 7-8

Measurement contacts

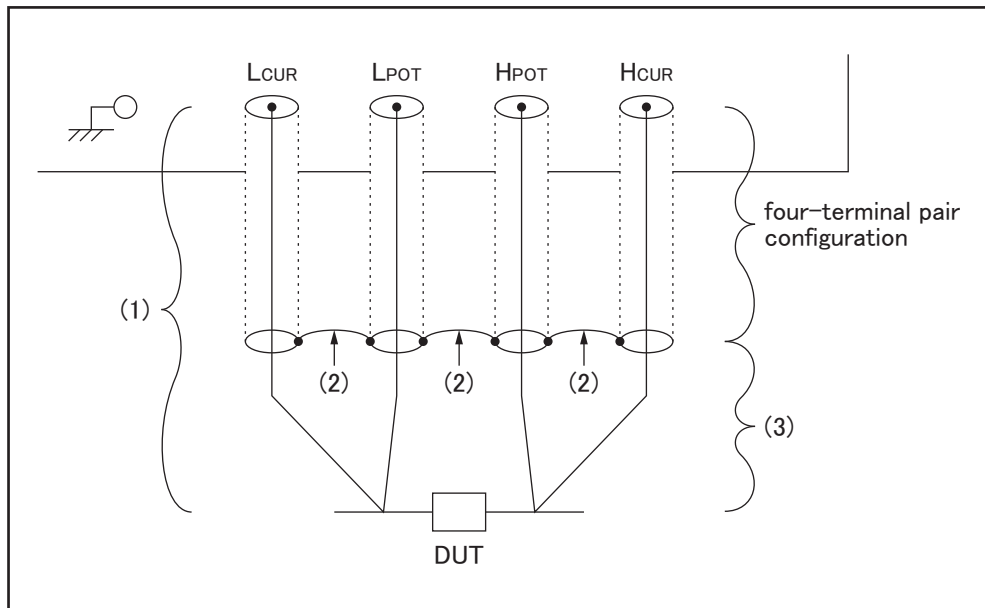

e4980aue1084

The following sections offer some techniques for using the four-terminal pair configuration effectively and efficiently.

Capacitance to Ground

In measuring capacitors of 10 pF or less, the stray capacitance (when the conductors are grounded, this is capacitance to ground) between the measurement contacts and the conductors near the capacitor influences the measurement as shown in Figure 7-9.

Figure 7-9 Model of Capacitance to Ground

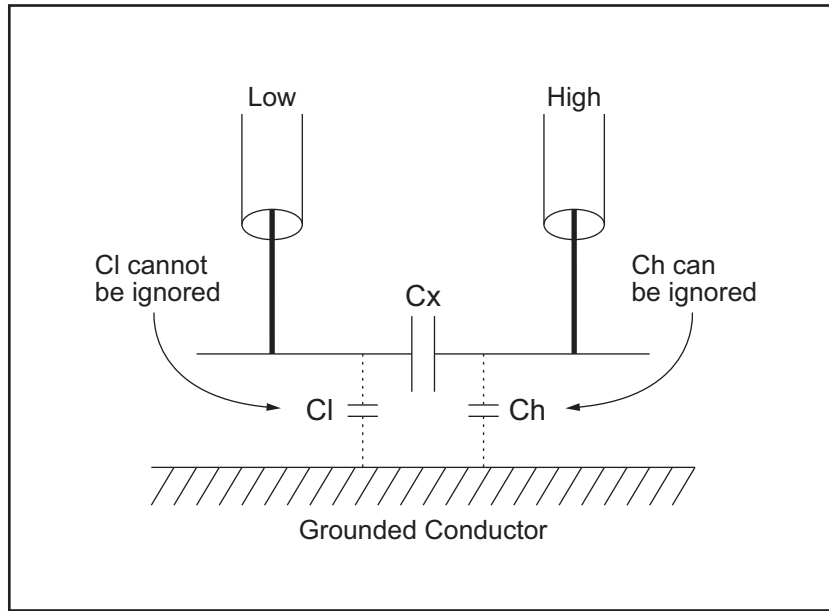

e4980aue1085

To minimize the stray capacitance of the test leads, the center conductor of the test leads should be kept as short as possible, as shown in Figure 7-10 (A). If four-terminal pair connections are close to the point where contact is made with the DUT, interconnect the shields of the measurement terminals to the conductor to reduce the influence of the stray capacitance to ground, as shown in Figure 7-10 (B).

Figure 7-10 Reducing capacitance to ground

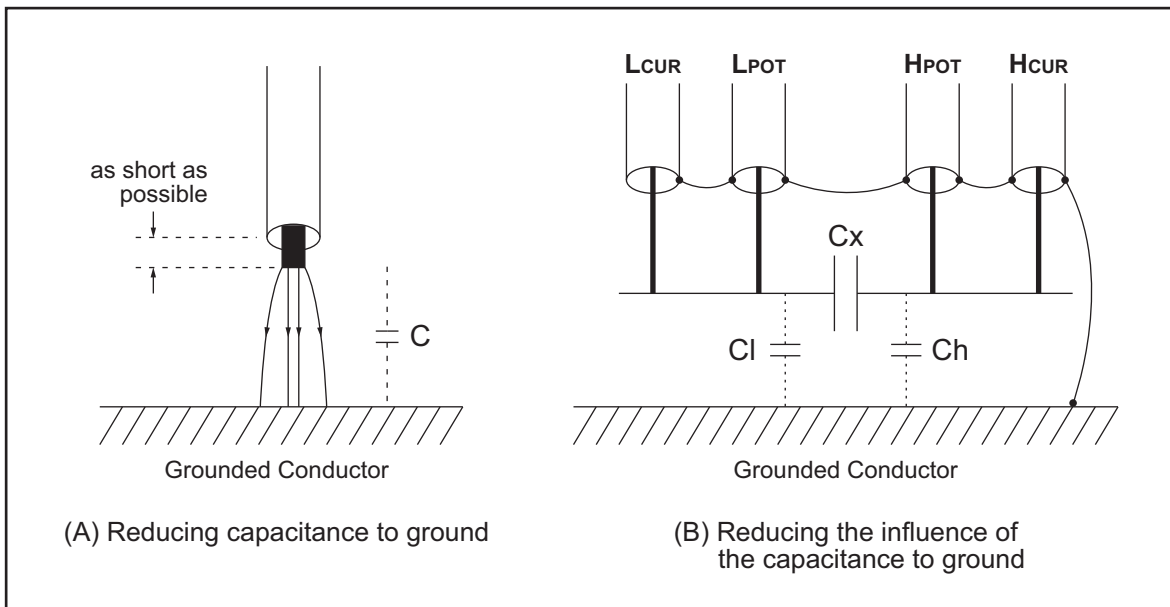

e4980aue1086

Contact Resistance

Contact resistance between the contacting terminals and the DUT causes measurement error when measuring large values of capacitance, especially in D (dissipation factor) measurements.

When measuring large capacitance values, the four-terminal measurement contacts have the advantage of less measurement error as compared to the two-terminal method. Select a test fixture which can hold the DUT tightly to stabilize the connection.

Figure 7-11 Contact resistance

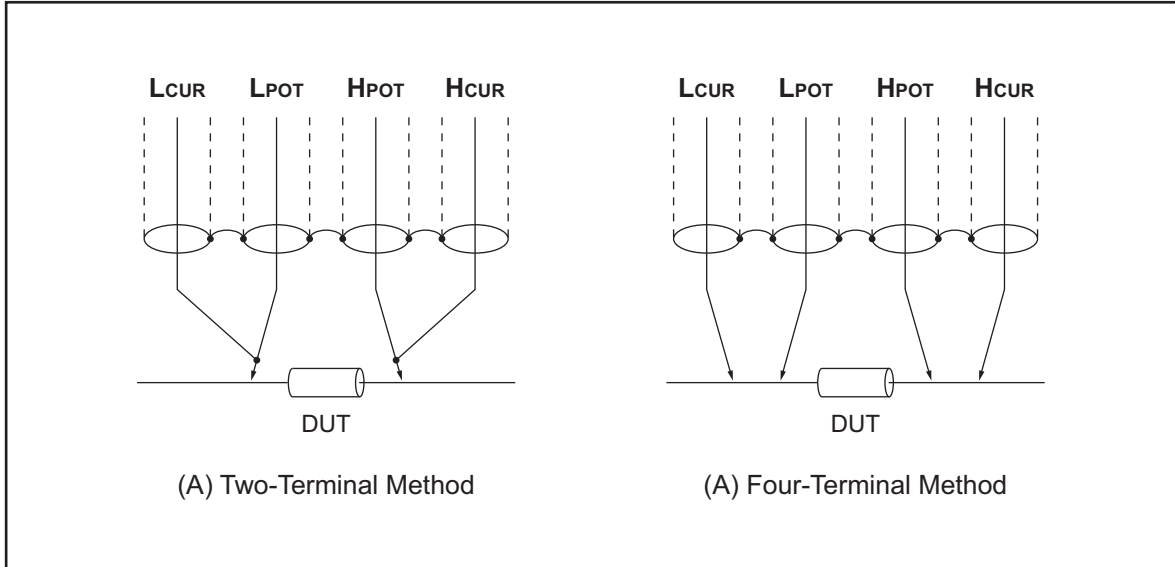

e4980aue1087

Extending Test Leads

When extending the four-terminal pair test leads to the contacts of the DUT, prepare the contacts as shown in Figure 7-12. If the measurement contact cannot be made using the four-terminal pair configuration, use one of the connection methods shown in Figure 7-13 to make the measurement contact.

Figure 7-12

Extending the four-terminal pair test leads

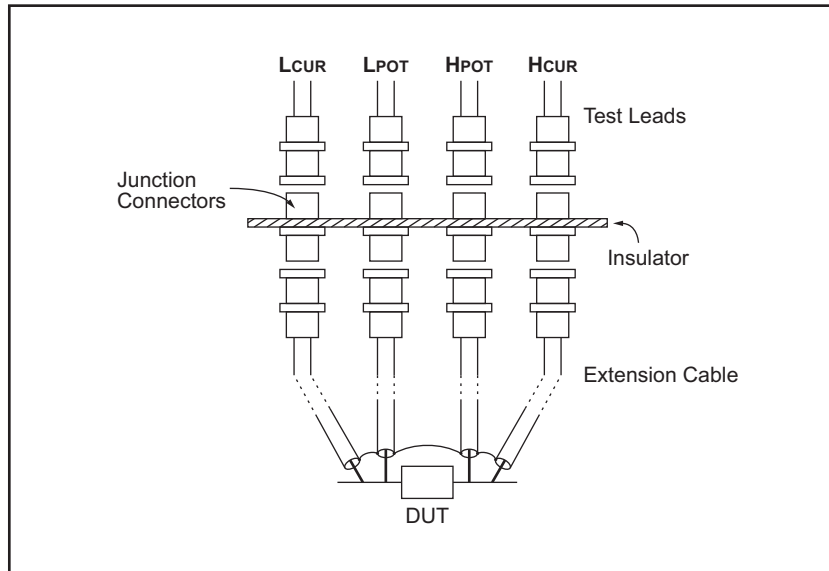

e4980aue1088

7. Measurement Procedure and Examples

Figure 7-13 Measurement contacts for test leads extension

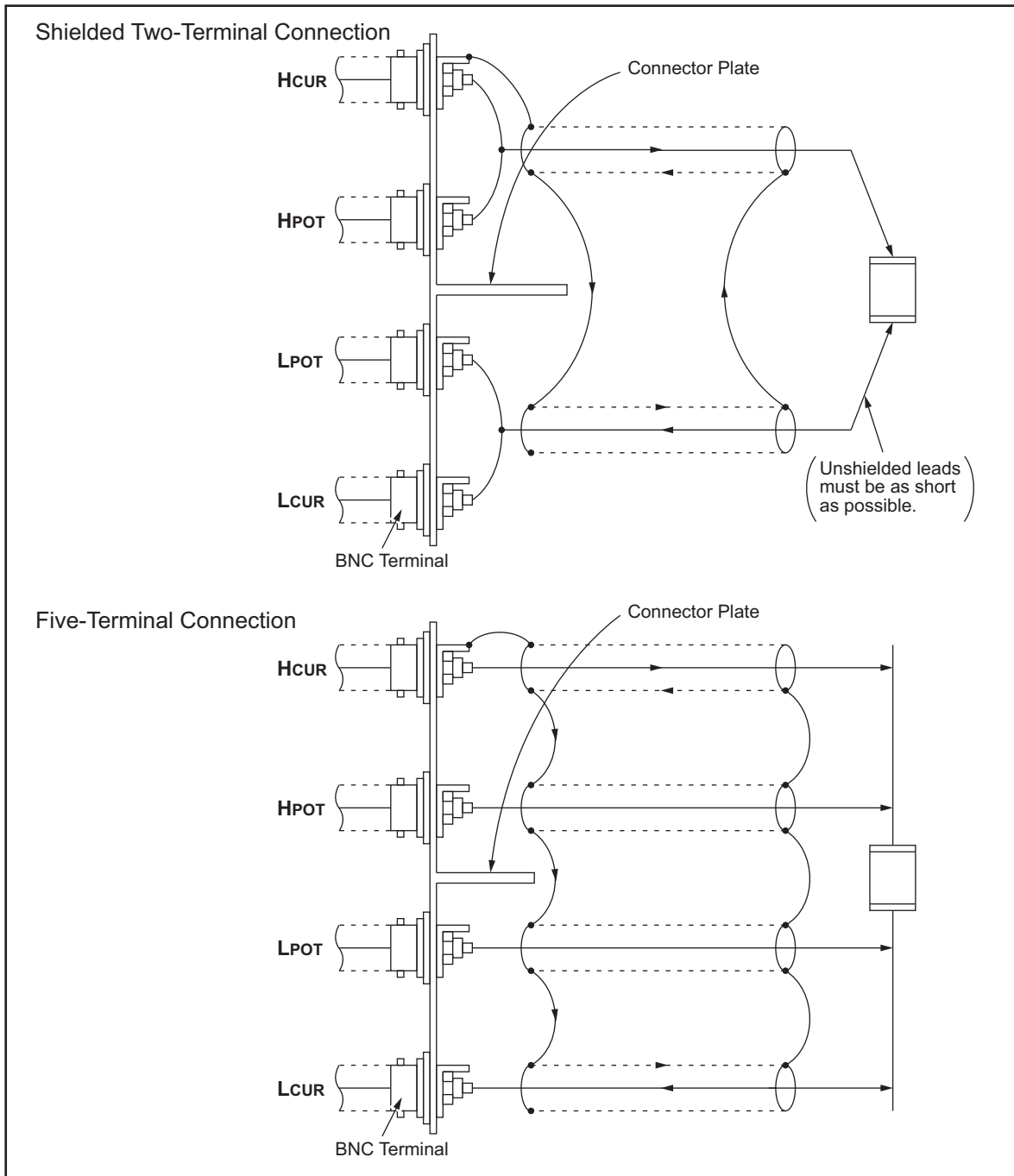

e4980aue1114

Guarding for Measurement of Low Capacitance Values

Use a guard plate to minimize measurement errors caused by stray capacitance when measuring low capacitance values, such as low-capacitance chip capacitors. Figure 7-14 shows an example of measurement contacts using a guard plate in the four-terminal pair measurement configuration.

Figure 7-14

Example DUT Guard Plate Connection

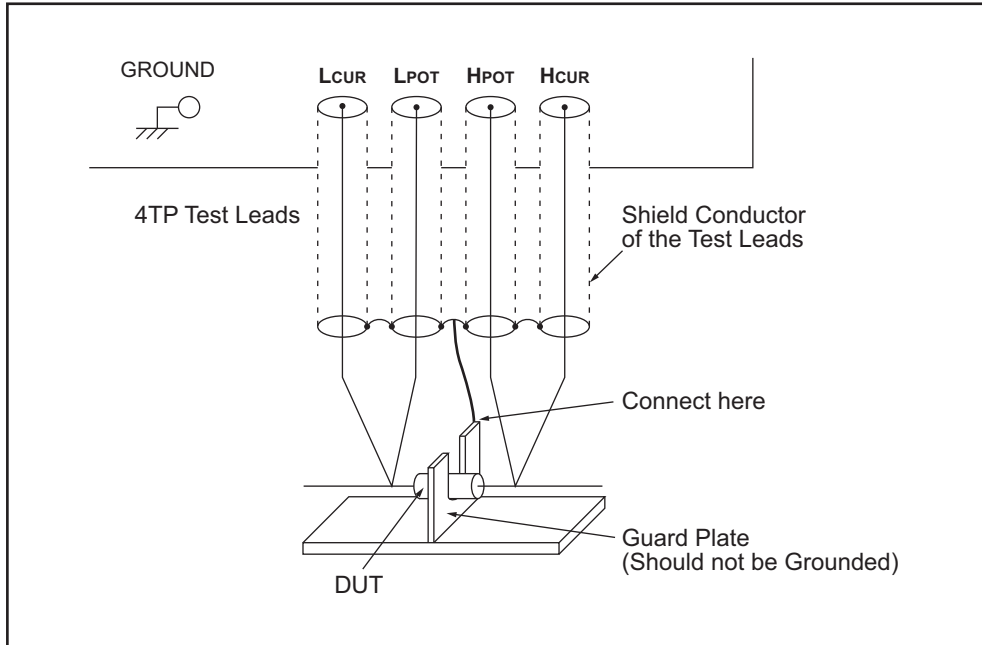

e4980aue1115

7. Measurement Procedure and Examples

Shielding

Shielding minimizes the effects of electrical noise picked up by the test leads. Therefore, connect a shield plate to the outer shield conductors of the four-terminal pair test leads as shown in Figure 7-15.

Figure 7-15

Guard shield

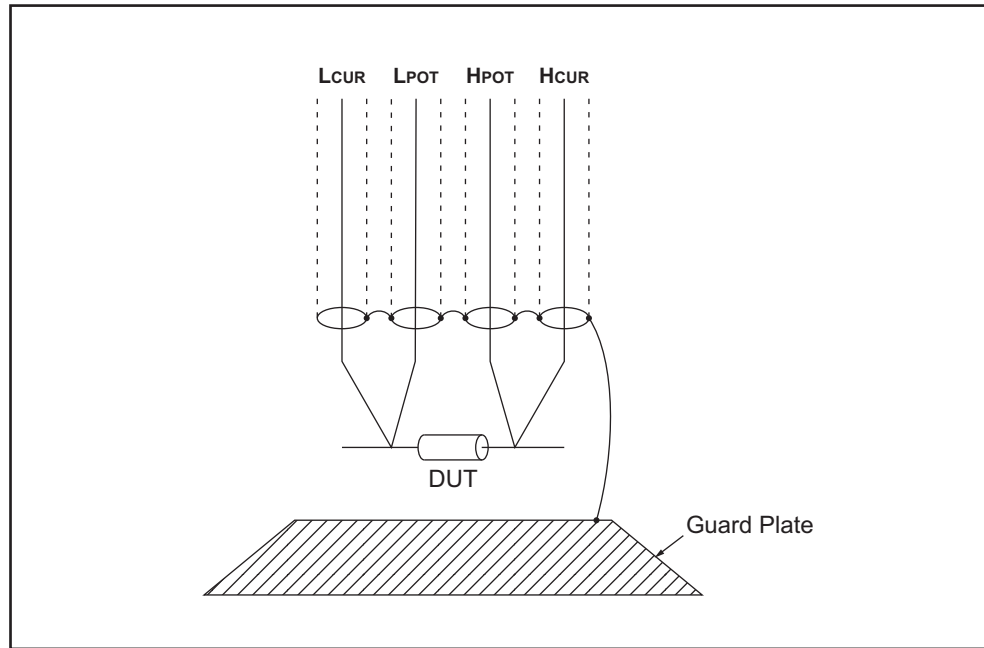

e4980aue1116

Correction Functions

The E4980A features powerful correction functions: Cable Length correction as well as OPEN, SHORT, and LOAD corrections. These correction functions are used to correct additional error due to the test fixture and the test leads. Table 7-2 lists the correction functions with a brief description, and Table 7-3 shows examples of using correction functions.

Table 7-2

Correction functions

Correction Function	Description	Typical Usage
Cable Length Correction	Compensate phase shift error due to the 1, 2, or 4 m test leads.	<ul style="list-style-type: none"> Measurements using the Agilent 16048A/B/C/D/E or Agilent 16334A
OPEN Correction	Compensate stray admittance due to the test fixture.	<ul style="list-style-type: none"> High-impedance measurements
SHORT Correction	Compensate residual impedance due to the test fixture.	<ul style="list-style-type: none"> Low-impedance measurements
OPEN/SHORT Correction	Compensate the stray admittance and residual impedance due to the test fixture.	<ul style="list-style-type: none"> Precise measurements
OPEN/SHORT/LOAD Correction	Compensate any error due to the test fixture and test leads by using the standard.	<ul style="list-style-type: none"> Measurements to be referenced to a standard Measurements using a test fixture that has complicated impedance characteristics

Table 7-3 Examples of correction functions

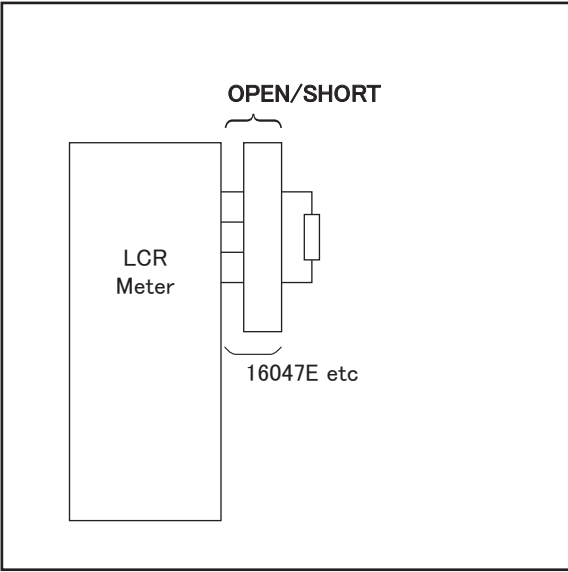
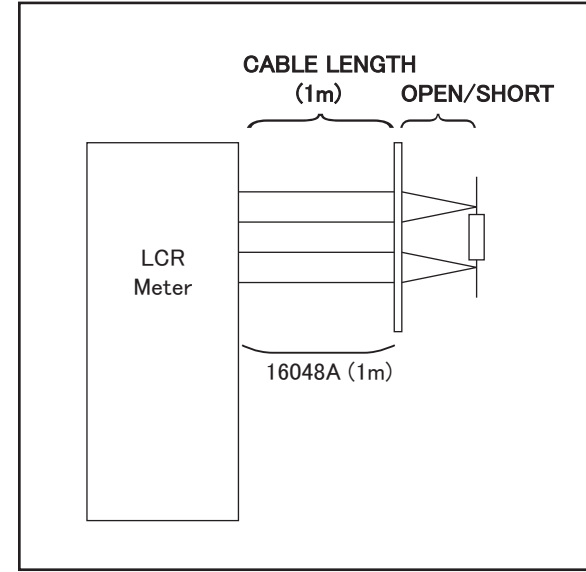
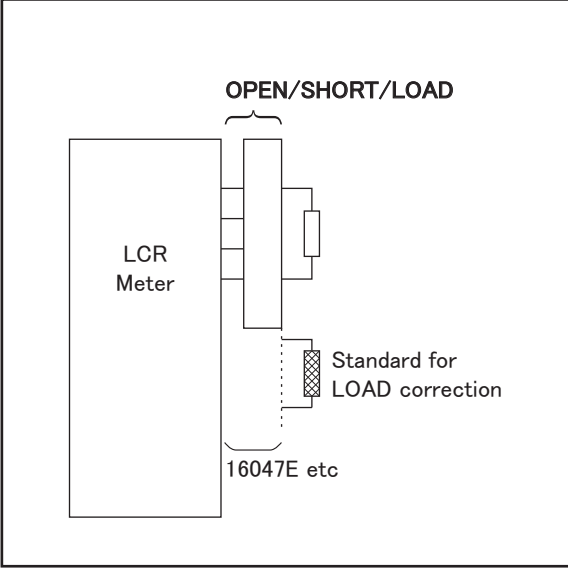
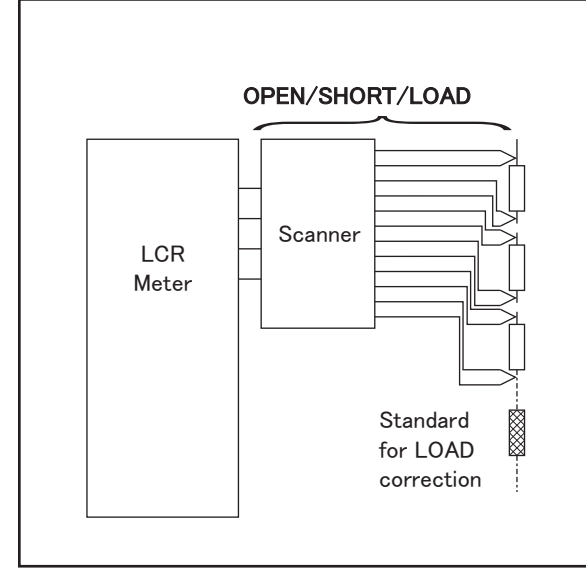
<ul style="list-style-type: none"> Simple measurements using an Agilent-supplied direct-connecting test fixture  <p>e4980aue1089</p>	<ul style="list-style-type: none"> Measurements using Agilent test leads and a test fixture  <p>e4980aue1090</p>
<ul style="list-style-type: none"> Precise measurements to be referenced to a working standard  <p>e4980aue1091</p>	<ul style="list-style-type: none"> Measurements using a test fixture that has complicated impedance characteristics  <p>e4980aue1092</p>

Performing OPEN Correction

To perform an OPEN correction data measurement, set up an OPEN condition where nothing is connected to the test fixture. While the OPEN measurement is being performed, don't touch the test fixture or move your hands near it.

NOTE

In the OPEN condition, H_p and H_c , and L_p and L_c are connected. For the OPEN condition of the fixture, refer to the fixture's manual.

Performing SHORT Correction

To perform a SHORT correction data measurement, set up a SHORT condition by using a shorting bar to short between the high terminal and low terminal of the UNKNOWN terminals.

Figure 7-16 shows a sample shorting bar for the Agilent 16047E test fixture. The shorting bar should have very low residual impedance, so be sure to use a high-conductivity metal plate that does not easily corrode for the shorting plate. Furthermore, it must be clean.

Figure 7-16 Sample Shorting Plate

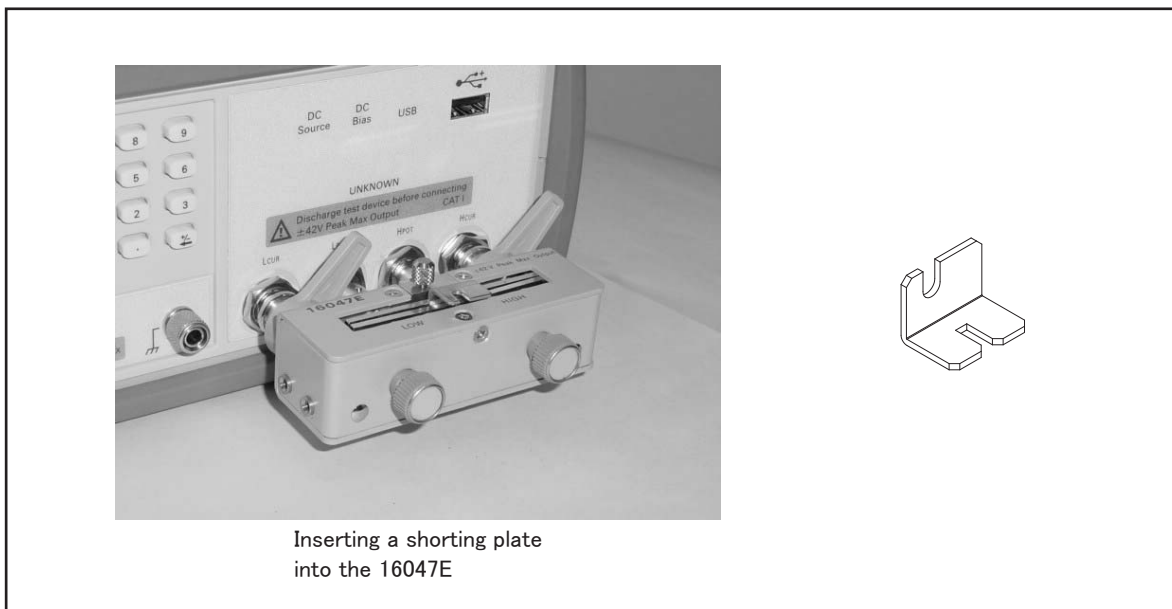

e4980aue1093

Performing LOAD Correction

To perform LOAD correction data measurement, connect the LOAD standard to the measurement contacts.

Preparing the Standard

It is necessary to prepare a working standard, such as a standard resistor or standard capacitor. Try to select a standard whose impedance is as close as possible to the impedance of the DUT. Consider the following recommendations for selecting standards.

- For capacitance measurements:
A standard capacitor whose capacitance is nearly equal to the capacitance of the DUT is recommended.
- For resistance measurements:

Measurement Procedure and Examples

Correction Functions

A standard resistor whose resistance is nearly equal to the resistance of the DUT is recommended.

- For inductance measurements:

A standard inductor whose inductance is nearly equal to the inductance of the DUT is recommended.

Reference Values of the LOAD Standard

Enter specified reference values of the standard as the REF A and REF B values by using the appropriate function on the CORRECTION page. For example, when using a standard capacitor that has a specified parallel capacitance and D values, enter the specified parallel capacitance value as the REF A value and the specified D value as the REF B value with the Cp-D function.

NOTE

If the REF A and REF B values are entered with the Cp-D function, measurements with other functions (such as the $|Z|$ - θ function) can also be performed.

Using the Pre-Measured Device for the LOAD

Even if you have no standard with the specified reference values, you can perform a LOAD correction using a device such as a general purpose capacitor or resistor. The pre-measured values of a device are used for the REF A and REF B values. Follow the procedure shown below to use a device for the LOAD standard.

- Step 1.** For the LOAD standard, prepare a device that has an impedance as close as possible to the impedance of the DUT.
- Step 2.** If the device has BNC connectors structured in the four-terminal pair configuration, measure the device directly by connecting it directly to the E4980A: Do not use a test fixture. If the device does not have four-terminal pair measurement terminals, measure the device using a direct coupling test fixture (such as the Agilent 16047A/C/D/E).
- Step 3.** On the CORRECTION page, enter the measured values obtained in step 2 as the REF A and REF B values with the function used in step 2.

Parasitics Incident to DUT Connection

Bear in mind that some parasitics remain in the measurement path even after performing corrections, as shown below.

Figure 7-17 shows parasitic impedance model after corrections are performed using the Agilent 16047A/D/E test fixture. In this case, to minimize the influence of parasitics on measurement values, insert the DUT completely into the test fixture while keeping the leads of the DUT as short as possible.

Figure 7-17

Parasitic impedance model (using Agilent16047A/D/E)

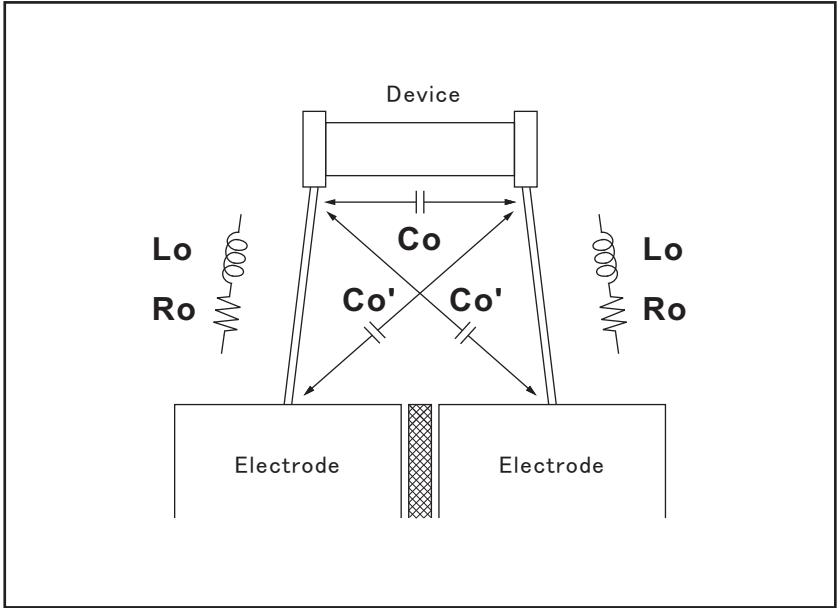

e4980aue1094

- Lo Residual inductance in DUT lead
- Ro Lead resistance in DUT lead
- Co Stray capacitance

Characteristics Example

Table 7-4 shows typical characteristics of various components. As can be seen in the figure, a component may have different effective parameter values depending on its operating conditions. The measured values most useful in actual applications are obtained from precise measurement under the actual operating conditions.

Table 7-4 Typical characteristics of components

DUT	Characteristics Example	Measurement Functions
Large C	 <p>e4980auj1095</p>	Cs-Rs, Cs-D, Cs-Q, R-X, $ Z -\theta$
Small C	 <p>e4980auj1096</p>	Cp-D, Cp-G, G-B, $ Y -\theta$
Large L	 <p>e4980auj1097</p>	Lp-Rp, Lp-D Lp-Q, G-B, $ Y -\theta$

Table 7-4 Typical characteristics of components

DUT	Characteristics Example	Measurement Functions
Small L	 <p>e4980auj1098</p>	$Ls-Rs, Ls-D, Ls-Q, R-X,$ $ Z -\theta$
Large R	 <p>e4980auj1099</p>	$Cp-Rp, G-B, Y -\theta$
Small R	 <p>e4980auj1100</p>	$Ls-Rs, R-X, Z -\theta$

7. Measurement Procedure
 and Examples

Capacitor Measurements

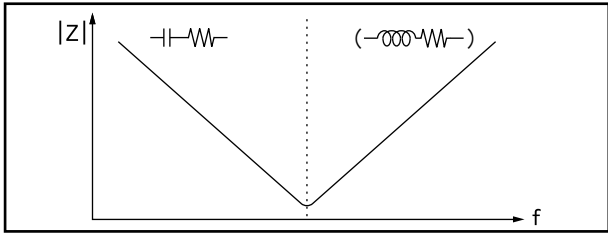
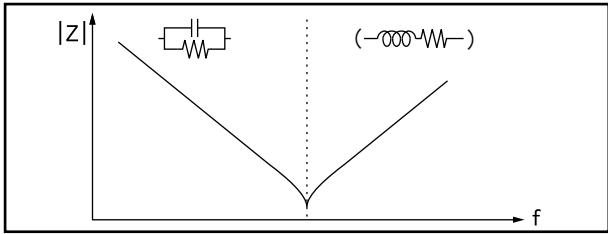
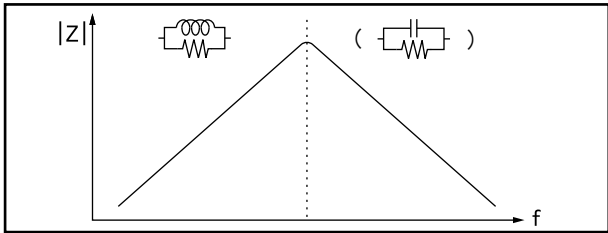
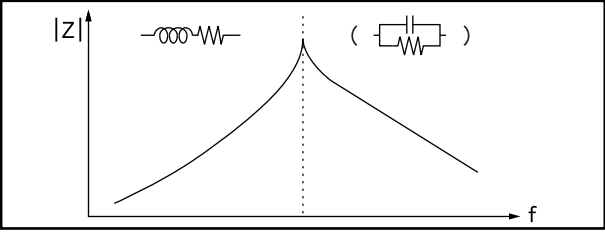
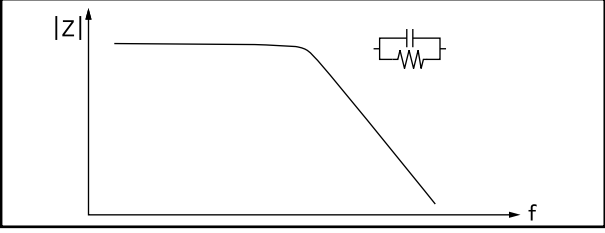
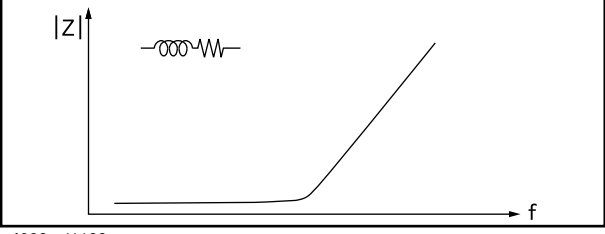
This paragraph describes a practical example of measuring a ceramic capacitor.

The basic procedure flow to perform this measurement is the same as the Basic Measurement Procedure described previously. In this example, a ceramic capacitor is measured under the following conditions.

Sample (DUT)	Ceramic capacitor
Measurement Conditions	<ul style="list-style-type: none">• Function: Cp-D• Test Frequency: 1 MHz• Test Signal Level: 1.5 V

Step 1. Turn the E4980A ON.

Step 2. Set up the E4980A's measurement conditions by filling in the fields on the MEAS DISPLAY page.

1. Move to the FREQ field using the cursor keys and input 1 MHz.
2. Move to the LEVEL field using the cursor keys and input 1.5 V.

Step 3. Connect the test fixture to the E4980A (refer to Figure 7-18). The Agilent 16047E Direct Couple Test Fixture (general purpose) is used for this measurement.

Figure 7-18

Connecting the 16047E



e4980auj1117

Step 4. To compensate for the Agilent 16047E's residuals and strays, an OPEN/SHORT correction is required.

1. Leave the Agilent 16047E in an OPEN condition as shown in Figure 7-18.

2. Press the [Meas Setup] key and the **CORRECTION** softkey.
3. Move to the OPEN field by using the cursor keys and press the **MEAS OPEN** softkey.
Wait until the message “OPEN measurement in progress” disappears.
4. Press the **ON** softkey to enable an OPEN correction.
5. Connect a shorting bar to the Agilent 16047E to set up the SHORT condition as shown in Figure 7-19.

Figure 7-19 Connecting a shorting bar



e4980auj1118

6. Move to the SHORT field using the cursor keys and press the **MEAS SHORT** softkey.
Wait until the message “SHORT measurement in progress” disappears.
 7. Press the **ON** softkey to enable a SHORT correction.
- Step 5.** Connect DUT to the test fixture as shown in Figure 7-20

Measurement Procedure and Examples Capacitor Measurements

Figure 7-20 Connecting DUT

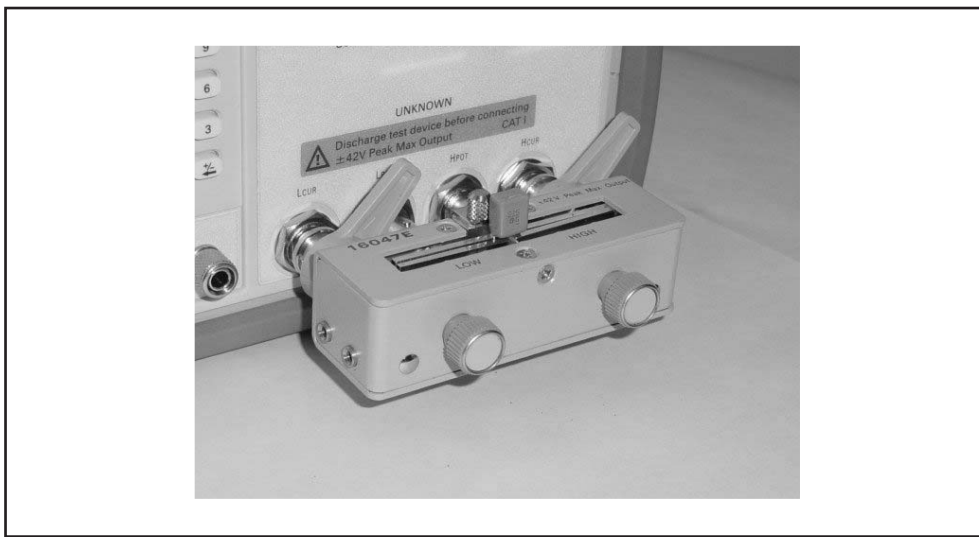

e4980auj1119

Step 6. Press the [Meas Setup] key. Measurements are performed continuously by the internal trigger, and the measured C_p and D values of the capacitors are displayed as shown in Figure 7-21.

Figure 7-21 Measurement results of Capacitor

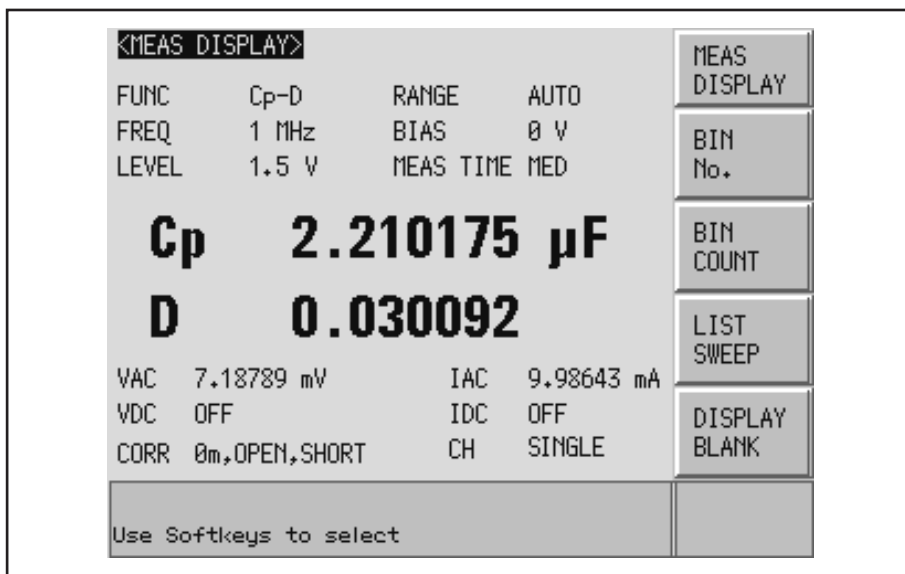

e4980auj1120

Inductance Measurements

This section describes a practical example of measuring a magnetic-core inductor.

The basic procedure flow to perform this measurement is the same as the Basic Measurement Procedure described previously. A magnetic-core inductor is measured under the following conditions.

Sample (DUT)	Magnetic-core inductor
Measurement Conditions	<ul style="list-style-type: none"> • Function: Ls-Rdc • Test frequency: 100 kHz • Test Signal Level: 10 mA (constant)

- Step 1.** Turn the E4980A ON.
- Step 2.** Set up the E4980A measurement conditions by filling in the fields on the MEAS DISPLAY page.
1. Move to the FUNC field using the cursor keys and select Ls-Rdc.
 2. Move to the FREQ field using the cursor keys and input 100 kHz.
 3. Move to the LEVEL field using the cursor keys and input 10 mA.
- Step 3.** Connect the test fixture to the E4980A as shown in Figure 7-18. The 16047E Direct Couple Test Fixture (general purpose) is used for this measurement.
- Step 4.** Perform the correction. To compensate for the Agilent 16047E's residuals and strays, an OPEN/SHORT correction is required.
1. Leave the 16047E in an OPEN condition as shown in Figure 7-18.
 2. Press the [Meas Setup] key and the **CORRECTION** softkey.
 3. Move to the OPEN field using the cursor keys and press the **MEAS OPEN** softkey.
 Wait until the message "OPEN measurement in progress" disappears.
 4. Press the **ON** softkey to enable an OPEN correction.
 5. Connect a shorting bar to the Agilent 16047E to set up the SHORT condition as shown in Figure 7-19.
 6. Move to the SHORT field using the cursor keys and press the **MEAS SHORT** softkey.
 Wait until the message "SHORT measurement in progress" disappears.
 7. Press the **ON** softkey to enable a SHORT correction.
- Step 5.** Connect the DUT to the test fixture as shown in Figure 7-22.

Figure 7-22 **Connecting DUT**

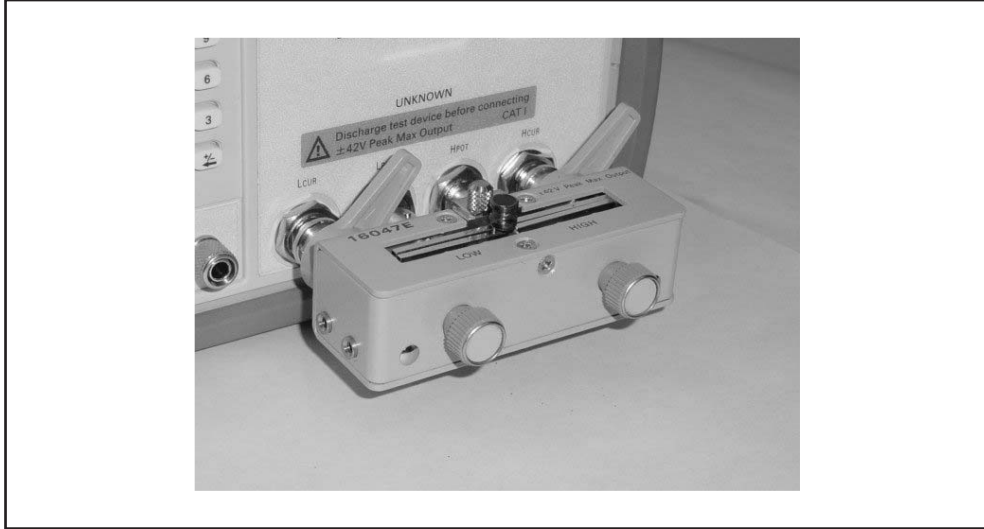

e4980auj1121

Step 6. Press the [Meas Setup] key to display the MEAS DISPLAY page.

1. Move to the ALC field using the cursor keys to press the **ON** softkey.

When it is set to ON, the test signal current level through the DUT is set to a constant value (the value set in the LEVEL field).

Step 7. Press the [Meas Setup] key. Measurements are performed continuously by the internal trigger, and the measured Ls and Rdc values of the magnetic core inductor are displayed.

Figure 7-23 **Measurement results for magnetic core inductor**

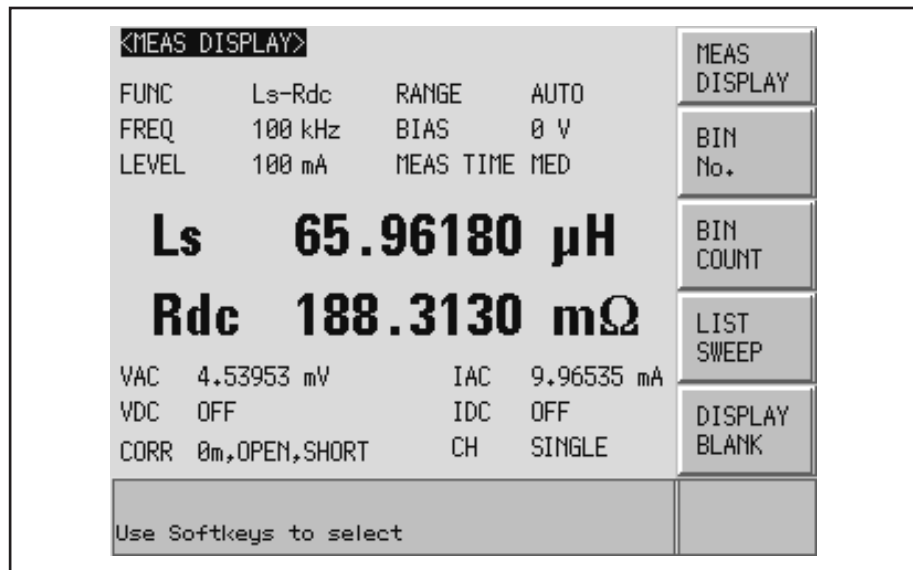

e4980auj1122

Measurements Using DC source

This section describes a practical measurement example of the E4980A using the DC source. The list sweep is used for this measurement. The basic procedure flow to perform this measurement is the same as the Basic Measurement Procedure described previously.

NOTE When option 001 is not installed, the DC source cannot be used.

NOTE The DC source has a 45 mA current-supply capability. If you want to limit the base current of the transistor, insert a resistor between the DC source and the base.

Sample (DUT)	Transistor
Measurement Conditions	• Function: R-X

- Step 1.** Turn the E4980A ON.
- Step 2.** Set up the E4980A measurement conditions by filling in the fields on the MEAS DISPLAY page.
 1. Move to the FUNC field using the cursor keys and select R-X.
- Step 3.** Press the [Meas Setup] key to set the following measurement conditions in each field of the LIST SWEEP SETUP page.
 1. Set the list sweep parameter to **DC SRC[V]**.
 2. Enter the level of the sweep point.
- Step 4.** Connect the test fixture to the E4980A as shown in Figure 7-18. The 16047E Direct Couple Test Fixture (general purpose) is used for this measurement.
- Step 5.** Perform the correction. To compensate the Agilent 16047E's residuals and strays, an OPEN/SHORT correction is required.
 1. Leave the 16047E in an OPEN condition as shown in Figure 7-18.
 2. Press the [Meas Setup] key and the **CORRECTION** softkey.
 3. Move to the OPEN field using the cursor keys and press the **MEAS OPEN** softkey.
 Wait until the message "OPEN measurement in progress" disappears.
 4. Press the **ON** softkey to enable an OPEN correction.
 5. Connect a shorting bar to the Agilent 16047E to set up the SHORT condition as shown in Figure 7-19.
 6. Move to the SHORT field using the cursor keys and press the **MEAS SHORT** softkey.
 Wait until the message "SHORT measurement in progress" disappears.
 7. Press the **ON** softkey to enable a SHORT correction.

Measurement Procedure and Examples
Measurements Using DC source

Step 6. Connect the transistor base and DC source. The corrector and emitter are connected to the DUT.

Figure 7-24 **Connecting DUT**



e4980auj1172

Step 7. Press the [Meas Setup] key to set the following measurement conditions in each field of the LIST SWEEP SETUP page

1. Set the list sweep parameter to **DC SRC[V]**.
2. Enter the level of the sweep point.

Step 8. Press the [DC BIAS] key. **DCSRC** is displayed in the status display area and the LED indicator of the DC source is ON (orange).

Figure 7-25 **Measurement results when using DC source**

<LIST SWEEP DISPLAY>						MEAS DISPLAY
MODE No.	DC SRC[V]	R[Ω]	X[Ω]	CMP		BIN No.
1	-2	12.3968 k	-2.96610 M	-		
2	-1.556	23.7808 k	-2.96234 M	-		
3	-1.111	17.4196 k	-2.96674 M	-		
4	-667 m	22.9960 k	-2.96653 M	-		BIN COUNT
5	-222 m	14.2346 k	-2.95628 M	-		
6	222 m	908.588 k	-308.901 k	-		LIST SWEEP
7	667 m	335.522	4.33817	-		
8	1.111	6.05794	178.037 m	-		DISPLAY BLANK
9	1.556	3.01404	143.425 m	-		
10	2	2.27367	151.043 m	-		
Use softkeys to select						DCSRC

e4980auj1173

8

Overview of Remote Control

This chapter provides an overview of the remote control system and the SCPI commands.

Types of remote control system

Depending on the system controller and the interface, you can configure three types of remote control system as shown in the table below.

System controller	Interface	Overview
External Controller (external computer such as PC)	GPIB	System to control the E4980A and other devices connected via GPIB from the external controller. For more information, refer to “GPIB remote control system” on page 227.
	LAN	System to control the E4980A and other devices connected via LAN from the external controller. For more information, refer to “LAN remote control system” on page 229.
	USB	System to control the E4980A and other devices connected via USB from the external controller. For more information, refer to “USB Remote Control System” on page 241.

NOTE

You must install Agilent I/O Libraries Suite in the external controller in advance.

Use Agilent I/O Libraries Suite 14 or higher.

For further information on I/O Libraries Suite, see the Agilent I/O Libraries Suite manual.

Agilent I/O Libraries Suite may not be available for certain external controllers or OS versions. For further details, refer to the Help guidance for Agilent I/O Libraries Suite.

GPIB remote control system

What is GPIB?

GPIB (General Purpose Interface Bus) is an interface standard for connecting computers and peripherals that supports the following international standards: IEEE 488.1, IEC-625, IEEE 488.2, and JIS-C1901. The GPIB interface allows you to control the Agilent E4980A from an external computer. The computer sends commands and instructions to the E4980A and receives data sent from the E4980A via the GPIB.

System configuration

Use GPIB cables to make connections between the E4980A, the external controller (computer), and peripherals. Figure 8-1 shows an overview of the GPIB remote control system's configuration.

Figure 8-1

Configuration of the GPIB remote control system

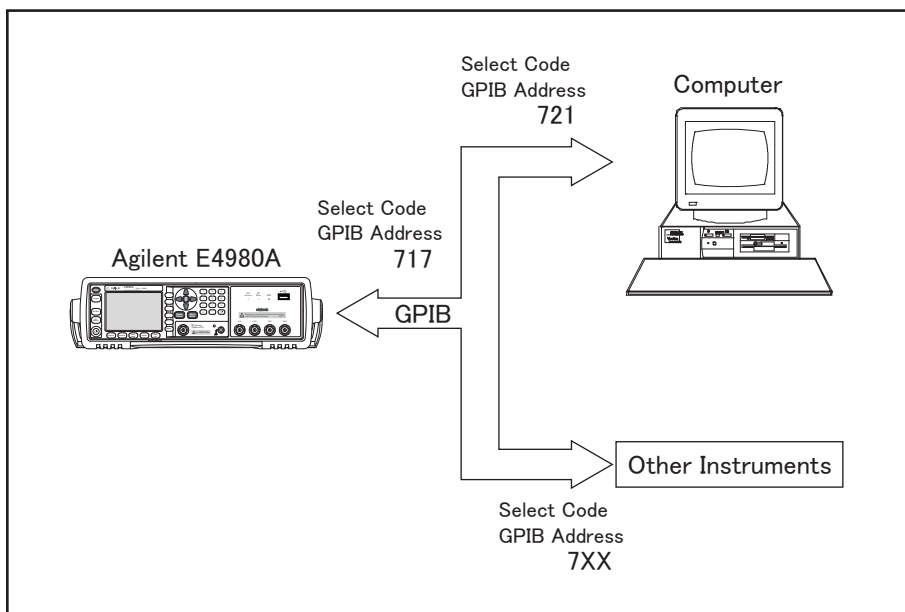

e4980aue1004

Overview of Remote Control GPIB remote control system

Required Equipment

1. E4980A
2. External controller (computer)
Use a personal computer or workstation equipped with the GPIB interface. You need to install software to control this instrument via the GPIB into the external controller (for example, HTBasic or Agilent VEE).
3. Other devices (other instruments and/or peripherals that serve your purpose)
4. GPIB cables for connecting the E4980A, the external controller, and other devices

Scale of the system you can construct

- You can connect up to 15 devices in a single GPIB system.
- The length of cables to make connections between devices must be 4 m or less. The total length of connecting cables in a single GPIB system must be $2 \text{ m} \times$ the number of connected devices (including the controller) or less. You cannot construct a system in which the total cable length exceeds 20 m.
- The number of connectors connected to an individual device must be four or less. If you connect five or more connectors, excessive force will be applied to the connector part, which may result in failure.
- You can choose the device connection topology from star, linear, and combined. Loop connection is not supported.

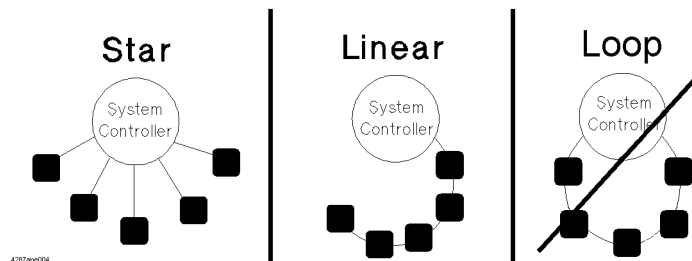

Device selector

The device selector is a unique value assigned to each device that is used by the controller to select the control target (to send/receive messages) among devices connected on the GPIB remote control system.

The device selector consists of a select code (usually, 7) and a GPIB address. For example, when the select code is 7 and the GPIB address is 17, the device selector is 717. The select code must be individually set for each system. The GPIB address must be set to a unique value for each device, and is used to identify devices on the same system. In the description and sample programs in this manual, it is assumed that the device selector is set to 717.

Setting the GPIB address of the E4980A

[System] - SYSTEM CONFIG - GPIB ADDR

LAN remote control system

The LAN (Local Area Network) remote control system provides two methods: controlling the E4980A using the SICL-LAN server and controlling the E4980A using the telnet server.

System configuration

Use a LAN cable to connect the E4980A to the external controller (computer). Figure 8-2 shows an overview of the LAN remote control system's configuration.

Figure 8-2

Configuration of the LAN remote control system

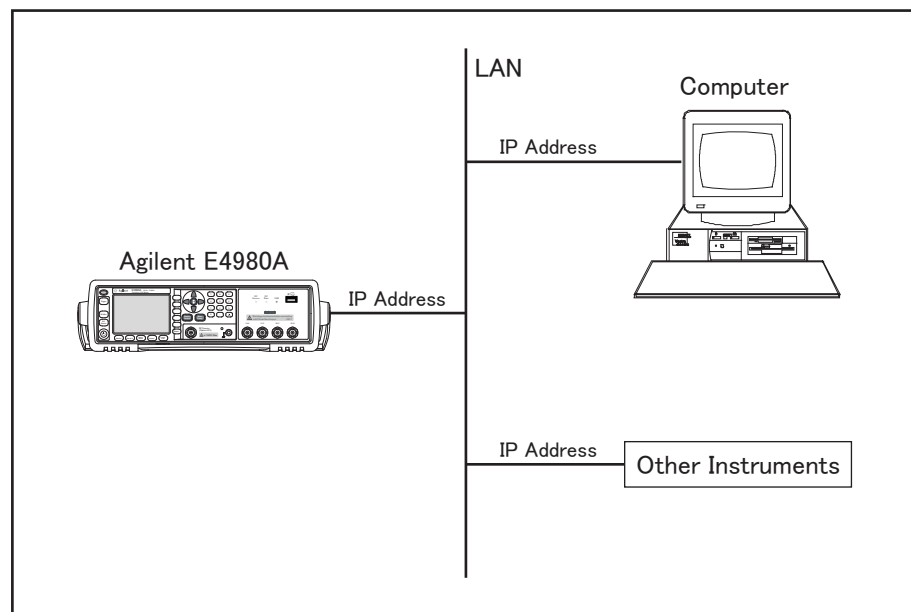

e4980aue1005

Required Equipment

1. E4980A
2. External controller (personal computer or workstation that can be connected to a LAN and with Agilent I/O Libraries Suite installed)
3. Other devices (other instruments and/or peripherals that serve your purpose)
4. LAN cable for connecting the E4980A with the external controller

Preparing the E4980A

Before controlling the E4980A via a LAN, you need to configure the network function. For detailed information on the procedure, refer to Chapter 5, "System Configurations," on page 155.

Control over SICL-LAN server

In a control system using the SICL-LAN server, communication between the external controller (client) and the E4980A (server) is performed using the SICL-LAN protocol. Communication is performed using SICL (Standard Instrument Control Library). You can control the E4980A by programming using SICL or VISA in C language in a UNIX environment, or Visual C++, Visual Basic, or VEE in a Windows environment.

Preparing the external controller

To establish communication with the E4980A using the TCP/IP protocol, you need to set the I/O interface of the external controller in advance. This section shows the setting procedure when using the external controller in the Windows environment.

- Step 1.** From your PC's Start menu, click Program - Agilent I/O Libraries Suite - Agilent Connection Expert to open the Agilent Connection Expert setting screen.
- Step 2.** In the Agilent Connection Expert setting screen, select **LAN(TCPIP0)** and then select **I/O Configuration - Add Instrument** on the menu.

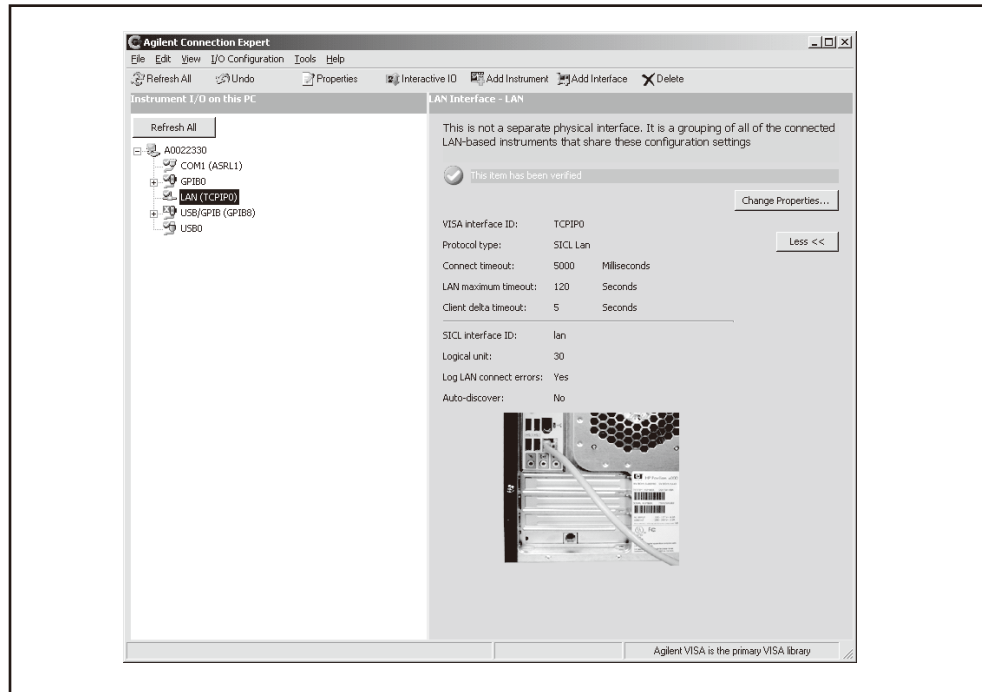

e4980auj1102

Step 3. In the Add Instrument screen, select **LAN (TCPIP0)** and click **OK**.

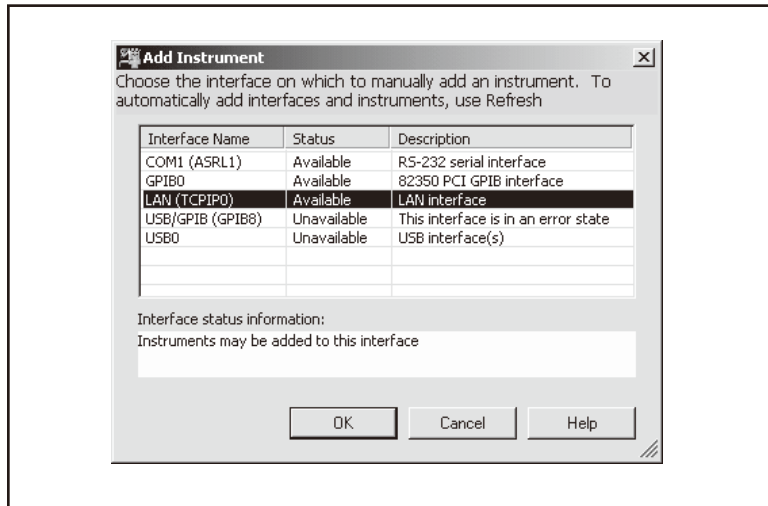

e4980auj1103

Step 4. In the LAN Instrument Properties screen, set up the IP address and click **OK**. You can change the settings as necessary. For details, refer to the Agilent I/O Libraries Suite manual.

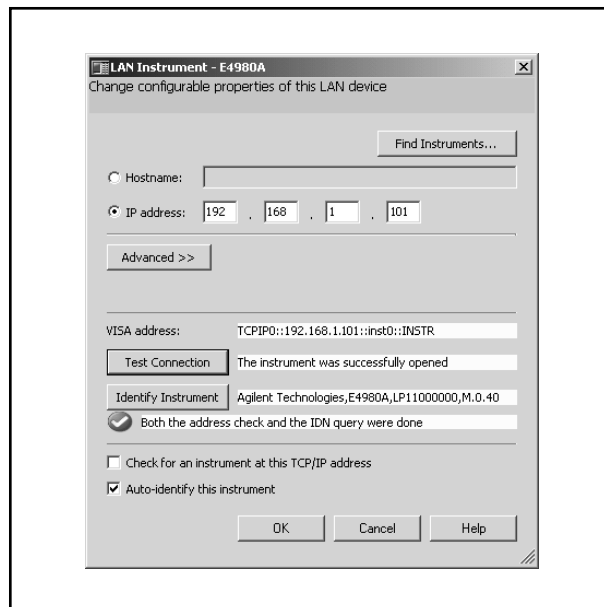

e4980auj1104

Overview of Remote Control LAN remote control system

Step 5. In the Agilent Connection Expert screen, check that the E4980A has been added.

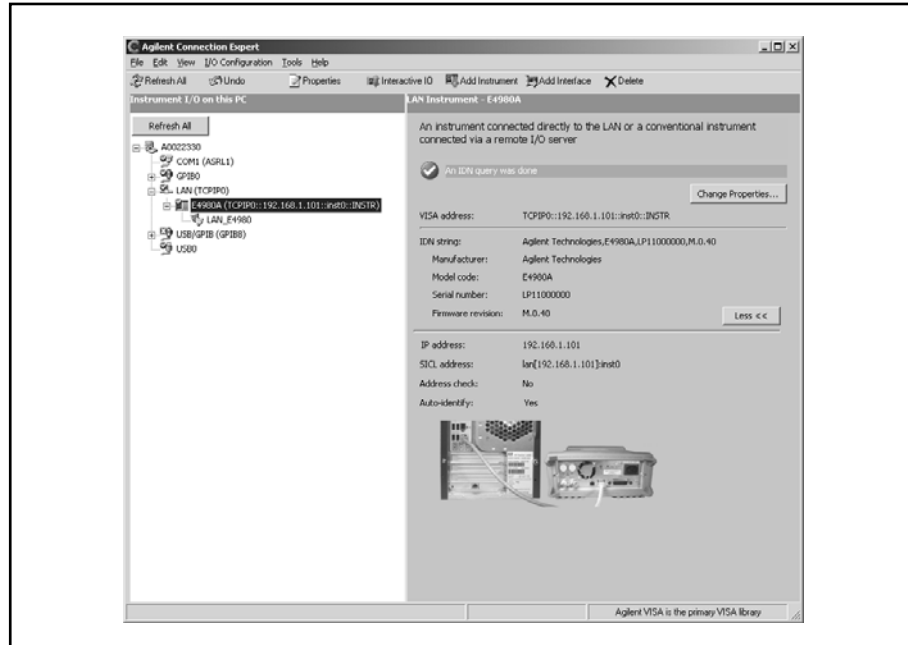

e4980auj1105

Control using C or Visual Basic

You can control the E4980A by programming using SICL/VISA in C language in a UNIX environment, or Visual C++ or Visual Basic in a Windows environment.

For more information on the control method, see a sample program using the VBA macro of Microsoft Excel described in “Section 9, Sample Program.”

Control using Agilent VEE

Agilent VEE allows you to control the E4980A via the direct I/O interface. The following example shows how to control the E4980A whose IP address is set to 192.168.1.101.

NOTE

When using Agilent VEE for PCs, use Agilent VEE Pro 6 for Windows or higher.

Step 1. On the Agilent VEE’s I/O menu, click **Instrument Manager...**

Step 2. In the Instrument Manager setting screen, click **Add...**

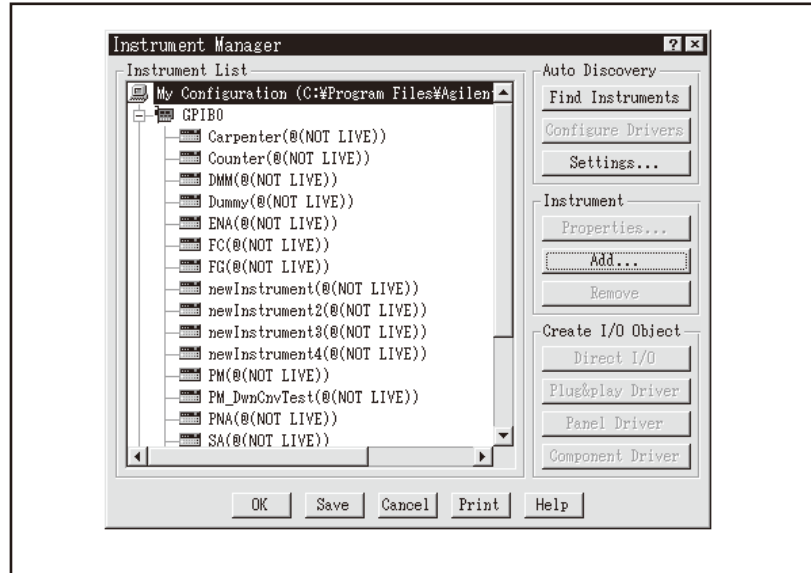

e4980auj1106

Step 3. The Instrument Properties setting screen appears. Make the settings as follows: Name: **SICL_LAN** (you can specify any name), Interface: **TCPIP**, Board Number: **0**, and TCPIP Address: **TCPIP0::192.168.1.101::inst0::INSTR**.

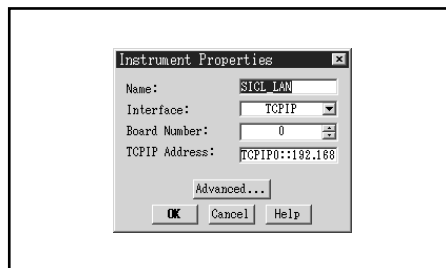

e4980auj1107

Figure 8-3 shows an example of control using the direct I/O interface that has been set in the above procedure.

Overview of Remote Control
LAN remote control system

Figure 8-3 Example of control using Agilent VEE

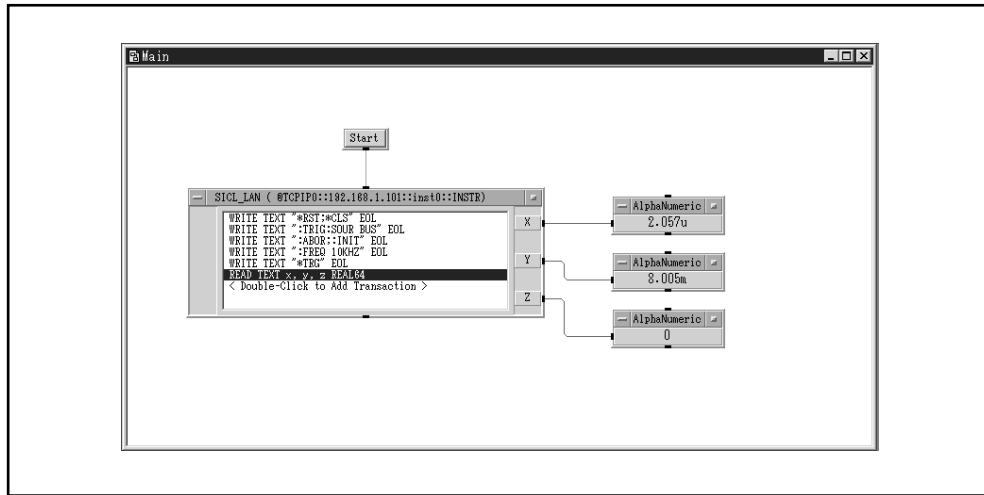

e4980auj1108

Control over telnet server

In a control system that operates over the telnet server, communications are performed through connection between the sockets provided by the processes of the external controller and the E4980A to establish a network path between them.

A socket is an endpoint for network connection; port 5024 and port 5025 are provided for the sockets for the E4980A. Port 5024 is provided for conversational control using telnet (user interface program for the TELNET protocol) and port 5025 for control from a program.

Preparing the external controller

As in the case of the SICL-LAN server, you need to set the I/O interface of the external controller in advance to establish communication to the E4980A using the TCP/IP protocol. For the procedure, refer to “Preparing the external controller” on page 230 of the “Control over SICL-LAN server” section.

Conversational control using telnet (using port 5024)

You can use telnet to perform conversational control by sending SCPI commands to the E4980A on a message-by-message basis. For telnet, the socket of port 5024 is used for communications.

NOTE

For port 5024, service requests are asynchronous. Also, use **Ctrl+C** to clear the device.

In this example, to show you the control procedure using telnet, in a Windows environment you control the E4980A (IP address: 192.168.1.101) from the external controller.

- Step 1.** Open the MS-DOS command prompt screen.
- Step 2.** At the MS-DOS prompt, type “telnet 192.168.1.101 5024” and press Enter.
- Step 3.** The telnet screen opens.
- Step 4.** Type a command and press Enter; it is sent to the E4980A and executed. If you enter a command that queries some data, the query response is displayed below the line in which you entered the command.

Figure 8-4 shows the screen displaying the measured value with :FETC? after using the :FREQ command to set measurement frequency to 10 kHz, the :FUNC:RANG:AUTO command to set the auto range setting to on, the :FUNC:IMP command to set a measurement item to Cp-D, and the *TRG command to trigger the instrument. The setting check is made with the query after each setting.

Figure 8-4

Example of control using telnet

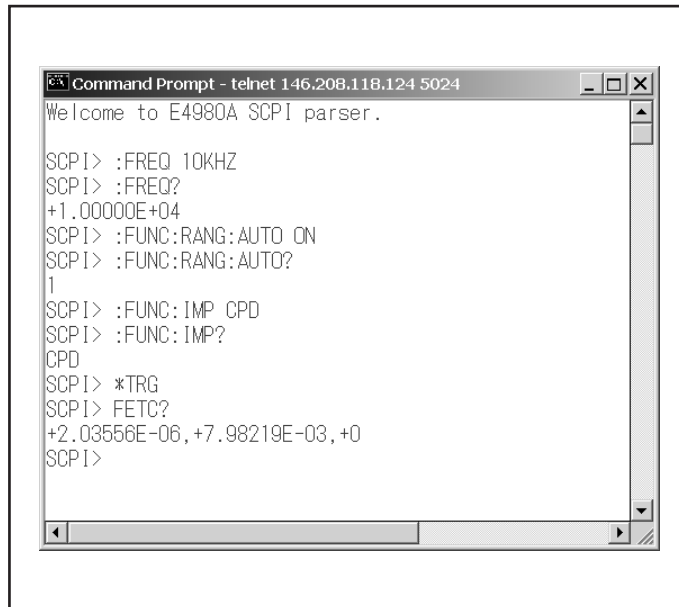

```
Command Prompt - telnet 146.208.118.124 5024
Welcome to E4980A SCPI parser.

SCPI > :FREQ 10KHZ
SCPI > :FREQ?
+1.00000E+04
SCPI > :FUNC:RANG:AUTO ON
SCPI > :FUNC:RANG:AUTO?
1
SCPI > :FUNC:IMP CPD
SCPI > :FUNC:IMP?
CPD
SCPI > *TRG
SCPI > FETC?
+2.03556E-06, +7.98219E-03, +0
SCPI >
```

e4980auj1041

Step 5. Press] while holding down Ctrl in the telnet screen to break the connection to the E4980A. The telnet prompt appears. Type “quit” at the telnet prompt and press Enter to finish using telnet.

Control from a program (using port 5025)

When controlling the E4980A from a program on the external controller, use the socket of port 5025 for connection.

Control using C or Visual Basic

You can control the E4980A by socket programming using C language in a UNIX environment, or Visual C++ or Visual Basic in a Windows environment.

For socket programming, the library for network connection on the TCP/IP protocol is required. For a UNIX environment, BSD (Berkeley Software Distribution) Sockets API is available; for a Windows environment, WinSock (WinSock1.1 and WinSock2.0), created by porting BSD Sockets to Windows and expanding it, is available.

Control using Agilent VEE

Agilent VEE allows you to control the E4980A through the connection to the socket of port 5025 using the To/From Socket. Figure 8-5 shows an example (when the IP address of the E4980A is 192.168.1.101). Enter “5025” in the field to specify the port for connection (1 in Figure 8-5) and enter the IP address of the E4980A in the field to specify the host name (2 in Figure 8-5).

Figure 8-5 Example of control using Agilent VEE

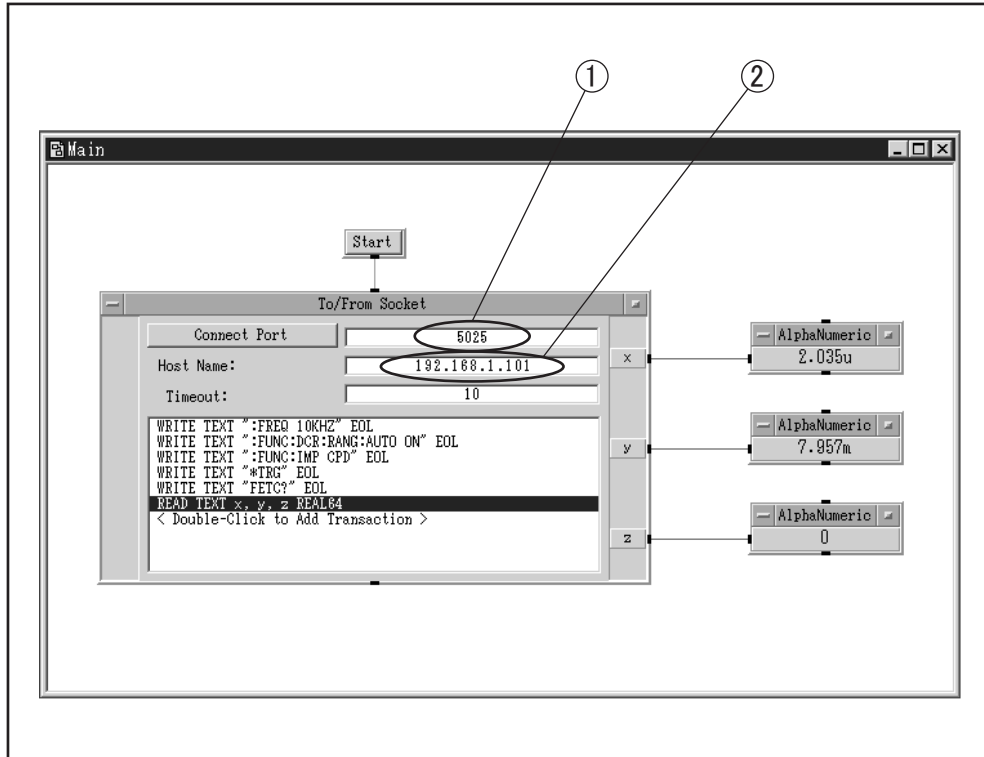

e4980auj1042

Control via Web server

For control over a Web server, communications are performed between the external controller and the E4980A through a LAN, regarding the E4980A as a Web server. You can control the E4980A and send SCPI commands from the external controller by displaying the E4980A's front panel in the external controller with Internet Explorer (IE6.0 SP2 or later).

In addition, you can import the screen and recall list measurement data.

Preparing External Controller

As in the case of the SICL-LAN server, you need to set the I/O interface of the external controller in advance to establish communication to the E4980A using the TCP/IP protocol. For the procedure, refer to "Preparing the external controller" on page 230 of "Control over SICL-LAN server" section.

Control using web server

The following steps show how to control the E4980A (IP address example: 146.208.118.171) using Internet Explorer.

Step 1. Start Internet Explorer.

Step 2. Type `http://146.208.118.171/` in the address field and press the enter key.

Enter CURRENT IP ADDR on the E4980A's SYSTEM CONFIG page for an IP address.

Step 3. The Web server's start screen appears.

Figure 8-6

Web Server Start Screen



e4980auj3001

Web Server Function

The Web Server function consists of the following pages.

Page	Description
Welcome Page	Displays various setting information
Browser Web Control	Virtual front panel and sending/reading SCPI commands
View & Modify Configuration	Displays and modifies various setting information
Get Image	Receives images
Get Data	Receives test results
Print Display	Calls the printing function of the browser
Help with this Page	Displays the Help file

NOTE To use the Web Server, refer to “Help with this Page.”

Password of Web Server Function

For the Web Server function, a password must be entered when the following operation is performed.

The default password is “agilent”.

- When pressing the Modify Configuration button on the View & Modify Configuration page.
- When moving to the Browser Web Control page from a certain page.
- When moving to the Get Data page from a certain page.

Figure 8-7

Password Entry Screen



e4980auj3002

Changing the Password of the Web Server Function

You can change the password of the Web Server function.

NOTE

The password must contain four to eight alphanumeric characters.

- Step 1.** Press the Modify Configuration button on the View & Modify Configuration page to enter the current password.
- Step 2.** Enter the current password and new password (twice) in the “Change Password” line.
- Step 3.** Press the Save button.

NOTE

You don't have to press either “Renew LAN Settings” or “Reboot E4980A.”

USB Remote Control System

The USB (Universal Serial Bus) remote control system provides device control via USB, which is equivalent to control via GPIB. Connection is made through an interface in compliance with USBTMC-USB488 and USB 2.0.

USBTMC (USB Test & Measurement Class) is a protocol whose design is based on USB for communication with a USB device, such as that via GPIB.

System configuration

The USB remote control system controls instruments that use the name “alias.” There is no such address for GPIB connections.

Use a USB cable to connect the E4980A to an external controller (personal computer). Figure 8-8 shows an overview of the system configuration for the USB remote control system

Figure 8-8

Configuration of the USB Remote Control System

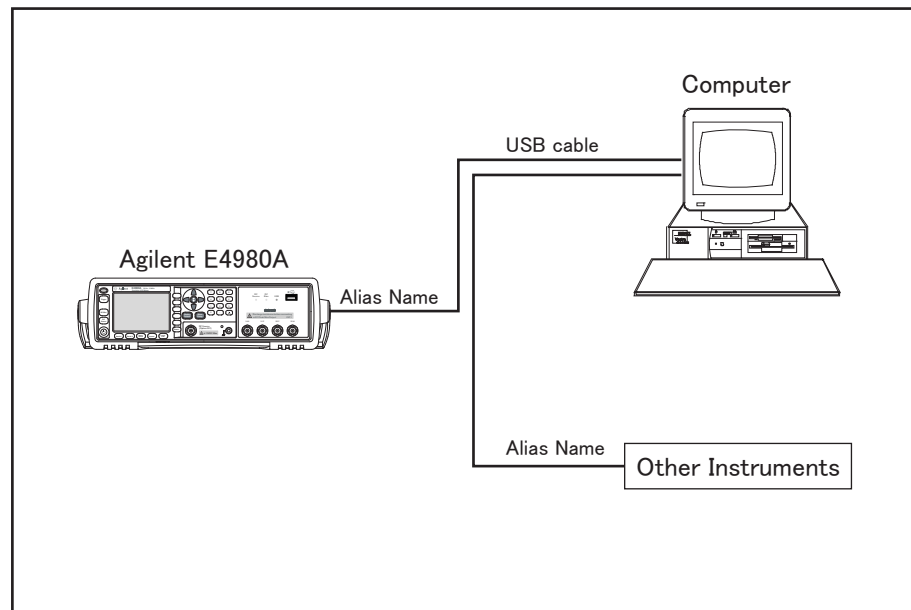

e4980aue1006



Required Equipment

1. E4980A (models with USB interface port (type mini-B)).
2. External controller (personal computer with Agilent I/O Libraries Suite and USB host port (type A)) installed.
3. Other USB-compatible devices (instruments and/or peripherals for specific purposes).
4. USB cable for connecting the E4980A to the external controller (with type A/4-prong male or type mini-B/5-prong male connectors, depending on device used).

Overview of Remote Control USB Remote Control System

USB Port Types

There are two standard types of USB ports. The external controller (PC) must be connected via the USB host port (type A), while the E4980A and other USB-compatible devices must be connected via the USB interface port (type mini-B).

	Type A: USB host port
	Type mini-B: USB interface port

Preparing E4980A

You do not have to configure any softkey or command for the E4980A in order to control the E4980A from an external controller. Simply connect a USB cable to the USB interface port.

Preparing External Controller

You must set up the I/O interface of the external controller in advance to establish communication with the E4980A via a USB. The USB can identify devices automatically, so once you connect a USB cable to a target device, a dialog box will appear for USB device registration.

NOTE

The E4980A will be identified as a new device if its serial number has been changed.

1. Registering Alias When USB Cable is Connected

When new device is connected via USB cable, the following dialog box will appear automatically. Follow the steps below to register an alias when you use Agilent I/O Libraries Suite 14.

Step 1. In the Assign USB device alias dialog box, enter an alias and then click **OK**.

Figure 8-9

Registering Alias

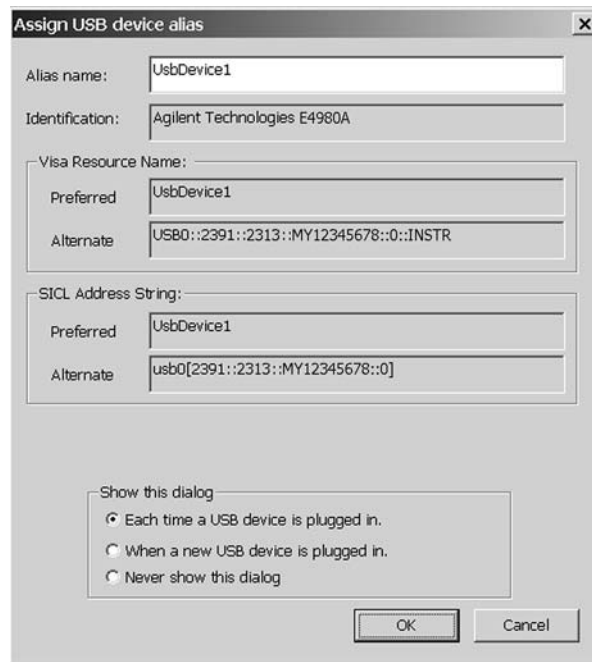

e4980auj1009

NOTE

For an alias, use the ASCII format and less than 127 digits. The alias is upper/lower case insensitive.

If the “Never show this dialog” is selected in the “Show this dialog” frame, the dialog box will not appear even if a new device is connected.

NOTE

Once a new device is identified, the “New Hardware Search Wizard” will start. Follow the instructions to implement the processing.

2. Changing Alias on Setting Screen

The following are steps using Agilent I/O Libraries Suite 14.

Step 1. From your PC’s Start menu, click Program - Agilent IO Libraries Suite -Agilent Connection Expert to open the setting screen.

Step 2. In the setting screen, select the alias names from **USB0** onward in the **Instrument I/O on this PC** frame, and then select the **Change Properties** from **I/O Configuration** on the menu bar.

Figure 8-10 Changing Alias

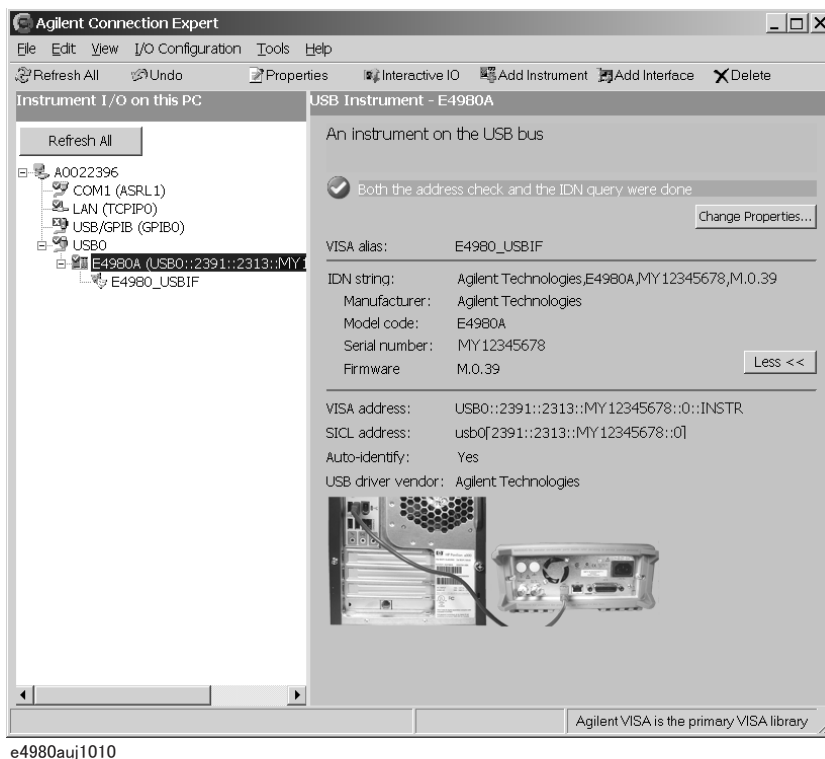

Step 3. Change the VISA alias in the VISA Alias dialog box and press **OK**.

Figure 8-11

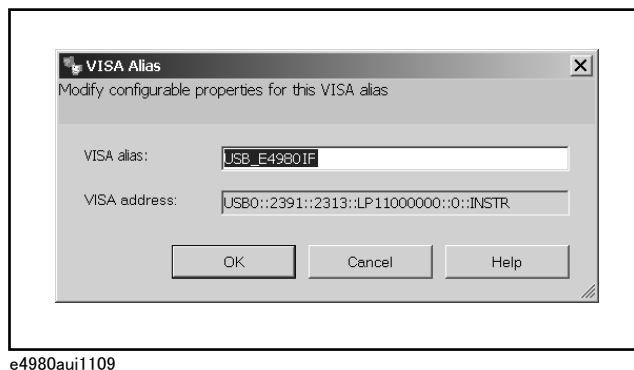

Control using C or Visual Basic

You can control the E4980A by programming using SICL/VISA with Visual C++ or Visual Basic in a Windows environment. For further information on controlling the E4980A, see the manual for SICL or VISA. For Agilent I/O Libraries Suite, use Agilent I/O Libraries Suite 14.

You may employ aliases in programming using SICL/VISA.

The following example shows an OPEN command to control the E4980A, for which the alias is E4980_USBIF.

SICL	id = iopen ("E4980_USBIF")
VISA	viOpen (...,"E4980_USBIF",...)

NOTE

For further details on the programming using SICL/VISA, see the SICL Users Guide or the VISA Users Guide.

Overview of Remote Control USB Remote Control System

Control using Agilent VEE

Agilent VEE allows you to control the E4980A via the direct I/O interface. The following example shows how to control the E4980A, for which alias is given as E4980_USBIF.

NOTE When using Agilent VEE for PCs, use Agilent VEE Pro 7 for Windows or a later version.

- Step 1.** On the Agilent VEE's **I/O** menu, click **Instrument Manager...**
- Step 2.** In the Instrument Manager setting screen, click **Add...** and in the Add Interface/Device screen select **USB**.

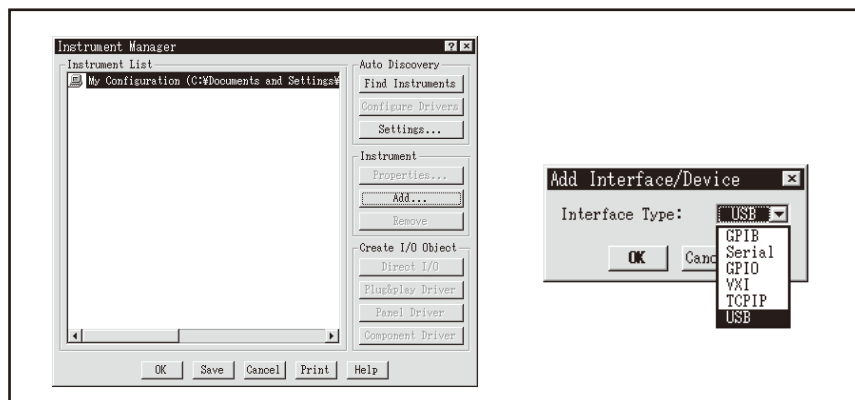

e4980auj1111

- Step 3.** The Instrument Properties dialog box appears. Specify Name: **E4980_USBIF**(any other name acceptable), Interface: **USB**, Board Number: **0** (USB port number), and Alias: **E4980_USBIF** (which is registered in the IO Config setting screen), then click **OK**.

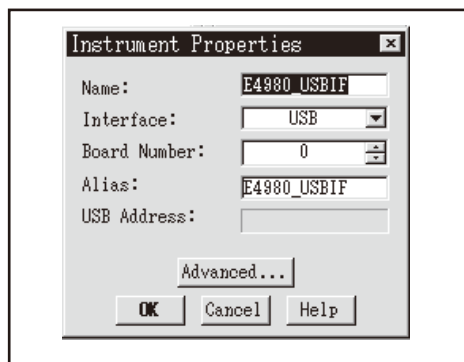

e4980auj1112

Figure 8-12 shows an example of control using the direct I/O interface that was set in the above procedures.

Figure 8-12 Sample Control Using Agilent VEE (USB)

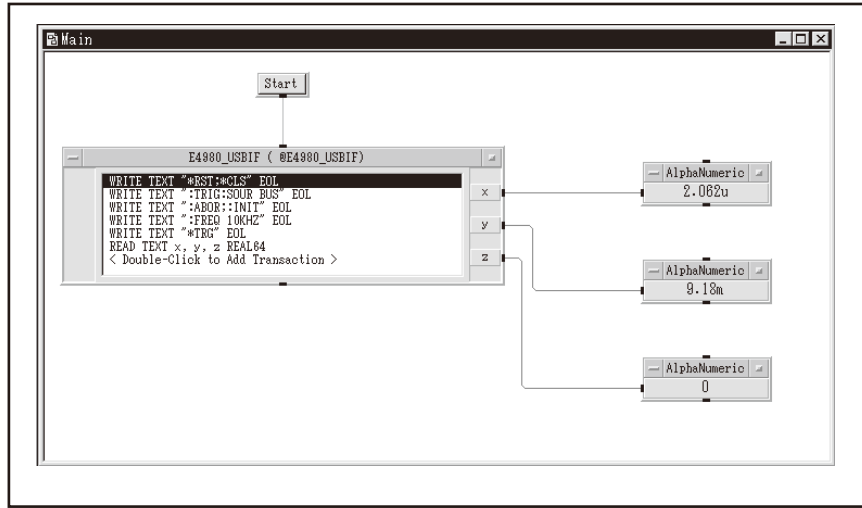

e4980auj1113

8. Overview of
Remote Control

Sending SCPI command messages

Types and structure of commands

The SCPI commands available for the E4980A are classified into two groups as follows.

E4980A commands

Commands specific to the E4980A. They cover all measurement functions that the E4980A has and some general-purpose functions. The commands in this group are arranged in a hierarchical structure called the command tree (see “Command Tree” on page 343). Each command consists of character strings (mnemonics) indicating each hierarchical level and colon (:) separators between hierarchical levels.

IEEE common commands

Commands to cover general-purpose functions defined in IEEE488.2 that are commonly available to instruments that support this standard. The commands in this group have an asterisk (*) at the beginning. There is no hierarchical structure for the commands in this group.

Concepts of the command tree

The commands at the top of the command tree are called “root commands” or simply “roots.” To access lower-level commands in the tree, you need to specify a specific path like a directory path in the DOS file system. After turning the power on or resetting your PC, the current path is set to the root. Special characters in messages change the path setting as described below.

- Message terminator A message terminator such as the
<new line> character sets the current path to the root.
- Colon (:) A colon between two command mnemonics lowers the level of the current path in the command tree. A colon used as the first character of a command specifies the command mnemonic that follows as the root-level command.
- Semicolon (;) A semicolon does not change the current path but separates two commands in the same message.

Figure 8-13 shows an example of how to use colons and semicolons to efficiently access commands in the command tree.

Figure 8-13

Using colons and semicolons

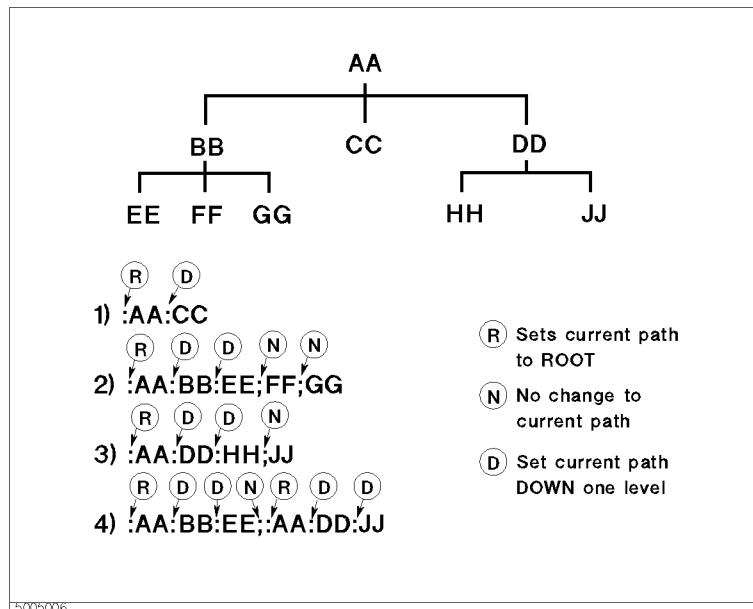

Grammar of messages

This section describes the grammar to send program messages via GPIB. Program messages are messages that the user sends to the instrument from the external controller to control the instrument. A program message consists of one or more commands and their necessary parameters.

Upper/lower case sensitivity

Upper/lower case insensitive.

Program message terminator

A program message must be terminated with one of the three program message terminators: <new line>, <^END>, or <new line><^END>. <^END> indicates that EOI on the GPIB interface becomes active at the instant when the immediately previous data byte is sent. For example, the OUTPUT command of HTBasic automatically sends the message terminator after the last data byte.

Parameters

A space (ASCII code: 32) is required between a command and its first parameter. When sending several parameters in a single command, separate each parameter with a comma (,).

Message including several commands

When sending two or more commands in a single message, separate each command with a semicolon (;). The following example shows how to send the *CLS command and the :STAT:PRES command in a single message using HTBasic.

```
OUTPUT 717; "*CLS; :STAT:PRES"
```

Remote mode

The E4980A enters remote mode when controlled with commands from the controller and **RMT** is displayed in the status display area in the lower right of the screen.

Press [**Local/Lock**] to cancel the remote mode.

NOTE

When the E4980A enters a local lockout state by sending the LOCAL LOCK BUS command from the controller, you cannot unlock the remote mode even if you press [**Local/Lock**]. (Only **RMT** is displayed in the status display area, so you cannot distinguish the local lockout state from a normal remote mode.)

Send the LOCAL BUS command from the controller to cancel this state, which enables control of the E4980A on the front panel.

Trigger System

The trigger system is responsible for such tasks as detecting the start of a measurement cycle (triggering) and controlling the system state. As Figure 8-14 shows, the trigger system has a system-wide state that can be “Idle,” “Waiting for Trigger,” or “Measurement.”

Figure 8-14

Trigger system

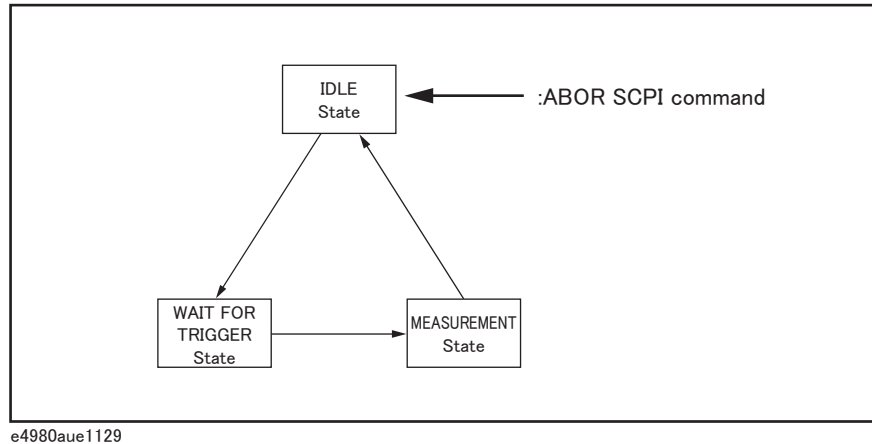

The following subsections describe each state and explain how the trigger system switches among the states.

System-wide states and transitions

“Idle” State

The trigger system switches to “Idle” state when one of the following commands has been executed. In the “Idle” state, measurement data and monitor data can be read with query commands of the :FETCh subsystem. Also, turning on the power to the instrument puts the trigger system into “Idle” state. When the power is turned on, however, the continuous initiation mode is on and the trigger source is set to “Internal”; accordingly, the trigger system immediately switches to the “Waiting for Trigger” state and subsequently repeats transitions between the “Measurement” and “Waiting for Trigger” states.

- :ABOR
- *RST
- Other commands to change settings (:FREQ, etc.)

When the DC bias function is turned on, the trigger system switches to the “Idle” state.

When starting the trigger system with one of the following commands, the system switches from “Idle” to the “Waiting for Trigger” state. The conditions of transition differ depending on which trigger source is specified (Refer to Figure 8-16 on page 255 and Figure 8-17 on page 256).

- :INIT[:IMM]
- :INIT:CONT

Overview of Remote Control Trigger System

When the trigger source is set to the external trigger (EXT), the conditions for switching from “Idle” to “Waiting for Trigger” differ between the remote mode and local mode.

Remote mode	When the :INIT:CONT is ON, the trigger system automatically switches to “Waiting for Trigger.” When the :INIT:CONT is OFF, the trigger system switches to the “Waiting for Trigger” state by sending the :INIT:IMM command.
Local mode	The trigger system automatically switches from “Idle” to “Waiting for Trigger.”

When the trigger source is set to the internal trigger (INT) or manual trigger (MAN), the trigger system automatically switches from the “Idle” state to the “Waiting for Trigger” state.

NOTE

The E4980A in the “Idle” state switches to the “Measurement” state by using the :TRIG command.

When the :ABOR command is executed, the trigger system switches to the “Idle” state regardless of which state the E4980A is currently in. An error occurs when query commands of the :FETCh subsystem are executed because no measurement data exist.

“Waiting for Trigger” State

When the trigger system is in the “Waiting for Trigger” state and either the instrument is triggered (i.e., a trigger is detected) or one of the following commands is executed, the trigger system switches to the “Measurement” state.

- :TRIG

As shown in the table below, the instrument is triggered differently depending on which trigger source is specified. To specify the trigger source, use the :TRIG:SOUR command.

Trigger Source	How instrument is triggered
Internal trigger (Internal)	The instrument is automatically triggered within itself.
External trigger (External)	The instrument is triggered when a trigger signal is input through the external trigger terminal, the handler I/O port, or the scanner I/O port.
Bus trigger (Bus)	The instrument is triggered when the *TRG command or TRIGGER (GET) bus command is issued.
Manual trigger (Man)	The instrument is triggered when you press [Trigger] on the front panel.

NOTE

When the sweep averaging function is on, even if the instrument is set so that the trigger is detected for each sweep, the sweep is performed repeatedly until the sweep averaging for a specified number of times finishes. This is done by triggering the instrument once at the beginning or executing the : TRIG command.

There are three kinds of trigger commands: the *TRG common command, the TRIGGER (GET) bus command, and the :TRG GPIB command. These commands are classified into

two types in this trigger system. (Refer to Figure 8-15).

Figure 8-15 Trigger system and trigger commands

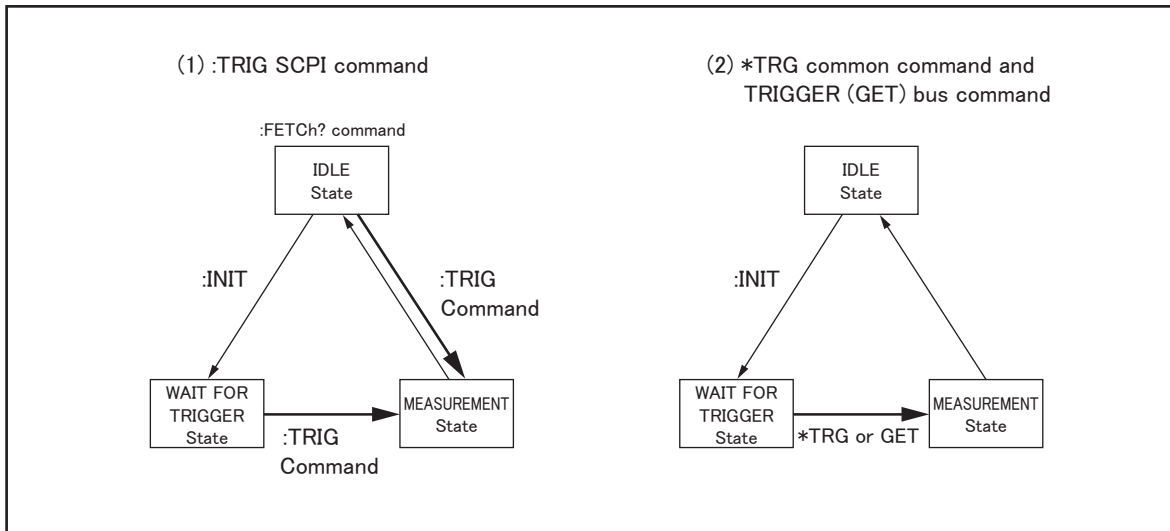

e4980aue1130

1. :TRIG GPIB command

When the trigger system is either in the “Waiting for Trigger” or “Idle” state, the E4980A is triggered by sending the :TRIG command. When reading measurement results via a controller in the “Idle” state, you need to use the :FETCh? query command.

2. *TRG command or TRIGGER (GET) bus command

In the “Waiting for Trigger” state, the E4980A is triggered by sending the *TRG command or the TRIGGER (GET) bus command, and measurement results in one trigger sequence can be read without sending the :FETCh? query command in the “Idle” state.

Therefore,

"*TRG" = ":TRIG;;FETCh?"

The following two sample programs show the difference between the :TRIG command and the *TRG commands.

```

10 ASSIGN @Adrs TO 717
20 REMOTE @Adrs
30 OUTPUT @Adrs;"*RST;*CLS"
40 OUTPUT @Adrs;":TRIG:SOUR BUS"
50 OUTPUT @Adrs;":ABOR;:INIT"
60 OUTPUT @Adrs;":TRIG"
70 OUTPUT @Adrs;":FETCh?"
80 ENTER @Adrs;A,B,C
90 END

10 ASSIGN @Adrs TO 717
20 REMOTE @Adrs
30 OUTPUT @Adrs;"*RST;*CLS"
40 OUTPUT @Adrs;":TRIG:SOUR BUS"
50 OUTPUT @Adrs;":ABOR;:INIT"
60 OUTPUT @Adrs;"*TRG"
70 ENTER @Adrs;A,B,C

```

Overview of Remote Control Trigger System

80 END

Measurement State

In the “Measurement” state, the instrument waits for the sweep delay time to elapse when it is specified and then starts a measurement cycle (sweep).

When the instrument finishes measurement, the trigger system behaves in one of the following ways depending on the setting of the continuous initiation mode.

If the continuous initiation mode is off:

The trigger system switches to the “Idle” state

If the continuous initiation mode is on:

The trigger system switches to the “Idle” state and then automatically switches to the “Waiting for Trigger” state

NOTE

When the E4980A is in remote mode, measurements can be made only on the screen displayed by pressing **[Display Format]**.

A typical flowchart of data transfer using the trigger system is shown below.

Figure 8-16 Trigger system and data transfer (INT/MAN)

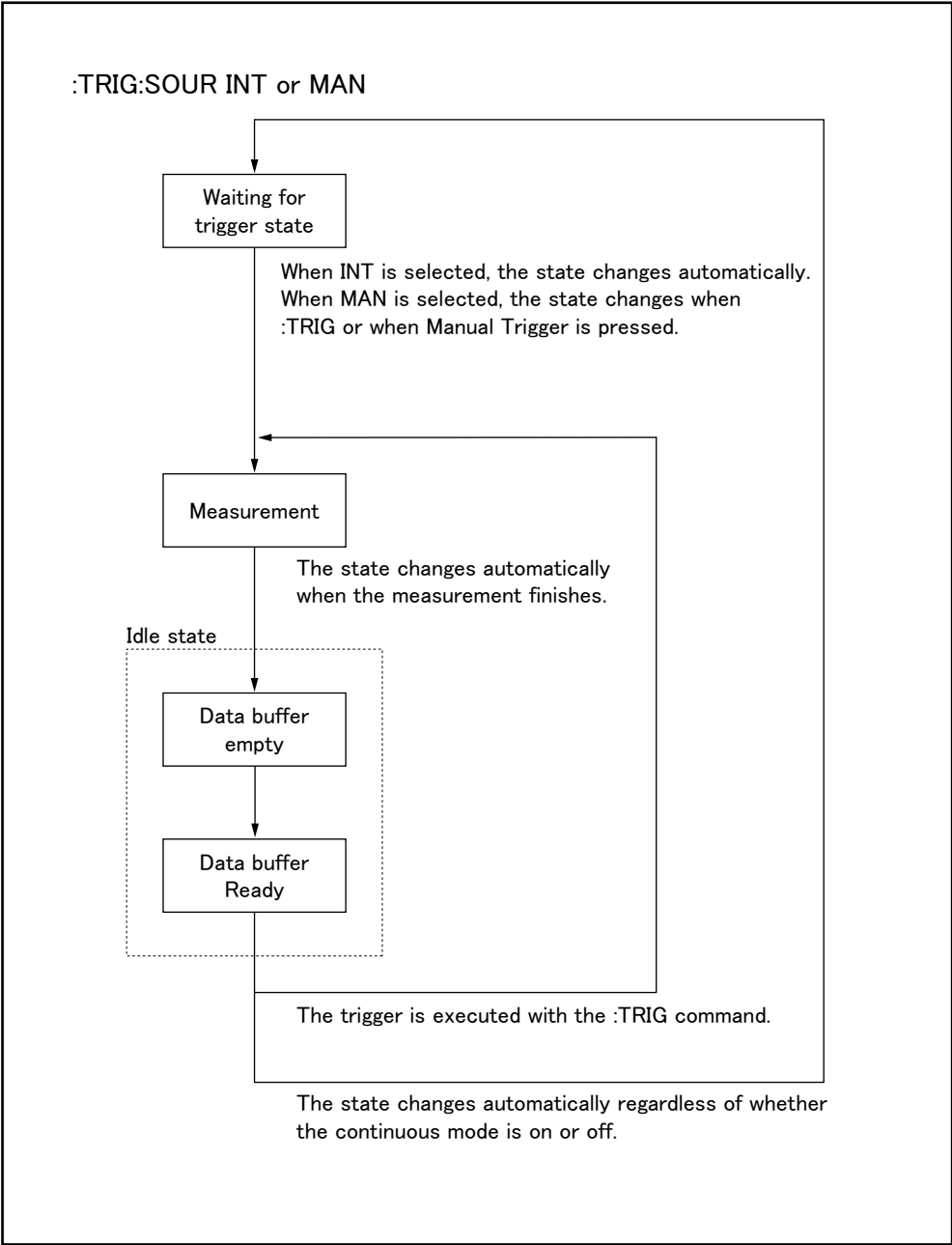

e4980aue1043

8. Overview of Remote Control

Figure 8-17 Trigger system and data transfer (EXT/BUS)

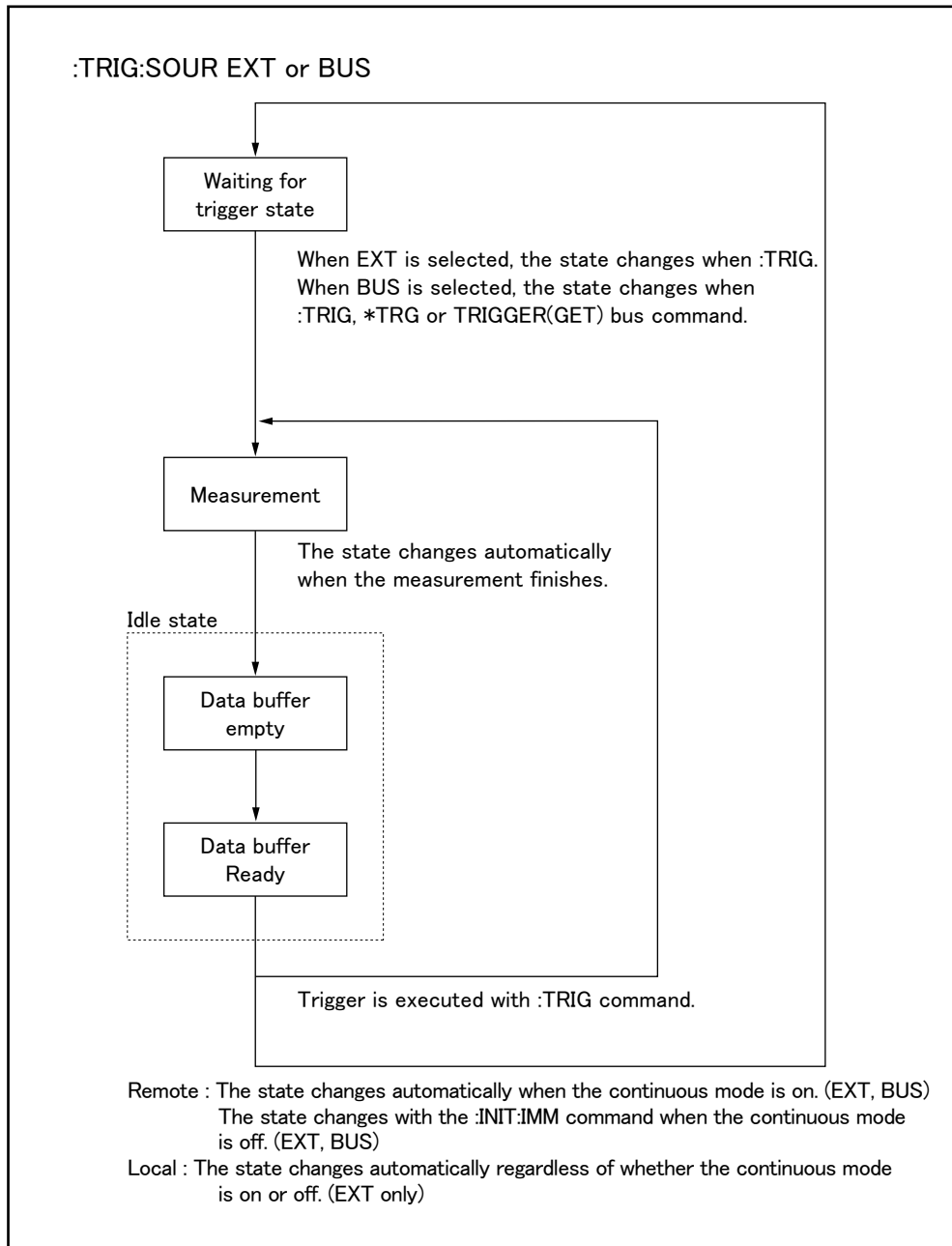

NOTE

When the E4980A is set to the external trigger mode, and is triggered via the external trigger input terminal or an optional interface, this trigger signal has the same effect as the :TRIG command.

Data Buffer Memory

Data Buffer Memory

The E4980A has a data buffer memory function. The data buffer memory can hold up to 201 sets of measurement results, and all buffered measurement results are transferred at once to the controller by using the :MEM:READ? DBUF command. This function makes it possible to greatly reduce the overall time for data transfer.

Refer to the following figure. Line numbers in the figure correspond to those of the reference codes below the figure.

Figure 8-18 Data buffer memory

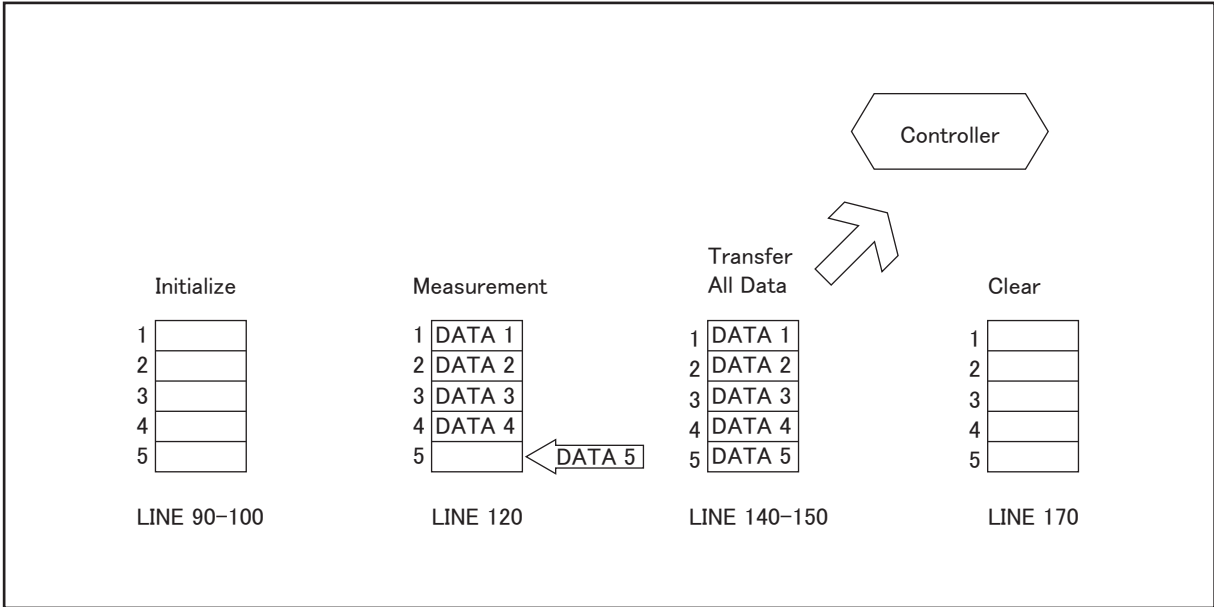

e4980aue1019

```

10  OPTION BASE 1
20  DIM D(5,4)
30  ASSIGN @Adrs TO 717
40  REMOTE @Adrs
50  OUTPUT @Adrs;"*RST;*CLS"
60  OUTPUT @Adrs;"FORM ASCII"
70  OUTPUT @Adrs;"TRIG:SOUR BUS"
80  OUTPUT @Adrs;"DISP:PAGE MEAS"
90  OUTPUT @Adrs;"MEM:DIM DBUF,5"
100 OUTPUT @Adrs;"MEM:FILL DBUF"
110 FOR I=1 TO 5
120   OUTPUT @Adrs;"TRIGGER:IMMEDIATE"
130 NEXT I
140 OUTPUT @Adrs;"MEM:READ? DBUF"
150 ENTER @Adrs;D(*)
160 PRINT D(*)
170 OUTPUT @Adrs;"MEM:CLE DBUF"
180 END

```

8. Overview of Remote Control

When Data Buffer Memory is Used

Follow the rules below when using the data buffer memory function.

- o Measurement data collected after sending the :MMEM:FILL DBUF command to use the data buffer memory function are stored in the data buffer memory in the order measured.
- o When the E4980A is triggered using the :TRIG command, the measurement results are stored only in the data buffer memory. Therefore, you do not have to clear the output buffer after each measurement.

*When the E4980A is triggered using the *TRG or TRIGGER (GET) bus command, the measurement results are stored in both the data buffer memory and the output buffer. Therefore, it is necessary to read the measurement results in the output buffer using the controller and to clear the output buffer each time a measurement is made. If you fail to do this, an error (-410, "Query INTERRUPTED") will occur.

The output buffer is the area where measurement data are stored when the E4980A is triggered without using the data buffer memory. The data buffer memory is off in the E4980A's initial state, and measurement data are stored in the output buffer. It is necessary to read data in the output buffer using the controller and clear the output buffer each time a measurement is made.

- o When the number of sets of measurement data exceeds the capacity of the buffer memory, all of the overflowed measurement data will be lost, an error (90, "Data Memory Overflow") will occur, and bit 3 of the standard event status register will be set to 1. When you store new data into the buffer data memory, use the :MEM:CLE DBUF command to clear the data buffer memory.
- o When the number of sets of measurement data is less than the capacity of the buffer memory, the following data, instead of the actual measurement data, are input to the unused portion of the data buffer memory.

Data A	9.9E37
Data B	9.9E37
Status	-1
BIN No. or IN/OUT	0

- o When the data buffer memory function is used during a list sweep measurement, the measurement result for one sweep point is stored as one set of measurement data. Therefore, when two or more sweep points are the same and are adjacent, the E4980A measures the device once, but the number of data sets stored in the data buffer memory is equal to that of the sweep points.
- o When the list sweep measurement's limit function is set to off at a sweep point, IN/OUT is 0. Also, when the comparator function is set to off, the BIN No. is 0.

Output Format of Data Buffer Memory

There are two formats returned by the :MEM:READ? DBUF command: ASCII and BINARY. Each format is described below. For sample programs using the data buffer memory (output format: ASCII and BINARY), refer to the chapter on sample programs.

- o ASCII Format

Figure 8-18 below shows the output format when the ASCII format is selected as the data format. The data format and meaning of <DATA A>, <DATA B>, <STATUS>, <BIN No.>, or <IN/OUT> are the same as those of the ASCII data format described in Data Format of “Data Transfer” on page 265

Figure 8-19 ASCII format (Buffer memory)

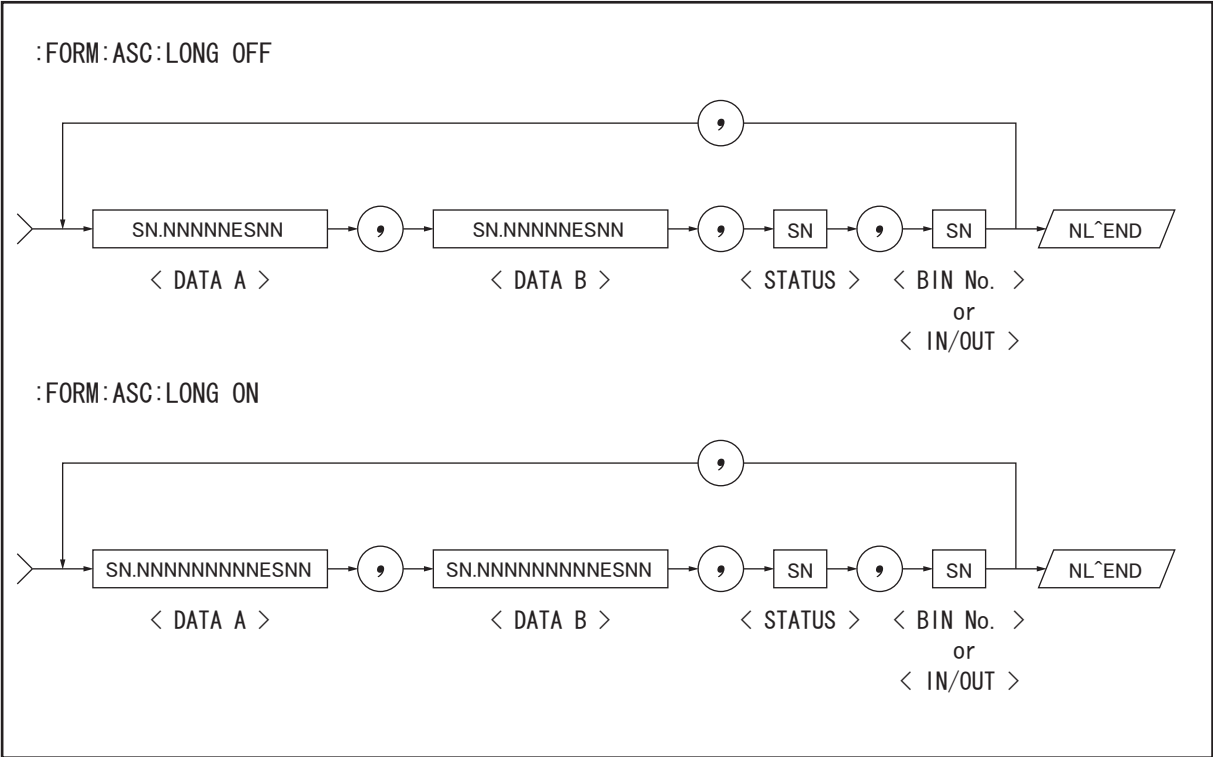

e4980aue1020

- o BINARY Format

Figure 8-19 shows the output format when the BINARY format is selected as the data format. The data format and meaning of <DATA A>, <DATA B>, <STATUS>, <BIN No.>, or <IN/OUT> are the same as those of the BINARY data format described in Data Format of “Data Transfer” on page 265

8. Overview of Remote Control

Figure 8-20 Binary format (Buffer memory)

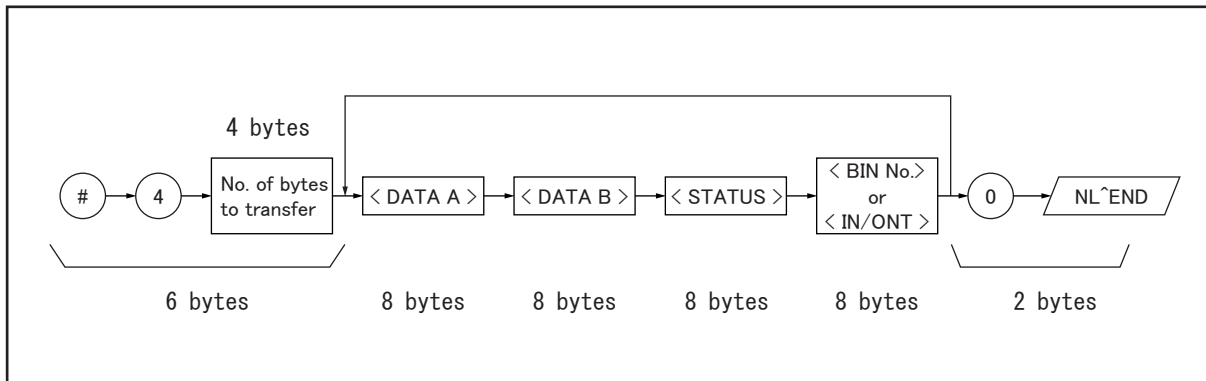

e4980aue1021

NOTE

NL^END is not included in the number of bytes to transfer. For example, the number of byte of “:MEM:DIM DBUF, 3”, is $(8 \times 4) \times 3 + 1 = 97$ bytes.

Starting a Measurement Cycle (triggering the instrument)

Configuring the instrument to automatically perform continuous measurement

- Step 1.** When the trigger system does not run (“Idle” state), use the :INIT:CONT command to turn on the continuous initiation mode.
- Step 2.** Issue the :TRIG:SOUR command to set the trigger source to the internal trigger.

Starting Measurement on Demand

There are two ways to start measurement on demand.

Trigger the instrument to start measurement when the trigger system is in the “Waiting for Trigger” state

Put the E4980A in the “Waiting for Trigger” state and start measurement whenever you want. In cases where it takes some time to obtain stable measurement values, a controller can control the timing for triggering.

Follow the steps below.

- Step 1.** When the trigger system is not operating (“Idle” state), use the :INIT:CONT command to turn on the continuous initiation mode.
- Step 2.** Issue the :TRIG:SOUR command to set the trigger source to “Bus Trigger.”
- Step 3.** Trigger the instrument whenever you want to perform measurement. An external controller can trigger the instrument with one of the following two commands:

Command	Applicable trigger source
*TRG	Bus trigger only
:TRIG	External trigger Bus trigger Manual trigger

- Step 4.** Repeat Step 3 to start the next measurement cycle.

Obtaining measurement data on demand while continuous sweep is performed

Start measurement whenever you want while the E4980A performs continuous measurement.

Follow the steps below.

- Step 1.** When the trigger system is operating (any state other than “Idle”), abort the trigger system using the :ABOR command.
- Step 2.** Issue the :TRIG:SOUR command to set the trigger source to “Internal Trigger.”
- Step 3.** The trigger system starts, and the instrument is automatically triggered by the internal

Overview of Remote Control

Starting a Measurement Cycle (triggering the instrument)

trigger, performing continuous measurement.

Step 4. Read measurement data on demand.

NOTE

For the list sweep measurement, the method of triggering the instrument differs depending on the list sweep mode.

Use the `:LIST:MODE SEQ|STEP` command to change the list sweep mode.

1. Sequential mode

When the E4980A is triggered once, the device is measured at all sweep points.

2. Step mode

The sweep point is incremented each time the E4980A is triggered.

Figure 8-21 Sequential mode and step mode

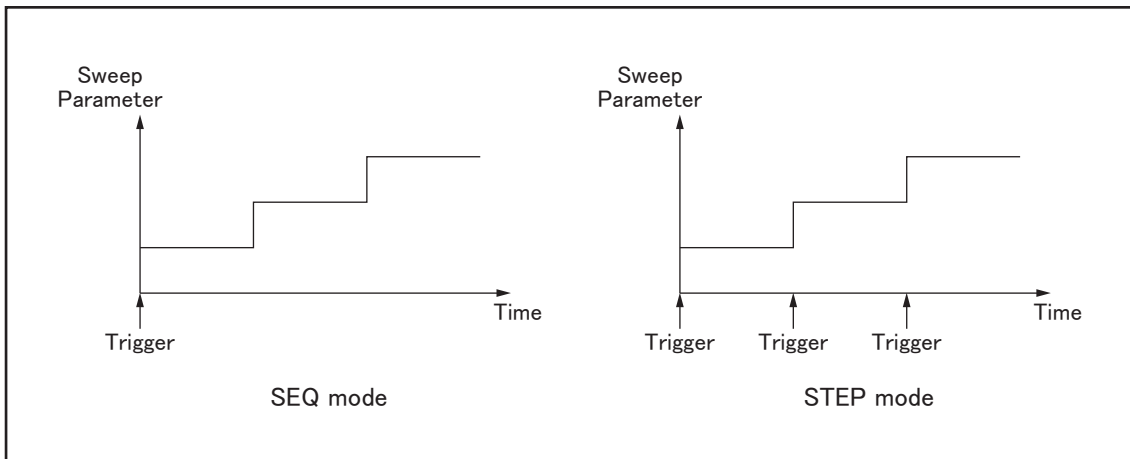

e4980aue1066

Waiting for the End of Measurement

Using the status register

The E4980A's status can be detected through the status registers. This section explains how to use the status registers to detect the end of measurement. For a complete description of the status report mechanism, including the specifications of each bit, see "Status Byte" on page 271.

The measurement status is reported by the operation status event register. An SRQ (service request) is convenient for detecting the end of measurement. It uses the information reported by this register.

To detect the end of measurement via an SRQ, use one of the following commands:

- *SRE
- :STAT:OPER:ENAB

Follow these steps to use an SRQ.

- Step 1.** Configure the E4980A so that it generates an SRQ when the operation status event register's bit (a bit that is set to 1 during measurement) is changed from 1 to 0.
- Step 2.** Trigger the instrument to start a measurement cycle.
- Step 3.** When an SRQ is generated, the program interrupts the measurement cycle.

NOTE

When the sweep averaging function is on, the E4980A generates an SRQ when it has finished taking a number of measurements that is equal to the sweep averaging number.

Overview of Remote Control
 Waiting for the End of Measurement

Figure 8-22 Sequence generating SRQ (end of measurement)

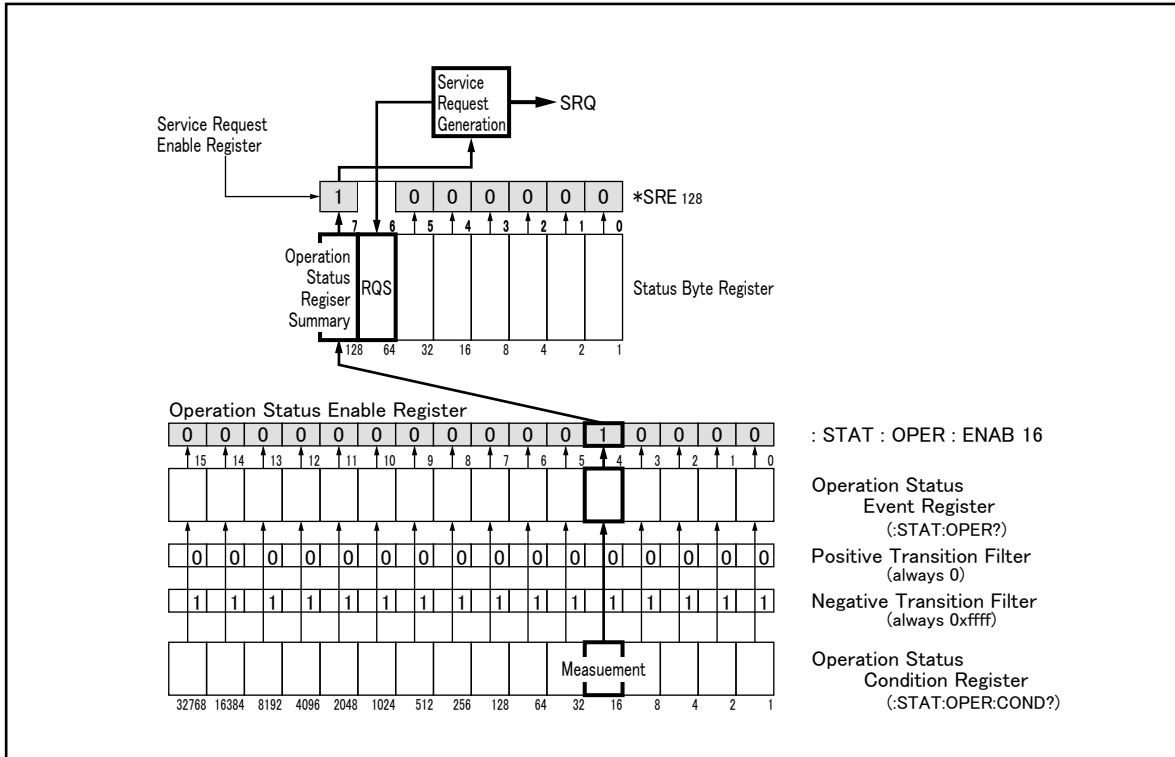

e4980aue1126

Data Transfer

This section describes data transfer.

Data Format

The E4980A offers two data formats for GPIB data transfer to the controller, ASCII and BINARY. Data transfer rates vary depending on the data format used.

ASCII Format

The ASCII data format is the default output format. When the :FORM:DATA ASC command is executed, the E4980A transfers data in the ASCII format. The ASCII format of the E4980A has two modes: the six-significant-digit mode and the ten-significant-digit mode. The six-significant-digit mode is the default, though the format can be switched to the ten-significant-digit mode by using the :FORM:ASC:LONG ON command. The ASCII data output format on the MEAS DISPLAY, BIN No., or BIN COUNT page is described below.

Figure 8-23 ASCII Format 1

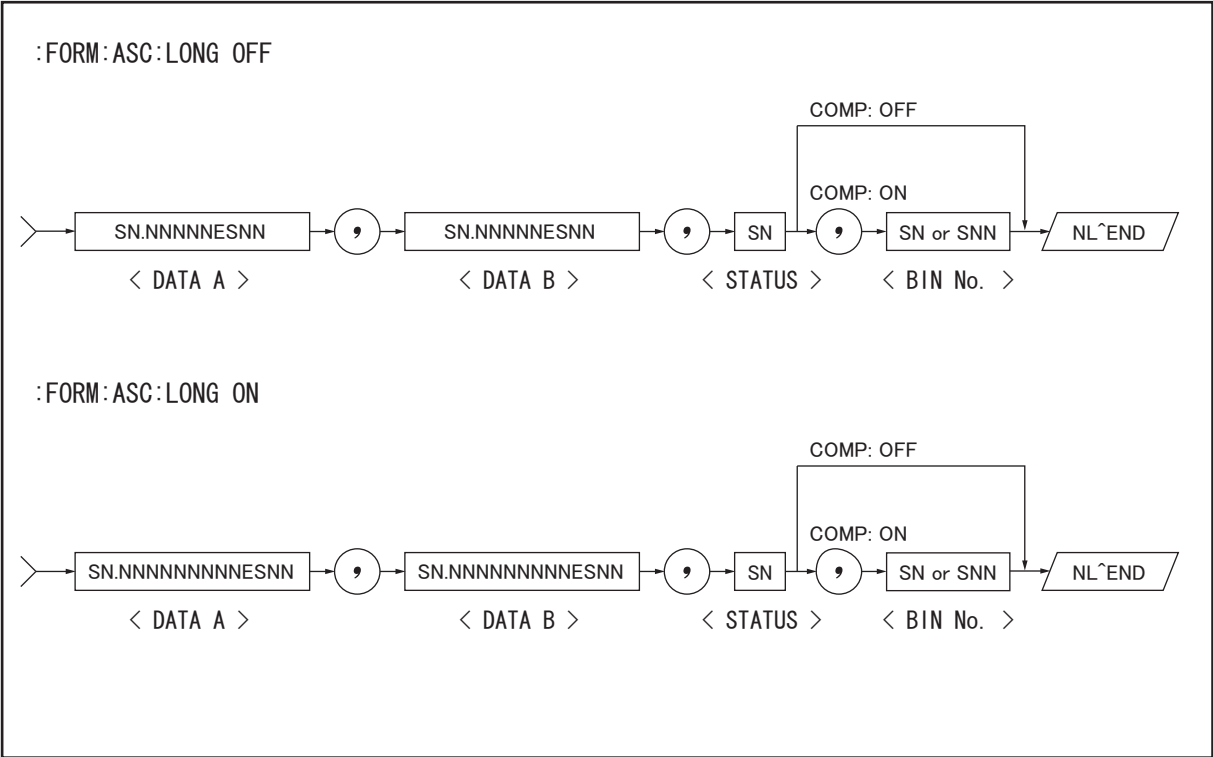

e4980aue1030

The <DATA A>, <DATA B>, <STATUS>, and <BIN No.> formats are as follows.

- <DATA A> and <DATA B> format:
The data output formats for <DATA A> (primary parameter's measurement data), and <DATA B> (secondary parameter's measurement data) uses the 12-ASCII character

8. Overview of Remote Control

Overview of Remote Control

Data Transfer

fixed-length format as follows.

SN.NNNNNNESNN (S:+/-, N: 0 to 9, E: Exponent Sign, LONG OFF)

SN.NNNNNNNNNNESNN (S:+/-, N: 0 to 9, E: Exponent Sign, LONG ON)

- <STATUS> Format:

The <STATUS> data shows the status of measurement data as follows.

-1:	No data (in the data buffer memory)
0:	Normal measurement data
+1:	Overload
+3:	Signal source overloaded
+4:	ALC (auto level control) unable to regulate

The data output formats for <STATUS> uses the two-ASCII character fixed-length format as follows.

SN (S:+/-, N: 0 to 4)

NOTE

When the <STATUS> is -1 or 1, the measurement data are given as 9.9E37. When the <STATUS> is 0, 3, or 4, however, the actual measurement data are output.

- <BIN No.> Format:

The <BIN No.> shows the bin sorting results as follows.

0:	OUT_OF_BINS
+1 to +9:	BIN 1 to BIN 9
+10:	AUX_BIN

The <BIN No.> data is output with the measurement data only when the comparator function is set to on.

The data output formats for <BIN No.> uses a two- or three-ASCII character data-length format as follows.

SN or SNN (S:+/-, N: 0 to 9)

The ASCII data output format on the LIST SWEEP page is shown below. The data loop is repeated according to the number of sweep points.

Figure 8-24 ASCII Format 2 (List Sweep)

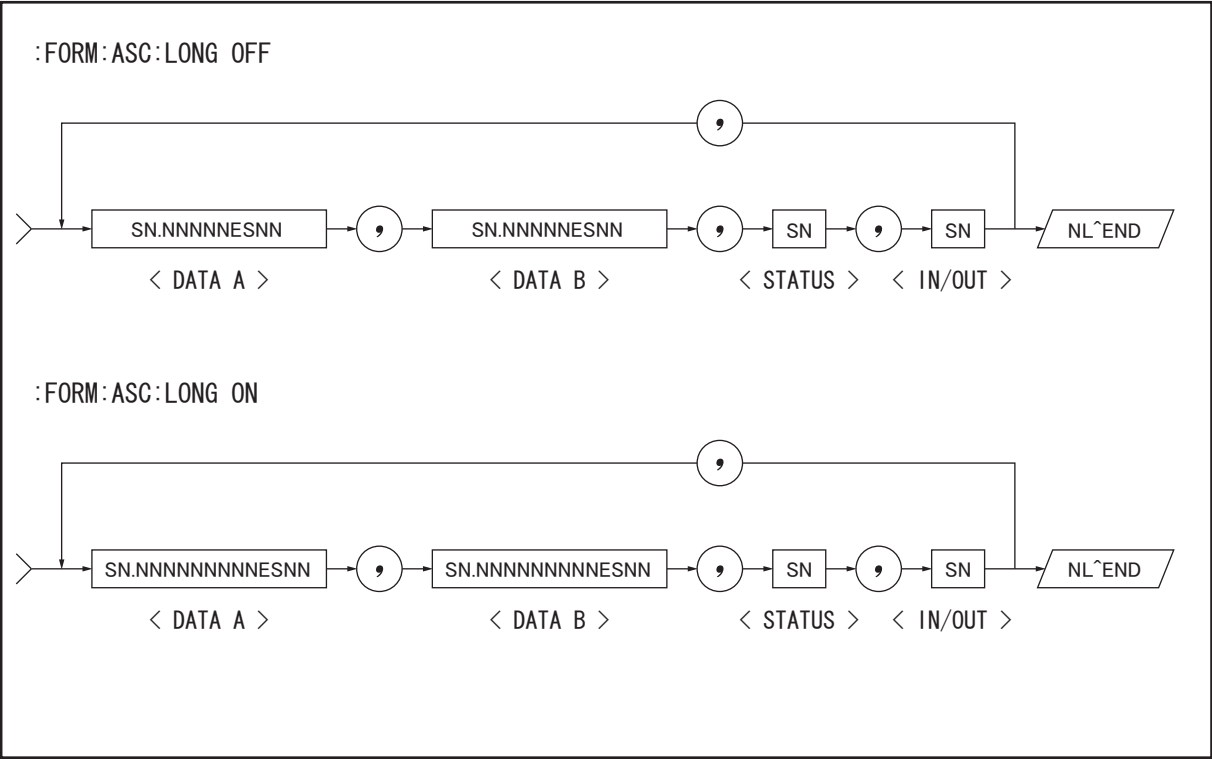

e4980aue1031

The `<DATA A>`, `<DATA B>`, and `<STATUS>` formats are the same as the formats on the MEAS DISPLAY, BIN No., or BIN COUNT page. Therefore, only the `<IN/OUT>` format will be described here.

- `<IN/OUT>` format:

The `<IN/OUT>` data shows the result of the list sweep's comparator function.

- 1: LOW
- 0: IN
- +1: HIGH

When the comparator function of the list sweep measurement is not used, the `<IN/OUT>` data output result is 0 (zero).

The data output formats for `<IN/OUT>` use the two-ASCII character fixed-length format as follows.

SN (S: +/-, N: 0 to 1)

Overview of Remote Control Data Transfer

BINARY Format

When the :FORM:DATA REAL,64 command is executed, the E4980A transfers data in the BINARY format. This BINARY format is the 64-bit floating point binary format specified in IEEE Standard 754-1985. The BINARY data output format on the MEAS DISPALY, BIN No, or BIN COUNT page is shown below.

Figure 8-25 BINARY Format 1

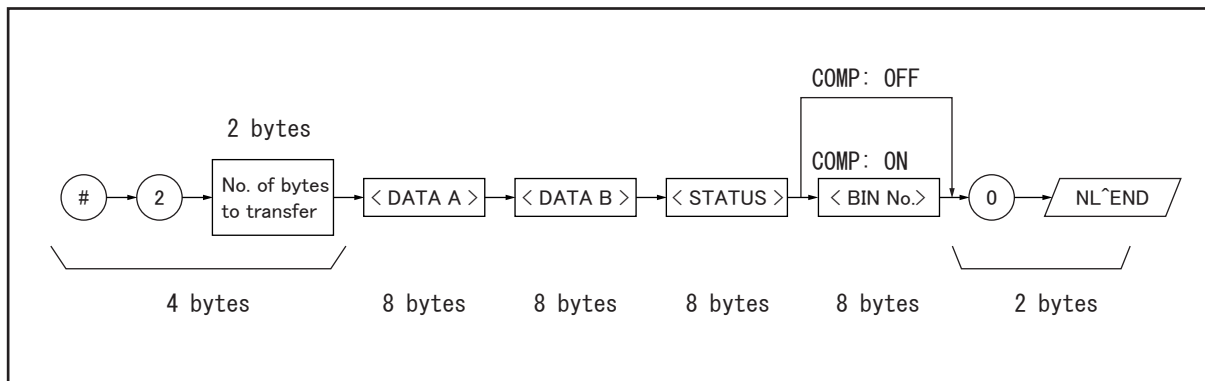

e4980aue1032

The BINARY data output format consists of the first four bytes (described below), <DATA A>, <DATA B>, <STATUS>, <BIN No.>, 0 (ASCII), and the terminator (NL).

- | | |
|-------------------------------------|----------------------------------------------------------------------------------|
| # (1 byte): | A code for the BINARY data output format (ASCII character) |
| 2 (1 byte): | The number of the bytes for the “No. of the bytes to transfer” (ASCII character) |
| No. of bytes to transfer (2 bytes): | The number of data bytes of <DATA A>, <DATA B>, <BIN No.> and 0 |

Data formats of the <DATA A>, <DATA B>, <STATUS>, and <BIN No.> are common (8 bytes, IEEE754 floating point format) as follows. The meaning of each data item is the same as that in the ASCII format.

Figure 8-26 8 bytes, IEEE754 floating point format

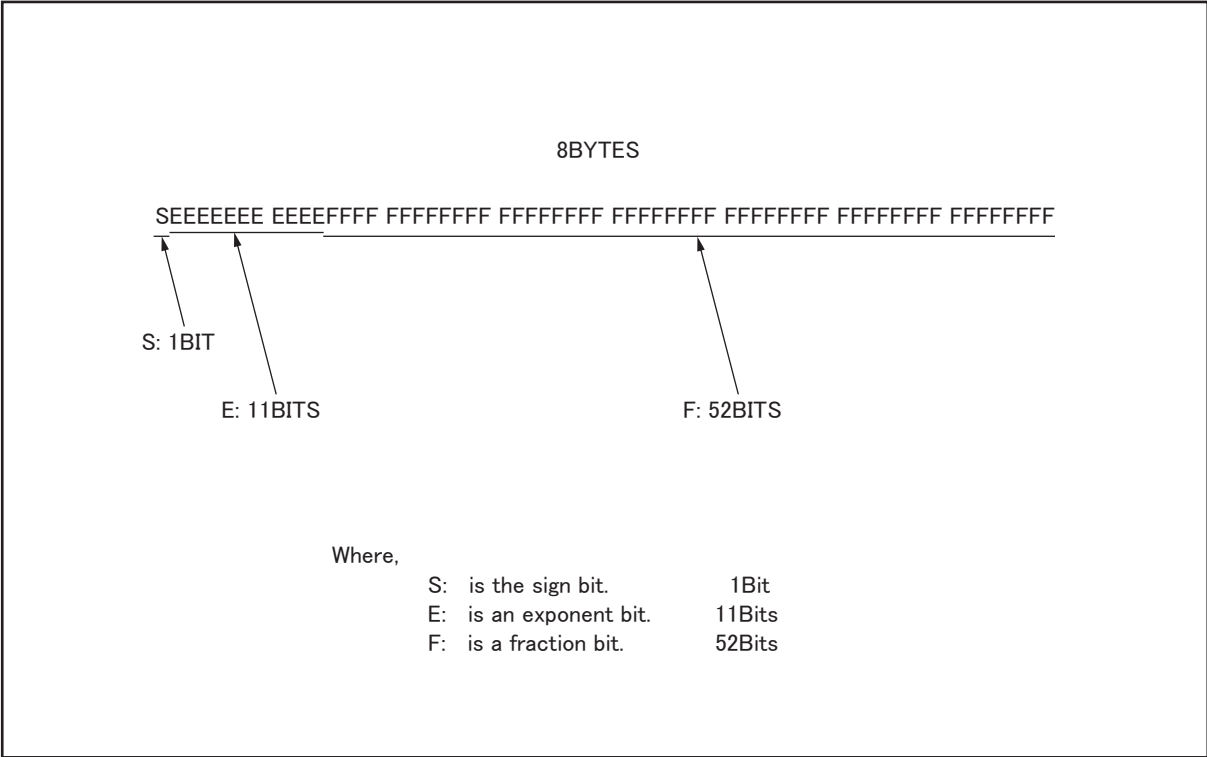

e4980aue1034

8. Overview of Remote Control

The real number RN represented in the floating point format is provided by employing the following formula. (EXP: Exponent part (E) converted to decimal, f: Fractional part (F) converted to decimal notation)

- When $0 < EXP < 1111111111$ (2047)
 $RN = (-1)S \times 2^{(EXP-1023)} \times \{1 + f / (252)\}$
- When $EXP = 0$
 $RN = (-1)S \times 2^{-1022} \times \{f / (252)\}$
- When $EXP = 0, f = 0$
 $RN = 0$

For example,
 $S = 1$
 $EXP = 0111111 1111$ (1023)
 $f = 1,000,000,000,000,000,000,000,000,000,000,000,000,000,000,000,000,000,000,000,000,000,000,000,000,000,000$ (251)

$$RN = (-1)1 \times 2^{(1023 - 1023)} \times \{1 + (251 / 252)\}$$

$$= -1 \times 1 \times 1.5$$

$$= -1.5$$

When the list sweep measurement is performed, the binary data format is as follows. <DATA A>, <DATA B>, <STATUS>, and <IN/OUT> are repeated as many times as there are sweep points. Each data format is the same as the 8-byte data format described

Overview of Remote Control
Data Transfer

previously.

Figure 8-27 Binary Format 2 (List sweep)

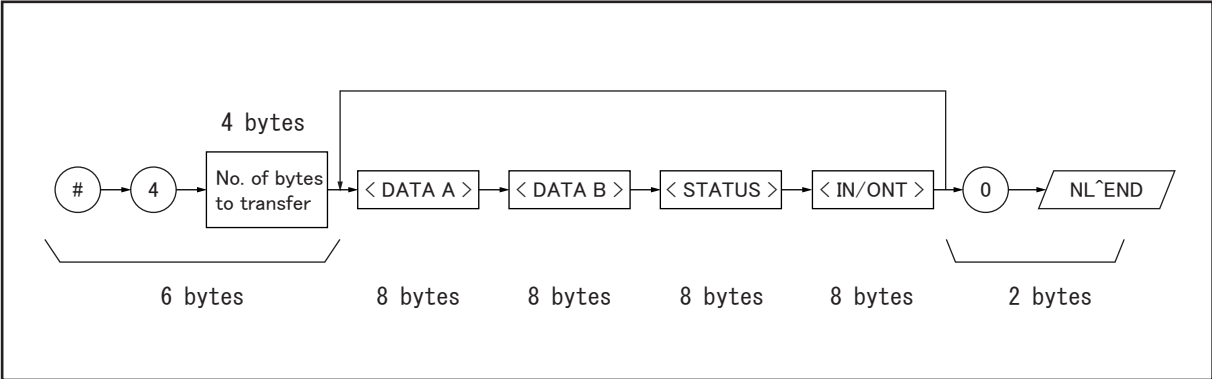

e4980aue1033

Status Byte

The status byte register contains an 8-bit word that the E4980A places on the GPIB bus when it is serially polled.

The value of each bit indicates the status of an internal function of the E4980A, and two bits of the status byte are used as summary bits of the registers. Bits are set to “1” and reset to “0.”

Figure 8-28 Status Byte Register

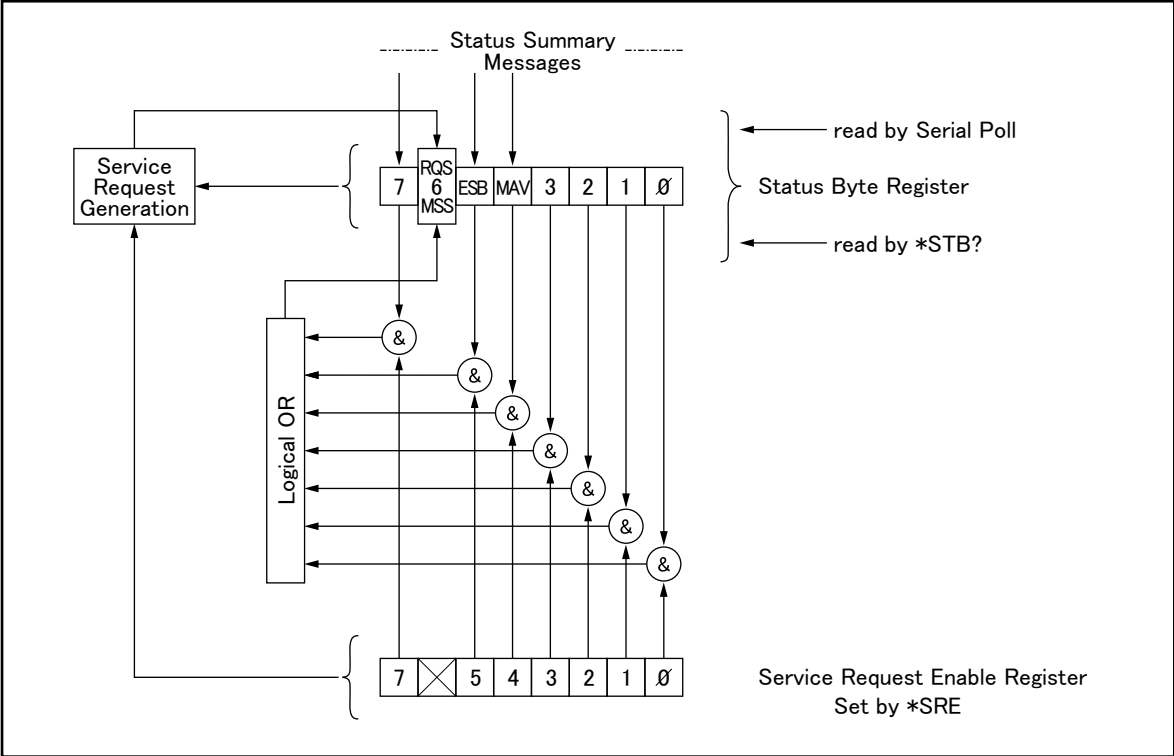

e4980aue1123

8. Overview of Remote Control

Overview of Remote Control
Status Byte

Table 8-1 gives the individual bit assignments of the status byte and its bit weights. When you read the status byte using GPIB serial polling, the value is the sum of the total bit weights of all the high bits existing at the time you read the byte. After serial polling of the status byte, only bit 6 (RQS) is cleared.

Table 8-1 Status Bit definition of the Status Byte Register

Bit No.	Bit Weight	Name	Description
0	1	unused	always 0 (zero)
1	2	unused	always 0 (zero)
2	4	unused	always 0 (zero)
3	8	unused	always 0 (zero)
4	16	MAV (message available)	This bit is set to "1" when the E4980A has available data to output that have not been read yet. This bit is reset to "0" when all the data have been retrieved. (This bit is not cleared by serial polling.)
5	32	Standard Event Status Register Summary	This bit is set to "1" when any enabled bits of the standard event status register have been set to "1." This bit is cleared when all bits of the standard event status register are set to "0." (This bit is not cleared by serial polling).
6	64	RQS	<p>Bit 6 serves two functions (RQS/MSS), depending on how it is read.</p> <p>RQS (Request Service) Bit If bit 6 is read in the serial polling process, it is treated as an RQS bit and is reset during the serial polling process.</p> <p>MSS (Master Summary) Bit If bit 6 is read using the *STB? (status byte) query, it is treated as an MSS bit, and its value is not changed by executing the *STB? query.</p> <p>To understand this operation, think of the RQS and MSS bits as two inputs to a multiplexer (MUX) and the output of the MUX being bit 6 of the status byte register.</p> <p>During the serial polling operation the MUX path selected is from the service request generation circuit to bit 6, so bit 6 represents the RQS bit.</p> <p>During execution of the *STB? query the MUX path selected is from the master summary bit generation circuit to bit 6, so bit 6 represents the MSS bit.</p> <p>To clear the MSS bit, all bits of the original registers corresponding to the enabled summary bit in the status byte and the output buffer of the E4980A must be cleared. When you read the status byte including the MSS bit instead of the RQS bit, the *STB? query must be used. The *STB? query clears neither the MSS bit nor the RQS bit.</p>
7	128	Operation Status Register Summary	This bit is set to "1" when one or more enabled bits of the operation status register is set to "1." This bit is cleared when all bits of the operation status register are set to 0. (This bit is not cleared by serial polling.)

Enabling the Status Byte

A service request (SRQ) will be generated when any enabled bit in the status byte register is set to “1.” Therefore, to enable/disable any bits of the status byte register, you can set bits in the service request enable register. These bits correspond to bits in the status byte register. When a bit is set in the service request enable register, it enables that bit in the status byte register to request service. To set bits in the service request enable register, the *SRE command is used. The syntax of the *SRE command is:

*SRE <n>
Where, <n>: decimal number (0 to 255)

For example,
If <n> is equal to 160 (10100000 in binary notation), bits 5 and 7 are enabled as follows.

Bit No. of Status Byte	MSB	LSB
	7	6 5 4 3 2 1 0
Bit Pattern for *SRE command	1 0 1 0 0 0 0 0	

In this case, when either bit 5 or bit 7 of the status byte is set to “1,” a service request is generated.

The default setting is *SRE 0 (all bits of the status byte are disabled).

NOTE

Bit 6 (RQS) is non-maskable, and bits 0 to 3 are always 0 (zero). Thus, it is meaningless to mask these bits. (The *SRE command’s bit pattern for masking bit 6 is ignored, while the *SRE command’s bit pattern for masking bits 0 to 6 is accepted, but is meaningless.)

Operation Status Register Structure

The operation status register group provides reports on operation status by summarizing multiple events into a summary message (bit 7) of the status byte. The structure of the operation status register group is shown in Figure 8-28 below. This group consists of the following three registers.

- Operation status condition register
- Operation status event register
- Operation status event enable register

Figure 8-29 **Operation Status Register Structure**

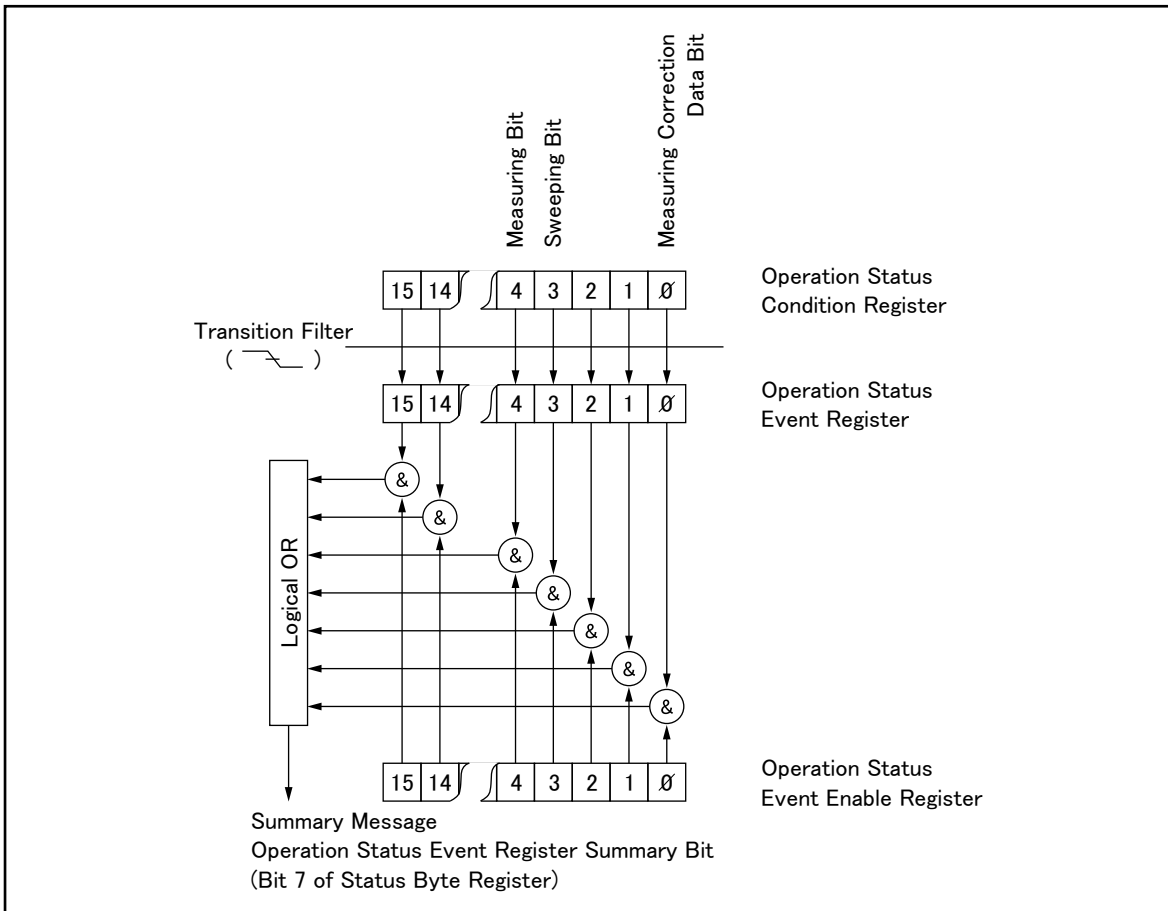

e4980aue1125

Operation Status Condition Register

The operation status condition register consists of 16 bits, and reflects these states in its condition bits. Therefore, each time the E4980A's condition is changed, its condition bit changes from "0" to "1," or from "1" to "0." Table 8-2 below shows each bit of the

operation status condition register.

Table 8-2 Operation Status Condition Register Assignments

Bit No.	Bit Weight	Name	Description
0	1	Correction Data Measurement Bit	0: Correction data measurement not in progress 1: Correction data measurement in progress
1	2	unused	always 0 (zero)
2	4	unused	always 0 (zero)
3	8	List Sweeping bit	0: List sweep measurement not in progress 1: List sweep measurement in progress
4	16	Measuring bit	0: Measurement not in progress 1: Measurement in progress
5 to 15		unused	always 0 (zero)

When you read the contents of the operation status condition register using the :STAT:OPER:COND? query, this register is not cleared. To clear it, change the device's operation state by setting all bits to 0.

Operation Status Event Register

The operation status event register consists of 16-bit registers, and each event bit in the event register corresponds to a condition bit in the operation status condition register. Each event bit is set to "1" when its corresponding bit in the condition register makes a "1"-to-"0" transition only. A negative transition filter is used.

Table 8-3 Operation Status Event Register Assignments

Bit No.	Bit Weight	Name	Description
0	1	Correction Data Measurement Complete Bit	This bit is set to "1" when the OPEN, SHORT, or LOAD correction data measurement is completed.
1	2	unused	always 0 (zero)
2	4	unused	always 0 (zero)
3	8	List Sweep Measurement Complete Bit	This bit is set to "1" when a last sweep point measurement of the list sweep measurement is completed.
4	16	Measurement Complete Bit	This bit is set to "1" when a single point measurement is completed. This bit indicates a corrected measured value.
5 to 15		unused	always 0 (zero)

When you read the contents of the operation status event register using the :STAT:OPER:EVEN? query, the operation status event register is cleared, and bit 7 of the status byte is reset to "0."

Enabling the Operation Status Event Register

An operation status register summary (bit 7 of the status byte) will be set when any enable bit in the operation status event register is set to "1." To enable/disable any bits of this register, the operation status event enable register is used. This particular register is the

Overview of Remote Control Status Byte

same length as the operation status event register. When a bit is set in the enable register, it enables the corresponding bit in the event register to request a service. To set any bit in the enable register, the `:STAT:OPER:ENAB` command is used. The syntax of the `:STAT:OPER:ENAB` command is:

`:STAT:OPER:ENAB <n>`

where, `<n>`: decimal number (-32768 to 32767)

For example,

If `<n>` is equal to 8 (0000000000001000 in binary), bit 3 is enabled as follows.

Bit No. of Event Register	MSB	LSB
	15	14 13 12 11 10 9 8 7 6 5 4 3 2 1 0
Event Enable Register	0	0 0 0 0 0 0 0 0 0 0 0 1 0 0 0

In this case, when bit 3 of the operation status event register is set to “1,” the operation status register summary (bit 7 of the status byte) is set to “1.”

The default setting is `:STAT:OPER:ENAB 0` (all bits of the operation status event register are disabled).

NOTE

Bit 1, bit 2, and bits 5 to 15 are always 0 (zero). Thus, it is meaningless to mask them.

Standard Event Status Register

The standard event status register consists of 8 bits as shown in Table 8-4 and is defined in IEEE 488.2-1987. If one or more enable bits of the standard event status register is set to “1,” bit 5 (standard event status register summary) of the status byte is set to “1.”

When each error bit (bits 2, 3, 4, and 5) of the standard event status register is set to “1,” an error message with the following error numbers is input to the error queue.

Bit No.	Error No.
2 (query error)	-400 to -499
3 (Device specific error)	0 to 32,767, -300 to -399
4 (Execution error)	-200 to -299
5 (Command error)	-100 to -199

When you read the contents of the standard event status register using the *ESR? query command, the standard event status register is cleared, and bit 5 of the status byte is reset to “0.”

Figure 8-30 Standard Event Status Register

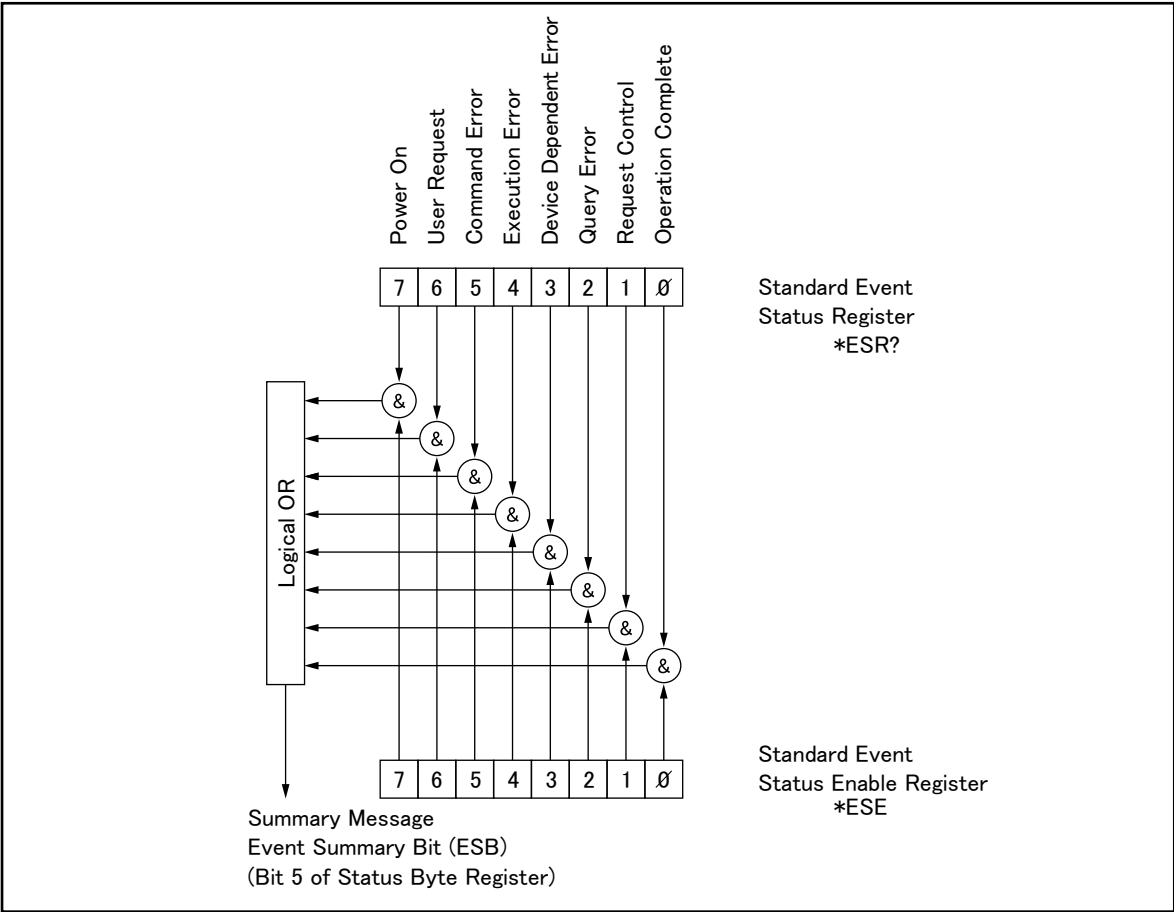

e4980aue1124

8. Overview of Remote Control

Table 8-4 Standard Event Status Register Assignments

Bit No.	Bit Weight	Name	Description
0	1	Operation Complete (OPC) Bit	This bit is set to “1” when the E4980A has completed all selected pending operations before sending the *OPC command.
1	2	Request Control (RQC) Bit	always 0 (zero)
2	4	Query Error (QYE) Bit	This bit is set to “1” when reading data from the output buffer and no data was present, or when the data was lost.
3	8	Device specific error (DDE) Bit	This bit is set to “1” when a device-dependent error (except for the command error, query error, and execution error) has occurred.
4	16	Execution Error (EXE) Bit	This bit is set to “1” when a parameter following a header of the GPIB command was evaluated by the E4980A as being outside its legal input range or is otherwise inconsistent with the E4980A’s capabilities.
5	32	Command Error (CME) Bit	This bit is set to “1” if the following command errors occur. <ul style="list-style-type: none"> • IEEE 488.2 syntax error • The device received a TRIGGER (GET) bus command inside a program message.
6	64	User Request (URQ) Bit	always 0 (zero)
7	128	Power On (PON) Bit	This bit is set to “1” when the E4980A’s power supply has been turned off and then on since the last time this register was read.

Enabling the Event Status Register

An event status register summary (bit 5 of the status byte) is set to “1” when any enabled bit in the standard event status register is set to “1.” To enable/disable any bits of the standard event status register, you can set the bits in the standard event status enable register. These bits correspond to bits in the standard event status register. When a bit is set in the standard event status enable register, it enables the corresponding bit in the standard event status register to set bit 5 of the status byte (event status register summary bit) to “1.” To set any bit in the standard event status enable register, the *ESE command is used. The syntax of the *ESE command is:

*ESE <n>

Where, <n>: decimal number (0 to 255).

For example,

If <n> is equal to 34 (00100010), bit 1 and bit 5 are enabled as follows.

Bit No. of Event Status Register	MSB	LSB
	7	6 5 4 3 2 1 0
Bit Pattern for *ESE command	0 0 1 0 0 0 1 0	

When either bit 1 or 5 of the status byte is set to “1,” a service request will be generated. The default setting is *ESE 0 (all bits of the standard event status register are disabled).

NOTE

Bits 1 and 6 of the event status register are always 0 (zero). Thus it is meaningless to mask these bits.

Overview of Remote Control
Status Byte

9

SCPI Command Reference

This chapter describes the SCPI command reference for the Agilent E4980A. It describes the commands using their abbreviated format in alphabetical order. If you want to look up commands using their fully qualified format, refer to the index for the desired SCPI command. If you want to look up commands by their function, refer to SCPI command list by function.

Notational conventions in this command reference

This section describes the rules to read the description of the commands in this chapter.

Syntax

A part with the heading “Syntax” describes the syntax to send a command from the external controller to the E4980A. A syntax consists of a command part and a parameter part. A space is used to separate the command part and the parameter part.

If there are several parameters, a comma is used instead as the separator between adjacent parameters. Three periods (...) between commas indicate that parameters in that part are omitted. For example, <numeric 1>, ..., <numeric 4> indicates that four parameters, <numeric 1>, <numeric 2>, <numeric 3>, and <numeric 4>, are required.

String-type parameters, <string>, <string 1>, and so on, must be enclosed in double quotation marks (“”). Furthermore, <block> indicates block-format data.

You can omit the lowercase letters in syntax. For example, “:BIAS:POLarity:CURRent” can be shortened to “:BIAS:POL:CURR.”

The definitions of symbols used in the syntax are as follows.

<>	Characters enclosed in this pair of symbols are necessary parameters when sending a command.
[]	A part enclosed in these parentheses can be omitted.
{ }	A part enclosed in these parentheses indicates that you must select one of the items in this part. Individual items are separated by a vertical bar ().

For example, “:BIAS:CURR 0.001,” “:BIAS:CURRENT:LEVEL 1E-3,” and so on are valid for the syntax given below.

Syntax

:BIAS:CURRent[:LEVel] <numeric>

Description

A part with the heading “Description” describes how to use the command or the operation when executed.

Parameters

A part with heading “Parameters” describes parameters necessary for sending the command. When a parameter is a value type or a string type enclosed with $\langle \rangle$, its description, allowable setup range, preset (factory-set) value, and so on are given; when a parameter is a selection type enclosed by { }, the description of each selection item is given.

Equivalent key

A part with the heading “Equivalent key” shows the operational procedure for the front panel keys. An equivalent key has the same effect as a certain command.

- | | |
|---------------------|------------------------------------------------------------------------------------------------------------------------------------------------------------------------------------------------------------|
| [Key] | Indicates that you press the key named Key . |
| [Key] - Item | Indicates a series of key operations in which you press [Key] , select the item called Item (softkey or field name) on the displayed menu using the cursor keys, and then press the softkey. |

E4980A commands

This section describes the commands specific to the E4980A.

*CLS

Syntax	*CLS
Description	Clears the following: <ul style="list-style-type: none">• Error Queue• Status Byte Register• Standard Event Status Register• Operation Status Event Register• Questionable Status Event Register (No Query)
Equivalent key	No equivalent key is available on the front panel.

*ESE

Syntax	*ESE <numeric> *ESE?
Description	Sets the value of the Standard Event Status Enable Register. Refer to the chapter on Remote Control.
Parameter	

	<Numeric>
Range	0 to 255

Equivalent key No equivalent key is available on the front panel.

*ESR?

Syntax	*ESR?
Description	Reads out the value of the Standard Event Status Register. Executing this command clears the register value. Refer to the chapter on Remote Control. (Query Only)
Equivalent key	No equivalent key is available on the front panel.

*IDN?

Syntax	*IDN?
--------	-------

Description Reads out the product information (manufacturer, model number, serial number, and firmware version number) of the E4980A. (Query Only)

Equivalent key [System] - SYSTEM INFO

***LRN?**

Syntax *LRN?

Description Returns all the necessary commands to set the E4980A at its present state. The response can later be sent back to the E4980A to place it in this state. (Query Only)

Equivalent key No equivalent key is available on the front panel.

***OPC**

Syntax *OPC

Description When all the pending operations have ended, sets OPC bit (Bit 0) of the Standard Event Status Register. (No Query)

Equivalent key No equivalent key is available on the front panel.

***OPC?**

Syntax *OPC?

Description 1 is read out at the completion of all pending operations. (Query Only)

Equivalent key No equivalent key is available on the front panel.

***OPT?**

Syntax *OPT?

Description Returns the installed option numbers on the E4980A. (Query Only)

Equivalent key [System] - SYSTEM INFO

***RST**

Syntax *RST

Description Resets the instrument settings. The preset state is different from that when resetting is performed using the :SYSTem:PRESet. (No Query)

Equivalent key [Preset] - CLEAR SETTING - OK

***SRE**

Syntax *SRE <numeric>

*SRE?

Description Sets the value of the Service Request Enable register. Refer to the chapter on Remote Control.

Parameter

	<Numeric>
Range	0 to 255

Equivalent key No equivalent key is available on the front panel.

***STB?**

Syntax *STB?

Description Returns the value of the Status Byte Register. Refer to the chapter on Remote Control. (Query Only)

Equivalent key No equivalent key is available on the front panel.

***TRG**

Syntax *TRG

Description BUS triggers the unit and returns the result.

Equivalent key No equivalent key is available on the front panel.

NOTE

*TRG is not a query command, but returns the value. An error will occur when sending the next command unless the value is read.

***TST?**

Syntax *TST?

Description Does nothing. The self-test is not executed by this command in the case of the E4980A. Always returns 0. (Query Only)

Equivalent key No equivalent key is available on the front panel.

***WAI**

Syntax *WAI

Description Waits until all commands sent before this command have been executed. The following commands are then executed. (No Query)

Equivalent key No equivalent key is available on the front panel.

:ABORt

Syntax :ABORt

Description Resets the trigger system. The trigger state is then in the “Idle” state on the state diagram. (No Query)

Equivalent key [Meas Setup] - MEAS SETUP - REF A - MEAS ABORT
 [Meas Setup] - MEAS SETUP - B - MEAS ABORT
 [Meas Setup] - CORRECTION - OPEN - MEAS OPEN - ABORT
 [Meas Setup] - CORRECTION - SHORT - MEAS SHORT - ABORT

:AMPLitude:ALC

Syntax :AMPLitude:ALC {ON|OFF|1|0}
 :AMPLitude:ALC?

Description Enables the Automatic Level Control (ALC).

Parameter

	Description
ON or 1	Enables the Automatic Level Control
OFF or 0 (Preset value)	Disables the Automatic Level Control

Equivalent key [Meas Setup] - MEAS SETUP - ALC

:APERture

Syntax :APERture {SHORT|MEDIUM|LONG},<numeric>
 :APERture?

Description Sets the measurement time mode and the averaging rate.

Parameter

	Description
SHORT	Sets measurement time to Short
MEDIUM (Preset value)	Sets measurement time to Medium

	Description
LONG	Sets measurement time to Long

	<Numeric>
Range	1 to 256
Preset value	1
Resolution	1

Equivalent key [Meas Setup] - MEAS SETUP - MEAS TIME - SHORT
 [Meas Setup] - MEAS SETUP - MEAS TIME - MED
 [Meas Setup] - MEAS SETUP - MEAS TIME - LONG
 [Meas Setup] - MEAS SETUP - AVE

:BIAS:CURRent[:LEVel]

Syntax :BIAS:CURRent[:LEVel] <numeric>
 :BIAS:CURRent[:LEVel]?

Description Sets the DC bias current. Setting does not implicitly turn the DC bias ON. This command is effective when option 001 is installed. If the bias is set by :BIAS:VOLTage[:LEVel], the query command returns error No. 230. The parameter resolution depends on the current setting value.

Parameter

	<Numeric>
Range	-100 m to 100 m *1
Unit	A

*1. Depending on signal level.

Equivalent key [Display Format] - MEAS DISPLAY - BIAS
 [Meas Setup] > - MEAS SETUP - BIAS

:BIAS:POLarity:AUTO

Syntax :BIAS:POLarity:AUTO {ON|OFF|1|0}
 :BIAS:POLarity:AUTO?

Description Enables the Automatic Polarity Control. This command is effective when option 001 is installed.

Parameter

	Description
ON or 1	Enables the Automatic Polarity Control
OFF or 0 (Preset value)	Disables the Automatic Polarity Control

Equivalent key [Meas Setup] - MEAS SETUP - BIAS POL - AUTO
[Meas Setup] - MEAS SETUP - BIAS POL - FIX

:BIAS:POLarity:CURRent[:LEVel]?

Syntax :BIAS:POLarity:CURRent[:LEVel]?

Description Returns the actual output level of the applied bias current. If the automatic polarity control is turned ON, the inverse of the setting value may be returned when the polarity is inverted. If the automatic polarity control is turned OFF, the returned value is always the same as the one for :BIAS:CURRent[:LEVel]. (Query Only)

Equivalent key No equivalent key is available on the front panel.

:BIAS:POLarity:VOLTage[:LEVel]?

Syntax :BIAS:POLarity:VOLTage[:LEVel]?

Description Returns the actual output level of the applied bias current's voltage. If the automatic polarity control is turned ON, the inverse of the setting value may be returned when the polarity is inverted. If the automatic polarity control is turned OFF, the returned value is always the same as one for :BIAS:VOLTage[:LEVel]. (Query Only)

Equivalent key No equivalent key is available on the front panel.

:BIAS:RANGe:AUTO

Syntax :BIAS:RANGe:AUTO {ON|OFF|1|0}
:BIAS:RANGe:AUTO?

Description Sets the DC bias range to AUTO (ON) or FIX (OFF).
When the DC bias range is FIX, "#" is displayed in the BIAS field of the display.
When the DC bias range is set to FIX, resolution of the test signal voltage is fixed, and accuracy is changed. For details, refer to "DC bias signal" on page 419.

Parameter

	Description
ON or 1 (Preset value)	Sets the DC bias range to ON

	Description
OFF or 0	Sets the DC bias range to OFF

Equivalent key No equivalent key is available on the front panel.

:BIAS:STATe

Syntax :BIAS:STATe {ON|OFF|1|0}
:BIAS:STATe?

Description Enables DC bias. DC bias is automatically turned off after recalling the state from memory. When DC bias is set to ON, DC bias that has been set with :BIAS:CURRENT[:LEVel] or :BIAS:VOLTage[:LEVel] is output.

Parameter

	Description
ON or 1	Enables the DC bias
OFF or 0 (Preset value)	Disables the DC bias

Equivalent key [DC Bias]

:BIAS:VOLTage[:LEVel]

Syntax :BIAS:VOLTage[:LEVel] <numeric>
:BIAS:VOLTage[:LEVel]?

Description Sets the DC bias voltage. Setting does not implicitly turn the DC bias ON. If the bias is set by :BIAS:CURRENT[:LEVel], the query command returns error No. 230. The parameter resolution depends on the setting voltage value.

Parameter

	<Numeric>
Range	0,1.5,2 (without option 001) -40 to 40 ^{*1} (with option 001)
Preset value	0
Unit	V

*1. Depending on signal level.

Equivalent key [Display Format] - MEAS DISPLAY - BIAS
[Meas Setup] - MEAS SETUP - BIAS

:COMParator:ABIN

Syntax :COMParator:ABIN {ON|OFF|1|0}
:COMParator:ABIN?

Description Enables the auxiliary BIN counting function of the comparator.

Parameter

	Description
ON or 1	Enables the auxiliary BIN counting function
OFF or 0(Preset value)	Disables the auxiliary BIN counting function

Equivalent key [Meas Setup] - LIMIT TABLE - AUX - ON
[Meas Setup] - LIMIT TABLE - AUX - OFF

:COMParator:BEEPer

Syntax :COMParator:BEEPer {FAIL|PASS}
:COMParator:BEEPer?

Description Selects the condition for generating a beep sound: when sorting with the comparator fails (sorts into OUT OF BIN) or passes (sorts into BINs 1 to 9 or AUX BIN). The beep should be turned on by the :SYSTEM:BEEPer:STATE.

Parameter

	Description
FAIL (Preset value)	Sounds a beep when the test is failed
PASS	Sounds a beep when the test is passed

Equivalent key [Meas Setup] - LIMIT TABLE - BEEP - FAIL
[Meas Setup] - LIMIT TABLE - BEEP - PASS

:COMParator:BIN:CLEar

Syntax :COMParator:BIN:CLEar

Description Clears all of the BIN limit value settings. (No Query)

Equivalent key [Meas Setup] - LIMIT TABLE - BIN - CLEAR TABLE

:COMParator:BIN:COUNT:CLEAr

Syntax :COMParator:BIN:COUNT:CLEAr

Description Clears all BIN counts. (No Query)

Equivalent key [Display Format] - BIN COUNT - COUNT - RESET COUNT

:COMParator:BIN:COUNT:DATA?

Syntax :COMParator:BIN:COUNT:DATA?

Description Returns the comparator BIN count results (Query Only)

Query Response <Bin 1>,<Bin 2>,<Bin 3>,<Bin 4>,<Bin 5>,<Bin 6>,<Bin 7>,<Bin 8>,<Bin 9>,<Out of Bin>,<Aux Bin><NL^END>

Equivalent key No equivalent key is available on the front panel.

:COMParator:BIN:COUNT[:STATe]

Syntax :COMParator:BIN:COUNT[:STATe] {ON|OFF|1|0}
:COMParator:BIN:COUNT[:STATe]?

Description Enables the BIN count function.

Parameter

	Description
ON or 1	Enables the BIN count function
OFF or 0 (Preset value)	Disables the BIN count function

Equivalent key [Display Format] - BIN COUNT - COUNT - COUNT ON
[Display Format] - BIN COUNT - COUNT - COUNT OFF

:COMParator:MODE

Syntax :COMParator:MODE {ATOLerance|PTOLerance|SEQUence}
:COMParator:MODE?

Description Selects the limit mode of the comparator function. This command clears the primary and secondary parameter limit values.

Parameter

	Description
ATOLerance	Sets the Comparator mode. This command clears the limit table data and secondary limits at "ABS."
PTOLerance (Preset value)	Sets the Comparator mode. This command clears the limit table data and secondary limits at "%."
SEQuence	Sets the Comparator mode. This command clears the limit table data and secondary limits at "SEQ."

Equivalent key

[Meas Setup] - LIMIT TABLE - MODE - ABS
 [Meas Setup] - LIMIT TABLE - MODE - %
 [Meas Setup] - LIMIT TABLE - MODE - SEQ

:COMParator:SEQuence:BIN

Syntax

:COMParator:SEQuence:BIN <Bin 1 Low>,<Bin 1 High>,... ,<Bin n High>
 :COMParator:SEQuence:BIN?

Description

Sets the low/high limit values of the BINs for the sequential mode of the comparator function. These limits can be set only when the limit mode is set in the sequential mode. Of course, the lower limit value must be lower than that of the upper limit. If a BIN is not used, this command returns the values of -9.9E37 and 9.9E37 for the lower and upper limits, respectively.

Parameter

	<Bin 1 Low>
Unit	Depends on :FUNction:IMPedance[:TYPE]

	<Bin n High>
Range of n	1 to 9
Unit	Depends on :FUNction:IMPedance[:TYPE]

Example of Use

```
viVPrintf(Agte4980a, "COMP:MODE SEQ" + vbLf, 0)
viVPrintf(Agte4980a, "FUNC:IMP RX" + vbLf, 0)
viVPrintf(Agte4980a, "COMP:SEQ:BIN -9.9e37, 100,110,120,130,140,
9.9e37,150" + vbLf, 0)
```

Equivalent key

[Meas Setup] - LIMIT TABLE - Bin 1 LOW
 [Meas Setup] - LIMIT TABLE - Bin 1 - 9 HIGH

:COMParator:SLIMit

Syntax :COMParator:SLIMit <Low>,<High>

:COMParator:SLIMit?

Description Sets the lower/upper limit values for the comparator function's secondary parameter.

Parameter

	<Low>,<High>
Preset value	-9.9E+37, 9.9E+37
Unit	Depends on :FUNCTION:IMPedance[:TYPE]

Equivalent key [Meas Setup] - LIMIT TABLE - 2nd LOW

[Meas Setup] - LIMIT TABLE - 2nd HIGH

:COMParator[:STATe]

Syntax :COMParator[:STATe] {ON|OFF|1|0}

:COMParator[:STATe]?

Description Enables the comparator function.

Parameter

	Description
ON or 1	Enables the comparator function
OFF or 0 (Preset value)	Disables the comparator function

Equivalent key [Meas Setup] - LIMIT TABLE - COMP - ON

[Meas Setup] - LIMIT TABLE - COMP - OFF

:COMParator:SWAP

Syntax :COMParator:SWAP {ON|OFF|1|0}

:COMParator:SWAP?

Description Enables the swap parameter function.

Parameter

	Description
ON or 1	9 BIN settings are used for the secondary parameter

	Description
OFF or 0 (Preset value)	9 BIN settings are used for the primary parameter

Equivalent key [Meas Setup] - LIMIT TABLE - FUNC - SWAP PARAM

:COMParator:TOLerance:BIN[1-9]

Syntax :COMParator:TOLerance:BIN[1-9] <low>,<high>
:COMParator:TOLerance:BIN[1-9]?

Description Sets the lower/upper limit values of each BIN for the comparator function's tolerance mode. These limits can be set only when the limit mode is set to the tolerance mode. When the lower limit or upper limit is not set, it returns -9.9E37 and 9.9E37, respectively.

Parameter

	<low>,<high>
Unit	Depends on :FUNcTion:IMPedance[:TYPE]

Equivalent key [Meas Setup] - LIMIT TABLE - LOW
[Meas Setup] - LIMIT TABLE - HIGH

:COMParator:TOLerance:NOMinal

Syntax :COMParator:TOLerance:NOMinal <numeric>
:COMParator:TOLerance:NOMinal?

Description Sets the nominal value for the comparator function's tolerance mode. This can be set only when the limit mode is set to the tolerance mode.

Parameter

	<Numeric>
Preset value	0

Equivalent key [Meas Setup] - LIMIT TABLE - NOM

:CONTRol:CBias:STATe

Syntax :CONTRol:CBias:STATe {ON|OFF|1|0}
:CONTRol:CBias:STATe?

Description Enables the current bias I/F. If the 42841A is connected, the preset status is ON.

Parameter

	Description
ON or 1	Enables the current bias I/F
OFF or 0 (Preset value)	Disables the current bias I/F

Equivalent key

[System] - SYSTEM INFO - CURR BIAS I/F - ON
[System] - SYSTEM INFO - CURR BIAS I/F - OFF

:CONTrol:HANDler:STATe

Syntax

:CONTrol:HANDler:STATe {ON|OFF|1|0}
:CONTrol:HANDler:STATe?

Description

Enables the handler I/F.

Parameter

	Description
ON or 1	Enables the handler I/F
OFF or 0 (Preset value)	Disables the handler I/F

Equivalent key

[System] - SYSTEM INFO - HANDLER I/F - ON
[System] - SYSTEM INFO - HANDLER I/F - OFF

:CONTrol:SCANner:STATe

Syntax

:CONTrol:SCANner:STATe {ON|OFF|1|0}
:CONTrol:SCANner:STATe?

Description

Enables the scanner I/F.

Parameter

	Description
ON or 1	Enables the scanner I/F
OFF or 0(Preset value)	Disables the scanner I/F

Equivalent key

[System] - SYSTEM INFO - SCANNER I/F - ON
[System] - SYSTEM INFO - SCANNER I/F - OFF

:CORRection:LENGth

Syntax :CORRection:LENGth <numeric>
:CORRection:LENGth?

Description Selects the cable length correction setting.

Parameter

	<Numeric>
Range	0 1 2 4
Preset value	0
Unit	m

Equivalent key [Meas Setup] - CORRECTION - CABLE - 0 m
[Meas Setup] - CORRECTION - CABLE - 1 m
[Meas Setup] - CORRECTION - CABLE - 2 m
[Meas Setup] - CORRECTION - CABLE - 4 m

:CORRection:LOAD:STATe

Syntax :CORRection:LOAD:STATe {ON|OFF|1|0}
:CORRection:LOAD:STATe?

Description Enables LOAD correction.

Parameter

	Description
ON or 1	Enables LOAD correction
OFF or 0 (Preset value)	Disables LOAD correction

Equivalent key [Meas Setup] - CORRECTION - LOAD - ON
[Meas Setup] - CORRECTION - LOAD - OFF

:CORRection:LOAD:TYPE

Syntax :CORRection:LOAD:TYPE
{CPD|CPQ|CPG|CPRP|CSD|CSQ|CSRS|LPD|LPQ|LPG|LPRP|LSD|LSQ|LSRS|RX|ZTD|ZTR|GB|YTD|YTR}
:CORRection:LOAD:TYPE?

Description Selects the measurement function of the reference values for load correction.

Parameter

	Description
CPD(Preset value)	Sets the type of LOAD correction reference to “Cp-D”
CPQ	Sets the type of LOAD correction reference to “Cp-Q”
CPG	Sets the type of LOAD correction reference to “Cp-G”
CPRP	Sets the type of LOAD correction reference to “Cp-Rp”
CSD	Sets the type of LOAD correction reference to “Cs-D”
CSQ	Sets the type of LOAD correction reference to “Cs-Q”
CSRS	Sets the type of LOAD correction reference to “Cs-Rs”
LPD	Sets the type of LOAD correction reference to “Lp-D”
LPQ	Sets the type of LOAD correction reference to “Lp-Q”
LPG	Sets the type of LOAD correction reference to “Lp-G”
LPRP	Sets the type of LOAD correction reference to “Lp-Rp”
LSD	Sets the type of LOAD correction reference to “Ls-D”
LSQ	Sets the type of LOAD correction reference to “Ls-Q”
LSRS	Sets the type of LOAD correction reference to “Ls-Rs”
RX	Sets the type of LOAD correction reference to “R-X”
ZTD	Sets the type of LOAD correction reference to “Z-thd”
ZTR	Sets the type of LOAD correction reference to “Z-thr”
GB	Sets the type of LOAD correction reference to “G-B”
YTD	Sets the type of LOAD correction reference to “Y-thd”
YTR	Sets the type of LOAD correction reference to “Y-thr”

Equivalent key The softkeys of [Meas Setup] - CORRECTION - FUNC field

:CORRection:MEtHod

Syntax :CORRection:MEtHod {SINGle|MULTiple}
:CORRection:MEtHod?

Description Selects the correction mode (Single or Multi). Scanner I/F should be installed for the Multi mode.

Parameter

	Description
SINGLE (Preset value)	Sets the correction mode to “SINGLE”
MULTiple	Sets the correction mode to “MULTI”

Equivalent key [Meas Setup] - CORRECTION - MODE - SINGLE
[Meas Setup] - CORRECTION - MODE - MULTI

:CORRection:OPEN[:EXECute]

Syntax :CORRection:OPEN[:EXECute]

Description Executes OPEN correction based on all frequency points. (No Query)

Equivalent key [Meas Setup] - CORRECTION - OPEN - MEAS OPEN

:CORRection:OPEN:STATe

Syntax :CORRection:OPEN:STATe {ON|OFF|1|0}
:CORRection:OPEN:STATe?

Description Enables OPEN correction.

Parameter

	Description
ON or 1	Enables OPEN correction.
OFF or 0 (Preset value)	Disables OPEN correction.

Equivalent key [Meas Setup] - CORRECTION - OPEN - ON
[Meas Setup] - CORRECTION - OPEN - OFF

:CORRection:SHORT[:EXECute]

Syntax :CORRection:SHORT[:EXECute]

Description Executes SHORT correction based on all frequency points. (No Query)

Equivalent key [Meas Setup] - CORRECTION - SHORT - MEAS SHORT

:CORRection:SHORT:STATe

Syntax :CORRection:SHORT:STATe {ON|OFF|1|0}

:CORRection:SHORt:STATe?

Description Enables SHORT correction.

Parameter

	Description
ON or 1	Enables SHORT correction
OFF or 0 (Preset value)	Disables SHORT correction

Equivalent key [Meas Setup] - CORRECTION - SHORT - ON

[Meas Setup] - CORRECTION - SHORT - OFF

:CORRection:SPOT[1-201]:FREQuency

Syntax :CORRection:SPOT[1-201]:FREQuency <numeric>

:CORRection:SPOT[1-201]:FREQuency?

Description Sets the frequency for the specified measurement point. The mode selected by :CORRection:METHod is chosen as the correction mode for the specified point.

Parameter

	<Numeric>
Range	20 to 2M
Preset value	20
Unit	Hz

Equivalent key [Meas Setup] - CORRECTION - FREQ

:CORRection:SPOT[1-201]:LOAD[:EXECute]

Syntax :CORRection:SPOT[1-201]:LOAD[:EXECute]

Description Executes LOAD correction at the specified measurement point. (No Query)

Equivalent key [Meas Setup] - CORRECTION - FREQ - MEAS LOAD

:CORRection:SPOT[1-201]:LOAD:STANdard

Syntax :CORRection:SPOT[1-201]:LOAD:STANdard <reference value for primary>,<reference value for secondary>

:CORRection:SPOT[1-201]:LOAD:STANdard?

Description Sets the standard reference values at the specified measurement point. The measurement

function for the reference values can be selected using :CORRection:LOAD:TYPE.

Parameter

	<reference value for primary>,<reference value for secondary>
Preset value	0
Unit	Depends on :CORRection:LOAD:TYPE

Equivalent key

[Meas Setup] - CORRECTION - MODE - MULTI
[Meas Setup] - CORRECTION - REF A
[Meas Setup] - CORRECTION - REF B

:CORRection:SPOT[1-201]:OPEN[:EXECute]

Syntax

:CORRection:SPOT[1-201]:OPEN[:EXECute]

Description

Executes OPEN correction at the specified measurement point. (No Query)

Equivalent key

[Meas Setup] - CORRECTION - FREQ - MEAS OPEN

:CORRection:SPOT[1-201]:SHORT[:EXECute]

Syntax

:CORRection:SPOT[1-201]:SHORT[:EXECute]

Description

Executes SHORT correction at the specified measurement point. (No Query)

Equivalent key

[Meas Setup] - CORRECTION - FREQ - MEAS SHORT

:CORRection:SPOT[1-201]:STATE

Syntax

:CORRection:SPOT[1-201]:STATE {ON|OFF|1|0}
:CORRection:SPOT[1-201]:STATE?

Description

Enables the specified measurement point.

Parameter

	Description
ON or 1	Enables the specified measurement point
OFF or 0 (Preset value)	Disables the specified measurement point

Equivalent key

[Meas Setup] - CORRECTION - FREQ - ON
[Meas Setup] - CORRECTION - FREQ - OFF

:CORRection:USE[:CHANnel]

Syntax :CORRection:USE[:CHANnel] <channel>
:CORRection:USE[:CHANnel]?

Description Selects the channel number to be used for the Scanner I/F MULTI mode.

Parameter

	<channel>
Range	0 to 127
Preset value	0

Equivalent key [Meas Setup] - CORRECTION - CH

:CORRection:USE:DATA[:MULTi]

Syntax :CORRection:USE:DATA[:MULTi] <channel>,<open1 A>,<open1 B>,<short1 A>,<short1 B>,<load1 A>,<load1 B>,<open2 A>,<open2 B>,<short2 A>,<short2 B>,<load2 A>,<load2 B>,<.....>,<open 201A>,<open201 B>,<short201 A>,<short201 B>,<load201 A>,<load201 B>
:CORRection:USE:DATA[:MULTi]? <channel>

Description Sets or returns the open/short/load data for the “Multi” correction mode. The data for all 201 test points must be set. Any point with no correction data should be set to 0. A query will return 1,206 data for 201 test points even if there are some frequency points that were turned off. A value of 0 is returned when there are the no correction data.

Parameter

	<channel>
Range	0 to 127

	<open(n) A>,<open(n) B>,<short(n) A>,<short(n) B>,<load(n)A>,<load(n) B>
Preset value	0
Units	OPEN: S; SHORT: ohms; LOAD: Depends on “:CORRection:LOAD:TYPE”

Example of Use

```
Dim Result As String * 50000
vivQueryf(Agte4980a, "CORR:USE:DATA? 0" + vbCrLf, "%t", Result)
```

Equivalent key [Meas Setup] - CORRECTION - MODE - MULTI
[Meas Setup] - CORRECTION - CH

[Meas Setup] - CORRECTION - OPEN A
 [Meas Setup] - CORRECTION - OPEN B
 [Meas Setup] - CORRECTION - SHORT A
 [Meas Setup] - CORRECTION - SHORT B
 [Meas Setup] - CORRECTION - LOAD A
 [Meas Setup] - CORRECTION - LOAD B

:CORRection:USE:DATA:SINGle

Syntax :CORRection:USE:DATA:SINGle <open1 A>,<open1 B>,<short1 A>,<short1 B>,<load1 A>,<load1 B>,<open2 A>,<open2 B>,<short2 A>,<short2 B>,<load2 A>,<load2 B>,<.....>,<open201 A>,<open201 B>,<short201 A>,<short201 B>,<load201 A>,<load201 B>

:CORRection:USE:DATA:SINGle?

Description Sets or returns the open/short/load data for the “Single” correction mode. The data for all 201 test must be set. Any point with no correction data should be set to 0. A query will return 1,206 data for the 201 test points, even if there are some frequency points that were turned off. A value of 0 is returned when there are no correction data.

Parameter

	<open(n) A>,<open(n) B>,<short(n) A>,<short(n) B>,<load(n)A>,<load(n) B>
Preset value	0
Unit	OPEN: S; SHORT: ohms; LOAD: Depends on :CORRection:LOAD:TYPE

Example of Use

```
Dim Result As String * 50000
viVQueryf(Agte4980a, "CORR:USE:DATA:SING?" + vbLf, "%t", Result)
```

Equivalent key [Meas Setup] - CORRECTION - MODE - SINGLE
 [Meas Setup] - CORRECTION - OPEN A
 [Meas Setup] - CORRECTION - OPEN B
 [Meas Setup] - CORRECTION - SHORT A
 [Meas Setup] - CORRECTION - SHORT B
 [Meas Setup] - CORRECTION - LOAD A
 [Meas Setup] - CORRECTION - LOAD B

:CURRent[:LEVel]

Syntax :CURRent[:LEVel] <numeric>
 :CURRent[:LEVel]?

Description Sets the current level for the measurement signal. If the signal is set using :VOLTage[:LEVel], the query command returns error No. 230.

Parameter

	<Numeric>
Range	0 to 100m*1
Unit	A
Resolution	1 μ

*1. Depending on the DC Bias level.

Equivalent key [Display Format] - MEAS DISPLAY - LEVEL
[Meas Setup] - MEAS SETUP - LEVEL

:DISPlay:CClear

Syntax :DISPlay:CClear

Description Clears errors or caution messages from the display. (No Query)

Equivalent key No equivalent key is available on the front panel.

:DISPlay:ENABLE

Syntax :DISPlay:ENABLE {ON|OFF|1|0}

:DISPlay:ENABLE?

Description Enables display updates

Parameter

	Description
ON or 1 (Preset value)	Enables display updates
OFF or 0	Disables display updates. The display will be blank.

Equivalent key [Display Format] - DISPLAY BLANK

:DISPlay:LINE

Syntax :DISPlay:LINE <String>

:DISPlay:LINE?

Description Enters arbitrary comments containing up to 30 ASCII characters in the comment field. The string "USER COMMENT" is displayed if this is empty.

Parameter

	<String>
Preset value	"" (NULL)

Equivalent key

[Meas Setup] - MEAS SETUP - USER COMMENT - ADD CHAR
 [Meas Setup] - MEAS SETUP - USER COMMENT - ENTER
 [Meas Setup] - MEAS SETUP - USER COMMENT - NEXT
 [Meas Setup] - MEAS SETUP - USER COMMENT - PREV

:DISPlay:PAGE

Syntax

:DISPlay:PAGE
 {MEASurement|BNUmber|BCOunt|LIST|MSETup|CSETup|LTABle|LSETup|CATALog|SYSTem|SELF|MLARge|SCONfig|SERVice}
 :DISPlay:PAGE?

Description

Selects the page to be displayed.

Parameter

	Description
MEASurement (Preset value)	Sets displayed page to <MEAS DISPLAY>
BNUmber	Sets displayed page to <BIN No. DISPLAY>
BCOunt	Sets displayed page to <BIN COUNT DISPLAY>
LIST	Sets displayed page to <LIST SWEEP DISPLAY>
MSETup	Sets displayed page to <MEAS SETUP>
CSETup	Sets displayed page to <CORRECTION>
LTABle	Sets displayed page to <LIMIT TABLE SETUP>
LSETup	Sets displayed page to <LIST SWEEP SETUP>
CATALog	Sets displayed page to <CATALOG>
SYSTem	Sets displayed page to <SYSTEM INFO>
SELF	Sets display page to <SELF TEST>
MLARge	Sets page to display measurement results in large characters
SCONfig	Sets displayed page to <SYSTEM CONFIG>
SERVice	Sets displayed page to <SERVICE>

Equivalent key

[Display Format] - DISPLAY FORMAT

[Display Format] - BIN No.
 [Display Format] - BIN COUNT
 [Display Format] - LIST SWEEP
 [Meas Setup] - MEAS SETUP
 [Meas Setup] - CORRECTION
 [Meas Setup] - LIMIT TABLE
 [Meas Setup] - LIST SETUP
 [Save/Recall]
 [System] - SYSTEM INFO
 [System] - SYSTEM CONFIG
 [System] - SELF TEST
 [System] - SERVICE

:DISPlay[:WINDow]:TEXT[1-2][:DATA]:FMSD:DATA

Syntax :DISPlay[:WINDow]:TEXT[1-2][:DATA]:FMSD:DATA <most significant digit>
 :DISPlay[:WINDow]:TEXT[1-2][:DATA]:FMSD:DATA?

Description Selects the most significant digit in the fixed decimal point mode. If the measurement function is set to D, Q, Td, %, this command does nothing.

Parameter

	<most significant digit>
Range	1a 10a 100a 1f 10f 100f 1p 10p 100p 1n 10n 100n 1u 10u 100u 1m 10m 100m 1 10 100 1k 10k 100k 1M 10M 100M 1G 10G 100G 1T 10T 100T 1P 10P 100P 1E
Preset value	1n

Equivalent key [Display Format] - Fixed Decimal Point Menu - D.P. POS INCR +
 [Display Format] - Fixed Decimal Point Menu - D.P. POS INCR -

:DISPlay[:WINDow]:TEXT[1-2][:DATA]:FMSD[:STATe]

Syntax :DISPlay[:WINDow]:TEXT[1-2][:DATA]:FMSD[:STATe] {ON|OFF|1|0}
 :DISPlay[:WINDow]:TEXT[1-2][:DATA]:FMSD[:STATe]?

Description Enables the fixed decimal point mode.

Parameter

	Description
ON or 1	Enables the fixed decimal point mode
OFF or 0 (Preset value)	Disables the fixed decimal point mode

Equivalent key [Display Format] - Fixed Decimal Point Menu - D.P. AUTO
[Display Format] - Fixed Decimal Point Menu - D.P. FIX

:FETCh[:IMPedance]:CORReCted?

Syntax :FETCh[:IMPedance]:CORReCted?

Description Returns a complex measurement result (R-X format) after correction. (Query Only)

Equivalent key No equivalent key is available on the front panel.

:FETCh[:IMPedance][:FORMatted]?

Syntax :FETCh[:IMPedance][:FORMatted]?

Description Returns a measurement result with the selected measurement function. See the “Read Measurement Results” on page 374. (Query Only)

Equivalent key No equivalent key is available on the front panel.

:FETCh:SMONitor:IAC?

Syntax :FETCh:SMONitor:IAC?

Description Returns the latest measured data for the AC current monitor. In case of Vdc-Idc measurement, 0 is returned. (Query Only)

Equivalent key No equivalent key is available on the front panel.

:FETCh:SMONitor:IDC?

Syntax :FETCh:SMONitor:IDC?

Description Returns the latest measured data for the DC current monitor. If the current-level monitor is set to OFF, 0.0 is returned. (Query Only)

Equivalent key No equivalent key is available on the front panel.

:FETCh:SMONitor:VAC?

Syntax :FETCh:SMONitor:VAC?

Description Returns the latest measured data for the AC voltage monitor. In case of Vdc-Idc measurement, 0 is returned. (Query Only)

Equivalent key No equivalent key is available on the front panel.

:FETCh:SMONitor:VDC?

Syntax :FETCh:SMONitor:VDC?

Description Returns the latest measured data for the DC voltage monitor. If the voltage-level monitor is set to OFF, 0.0 is returned. (Query Only)

Equivalent key No equivalent key is available on the front panel.

:FORMat:ASCii:LONG

Syntax :FORMat:ASCii:LONG {ON|OFF|1|0}
:FORMat:ASCii:LONG?

Description Enables the long format (+0.000000000E+00). This is applied to the returned values of :FETCh[:IMPedance][:FORMatted]?/:MEMory:READ?/*TRG.

Parameter

	Description
ON or 1	Long format
OFF or 0 (Preset value)	Short Format

Equivalent key No equivalent key is available on the front panel.

:FORMat:BORDER

Syntax :FORMat:BORDER {NORMAL|SWAPped}
:FORMat:BORDER?

Description When the data transfer format is set to the binary type, this command sets the transfer order of each byte in data (byte order).

Parameter

	Description
NORMAL (Preset value)	Specifies the byte order in which transfer starts from the byte that includes the MSB (Most Significant Bit)
SWAPped	Specifies the byte order in which transfer starts from the byte that includes the LSB (Least Significant Bit)

Equivalent key No equivalent key is available on the front panel.

:FORMat[:DATA]

Syntax :FORMat[:DATA] { ASCii|REAL[,64]}
:FORMat[:DATA]?

Description Selects the data transfer format (Binary or ASCII). This is applied to the returned values of :FETCh[:IMPedance][:FORMatted]?:MEMory:READ?/*TRG. In the case of the binary mode, any value other than [,64] is acceptable but ignored. A query returns REAL, 64 in case of using the binary format.
See the chapter on program examples for data transfer.

Parameter

	Description
ASCii (Preset value)	Sets the transfer mode to ASCII
REAL	Sets the transfer mode to Binary

Example of Use `viVPrintf(Agte4980a, ":FORM REAL" + vbLf, 0)`

Equivalent key No equivalent key is available on the front panel.

:FREQuency[:CW]

Syntax :FREQuency[:CW] <numeric>
:FREQuency[:CW]?

Description Sets the frequency for normal measurement.

Parameter

	<Numeric>
Range	20 to 2M
Preset value	1k
Unit	Hz
Resolution	Depends on the setting frequency.

Equivalent key [Display Format] - DISPLAY FORMAT - FREQ
[Meas Setup] - MEAS SETUP - FREQ

:FUNction:DCResistance:RANGe:AUTO

Syntax :FUNction:DCResistance:RANGe:AUTO {ON|OFF|1|0}

:FUNction:DCResistance:RANGe:AUTO?

Description Enables the auto range function for DCR measurement.

Parameter

	Description
ON or 1 (Preset value)	DCR measurement auto range ON
OFF or 0	DCR measurement auto range OFF

Equivalent key [Meas Setup] - MEAS SETUP - DCR RNG - AUTO
[Meas Setup] - MEAS SETUP - DCR RNG - HOLD

:FUNction:DCResistance:RANGe[:VALue]

Syntax :FUNction:DCResistance:RANGe[:VALue] <numeric>
:FUNction:DCResistance:RANGe[:VALue]?

Description Selects the DCR measurement range. This command turns the auto range function OFF.

Parameter

	<Numeric>
Range	10 100 1k 10k 100k
Preset value	100
Unit	ohms

Equivalent key [Meas Setup] - MEAS SETUP - DCR RNG

:FUNction:DEV[1-2]:MODE

Syntax :FUNction:DEV[1-2]:MODE {ABSolute|PERCent|OFF}
:FUNction:DEV[1-2]:MODE?

Description Selects the deviation measurement mode.

Parameter

	Description
ABSolute	Sets the deviation measurement mode to “ABS”
PERCent	Sets the deviation measurement mode to “%”
OFF(Preset value)	Disables the deviation measurement mode

Equivalent key [Meas Setup] - MEAS SETUP - DEV A - ABS
 [Meas Setup] - MEAS SETUP - DEV A - %
 [Meas Setup] - MEAS SETUP - DEV A - OFF
 [Meas Setup] - MEAS SETUP - DEV B - ABS
 [Meas Setup] - MEAS SETUP - DEV B - %
 [Meas Setup] - MEAS SETUP - DEV B - OFF

:FUNCTION:DEV[1-2]:REFERENCE:FILL

Syntax :FUNCTION:DEV[1-2]:REFERENCE:FILL

Description Executes a single measurement and enters two measured values (the primary and secondary parameters) into each of the reference values for deviation measurement. FUNC:DEV1:REF:FILL and FUNC:DEV2:REF:FILL are the identical. (No Query)
 The E4980A operates in the same way with either DEV1 or DEV2.

Equivalent key [Meas Setup] - MEAS SETUP - REF A - MEASURE
 [Meas Setup] - MEAS SETUP - REF B - MEASURE

:FUNCTION:DEV[1-2]:REFERENCE[:VALUE]

Syntax :FUNCTION:DEV[1-2]:REFERENCE[:VALUE] <numeric>
 :FUNCTION:DEV[1-2]:REFERENCE[:VALUE]?

Description Sets the reference value for deviation measurement.

Parameter

	<Numeric>
Preset value	0
Unit	Depends on :FUNCTION:IMPedance[:TYPE].

Equivalent key [Meas Setup] - MEAS SETUP - REF A
 [Meas Setup] - MEAS SETUP - REF B

:FUNCTION:IMPedance:RANGe:AUTO

Syntax :FUNCTION:IMPedance:RANGe:AUTO {ON|OFF|1|0}
 :FUNCTION:IMPedance:RANGe:AUTO?

Description Enables the auto-range function for impedance measurement.

Parameter

	Description
ON or 1 (Preset value)	Auto range ON
OFF or 0	Auto range OFF

Equivalent key

[Display Format] - MEAS DISPLAY - RANGE - AUTO
 [Display Format] - MEAS DISPLAY - RANGE - HOLD
 [Meas Setup] - MEAS SETUP - RANGE - AUTO
 [Meas Setup] - MEAS SETUP - RANGE - HOLD

:FUNction:IMPedance:RANGe[:VALue]

Syntax

:FUNction:IMPedance:RANGe[:VALue] <numeric>
 :FUNction:IMPedance:RANGe[:VALue]?

Description

Selects the impedance measurement range. This command turns the auto range function OFF.

Parameter

	<Numeric>
Range	100m 1 10 100 300 1k 3k 10k 30k 100k
Preset value	100
Unit	ohms

Equivalent key

[Display Format] - MEAS DISPLAY - RANGE
 [Meas Setup] - MEAS SETUP - RANGE

:FUNction:IMPedance[:TYPE]

Syntax

:FUNction:IMPedance[:TYPE]
 {CPD|CPQ|CPG|CPRP|CSD|CSQ|CSRS|LPD|LPQ|LPG|LPRP|LPRD|LSD|LSQ|LSRS|LSRD|RX|ZTD|ZTR|GB|YTD|YTR|VDID}
 :FUNction:IMPedance[:TYPE]?

Description

Selects the measurement function.

Parameter

	Description
CPD(Preset value)	Sets the Impedance Parameter Type to “Cp-D”

	Description
CPQ	Sets the Impedance Parameter Type to “Cp-Q”
CPG	Sets the Impedance Parameter Type to “Cp-G”
CPRP	Sets the Impedance Parameter Type to “Cp-Rp”
CSD	Sets the Impedance Parameter Type to “Cs-D”
CSQ	Sets the Impedance Parameter Type to “Cs-Q”
CSRS	Sets the Impedance Parameter Type to “Cs-Rs”
LPD	Sets the Impedance Parameter Type to “Lp-D”
LPQ	Sets the Impedance Parameter Type to “Lp-Q”
LPG	Sets the Impedance Parameter Type to “Lp-G”
LPRP	Sets the Impedance Parameter Type to “Lp-Rp”
LPRD ^{*1}	Sets the Impedance Parameter Type to “Lp-Rdc”
LSD	Sets the Impedance Parameter Type to “Ls-D”
LSQ	Sets the Impedance Parameter Type to ‘Ls-Q’
LSRS	Sets the Impedance Parameter Type to “Ls-Rs”
LSRD ^{*1}	Sets the Impedance Parameter Type to “Ls-Rdc”
RX	Sets the Impedance Parameter Type to “R-X”
ZTD	Sets the Impedance Parameter Type to “Z-thd”
ZTR	Sets the Impedance Parameter Type to “Z-thr”
GB	Sets the Impedance Parameter Type to “G-B”
YTD	Sets the Impedance Parameter Type to “Y-thd”
YTR	Sets the Impedance Parameter Type to “Y-thr”
VDID	Sets the Impedance Parameter Type to “Vdc-Idc”

*1. This can be set only when option 001 is installed.

Equivalent key The softkeys of [Display Format] - MEAS DISPLAY - FUNC field
 The softkeys of [Meas Setup] - MEAS SETUP - FUNC field

:FUNCTION:SMONitor:IAC[:STATe]

Syntax :FUNCTION:SMONitor:IAC[:STATe] {ON|OFF|1|0}
 :FUNCTION:SMONitor:IAC[:STATe]?

Description Does nothing. The E4980A always has the AC current-level monitor turned ON. This function is provided because of its command compatibility with 4284A.

Parameter

	Description
ON or 1 (Preset value)	Does nothing
OFF or 0	Does nothing

Equivalent key No equivalent key is available on the front panel.

:FUNCTION:SMONitor:IDC[:STATe]

Syntax :FUNCTION:SMONitor:IDC[:STATe] {ON|OFF|1|0}
:FUNCTION:SMONitor:IDC[:STATe]?

Description Enables the DC current-level monitor function.

NOTE This is available when option 001 is installed.

Parameter

	Description
ON or 1	DC current monitor function ON
OFF or 0 (Preset value)	DC current monitor function OFF

Equivalent key [Meas Setup] - MEAS SETUP - IDC MON - ON
[Meas Setup] - MEAS SETUP - IDC MON - OFF

:FUNCTION:SMONitor:VAC[:STATe]

Syntax :FUNCTION:SMONitor:VAC[:STATe] {ON|OFF|1|0}
:FUNCTION:SMONitor:VAC[:STATe]?

Description Does nothing. The E4980A always has its AC voltage-level monitor turned ON. This function is provided because of its command compatibility with 4284A.

Parameter

	Description
ON or 1 (Preset value)	Does nothing
OFF or 0	Does nothing

Equivalent key No equivalent key is available on the front panel.

:FUNCTION:SMONitor:VDC[:STATE]

Syntax :FUNCTION:SMONitor:VDC[:STATE] {ON|OFF|1|0}
:FUNCTION:SMONitor:VDC[:STATE]?

Description Enables the DC voltage-level monitor function.

NOTE This is available when option 001 is installed.

Parameter

	Description
ON or 1	DC voltage monitor function ON
OFF or 0 (Preset value)	DC voltage monitor function OFF

Equivalent key [Meas Setup] - MEAS SETUP - VDC MON - ON
[Meas Setup] - MEAS SETUP - VDC MON - OFF

:HCOPY:SDUMp:DATA

Syntax :HCOPY:SDUMp:DATA

Description Outputs screen image to the controller. (Query Only)

Example of Use

```
Dim Nop As Long
Dim GifData(10000) As Byte
Dim paramsArray(2) As Long
Dim i As Integer

Nop = UBound(GifData) - LBound(GifData) + 1
paramsArray(0) = VarPtr(Nop)
paramsArray(1) = VarPtr(GifData(0))

Call viVPrintf(Agte4980a, ":HCOPY:SDUMP:DATA?" + vbLf, 0)
Call viVScanf(Agte4980a, "%#b", paramsArray(0))

Open "C:\TEST.gif" For Binary As #1
For i = 0 To Nop - 1
    Put #1, , GifData(i)
Next i
Close
```

Equivalent key No equivalent key is available on the front panel.

NOTE Pressing [Save/Recall] - SAVE DISPLAY key saves the current screen image into the USB memory.

:INITiate:CONTInuous

Syntax :INITiate:CONTInuous {ON|OFF|1|0}
:INITiate:CONTInuous?

Description Enables the automatic trigger to change state from the “Idle” state to the “Wait for Trigger” state. Refer to the chapter on Remote Control.

Parameter

	Description
ON or 1	Enables automatic trigger state change
OFF or 0 (Preset value)	Disables automatic trigger state change

Equivalent key No equivalent key is available on the front panel.

:INITiate[:IMMEDIATE]

Syntax :INITiate[:IMMEDIATE]

Description Initiates the trigger to change from the “Idle” state to the “Wait for Trigger” state one time. Refer to the chapter on Remote Control. (No Query)

Equivalent key No equivalent key is available on the front panel.

:LIST:BAND[1-201]

Syntax :LIST:BAND[1-201] {A|B|OFF},<low>,<high>

:LIST:BAND[1-201]?

Description Sets the limit values of the limit function for the list sweep measurement. When A or B is the parameter, both lower and the upper limit should be input. If either of them is not input, error No. 109 is returned. In the case of OFF,<low>,<high> are optional.

Parameter

	Description
A	Sets limit test target to A (Primary parameter)
B	Sets limit test target to B (Secondary parameter)
OFF (Preset value)	Sets limit test target to OFF

	<low>,<high>
Preset value	Query returns -9.9E37, +9.9E37 for <low>,<high>,respectively in the case of OFF.
Unit	Depends on :FUNCTION:IMPedance[:TYPE]

Equivalent key [Meas Setup] - LIST SETUP - LMT - A
 [Meas Setup] - LIST SETUP - LMT - B
 [Meas Setup] - LIST SETUP - LMT - --
 [Meas Setup] - LIST SETUP - LOW
 [Meas Setup] - LIST SETUP - HIGH

:LIST:BIAS:CURRENT

Syntax :LIST:BIAS:CURRENT <point 1>,<point 2>,... ,<point n>
 :LIST:BIAS:CURRENT?

Description Clears the previous list sweep table, sets DC current sweep as the list sweep parameter, and sets DC current points for the DC current list sweep. If the list sweep is not set for DC current, the query command returns error No. 230. The value 9.9E37 should be set for any empty points.

Parameter

	<point n>
Range of n	1 to 201
Unit	A

Equivalent key [Meas Setup] - LIST SETUP - BIAS[A]

:LIST:BIAS:VOLTage

Syntax :LIST:BIAS:VOLTage <point 1>,<point 2>,... ,<point n>
 :LIST:BIAS:VOLTage?

Description Clears the previous list sweep table, sets DC voltage sweep as the list sweep parameter, and sets DC voltage points for the DC voltage list sweep. If the list sweep is not set for DC voltage, the query command returns error No. 230. The value 9.9E37 should be set for any empty points.

Parameter

	<point n>
Range of n	1 to 201

	<point n>
Unit	V

Equivalent key [Meas Setup] - LIST SETUP - BIAS[V]

:LIST:CLEar:ALL

Syntax :LIST:CLEar:ALL

Description Clears the list sweep setup. (No Query)

Equivalent key [Meas Setup] - LIST SETUP - No. - CLEAR TABLE

:LIST:CURRent

Syntax :LIST:CURRent <point 1>,<point 2>,... ,<point n>
:LIST:CURRent?

Description Clears the previous list sweep table, sets AC current sweep as the list sweep parameter, and sets AC current points for the AC current list sweep. If the list sweep is not set for AC current, the query command returns error No. 230. The value 9.9E37 should be set for any empty points.

Parameter

	<point n>
Range of n	1 to 201
Unit	A

Example of Use `viVPrintf(Agte4980a, ":LIST:CURR 0.01, 9.9e37, 0.02" + vbLf, 0)`

Equivalent key [Meas Setup] - LIST SETUP - LEVEL[A]

:LIST:DCSource:VOLTage

Syntax :LIST:DCSource:VOLTage <point 1>,<point 2>,... ,<point n>
:LIST:DCSource:VOLTage?

Description Clears the previous list sweep table, sets DC source voltage sweep as the list sweep parameter, and sets DC source voltage points for the DC source voltage list sweep. If the list sweep is not set for DC source voltage, the query command returns error No. 230. The value 9.9E37 should be set for any empty points.

Parameter

	<point n>
Range of n	1 to 201
Unit	A

Equivalent key [Meas Setup] - LIST SETUP - DC SRC[V]

:LIST:FREQuency

Syntax :LIST:FREQuency <point 1>,<point 2>,...,<point n>
:LIST:FREQuency?

Description Clears the previous list sweep table, sets frequency sweep as the list sweep parameter, and sets frequency points for the frequency list sweep. If the list sweep is not set for frequency, the query command returns error No. 230. The value of 9.9E37 should be set for any empty points.

Parameter

	<point n>
Range of n	1 to 201
Unit	Hz

Example of Use `viVPrintf(Agte4980a, ":LIST:FREQ 1e2,2e2,5e2,9.9e37,1e3" + vbLf, 0)`

Equivalent key [Meas Setup] - LIST SETUP - FREQ[Hz]

:LIST:MODE

Syntax :LIST:MODE {SEQuence|STEPped}
:LIST:MODE?

Description Selects the sweep mode for the list sweep measurement function. In the case of SEQ, one trigger makes all sweep point measurements. In the case of STEP, one trigger makes single point-by-point measurements.

Parameter

	Description
SEQuence (Preset value)	Sets the list sweep mode to sequence mode
STEPped	Sets the list sweep mode to step mode

Equivalent key [Meas Setup] - LIST SETUP - MODE - SEQ

[Meas Setup] - LIST SETUP - MODE - STEP

:LIST:SEQuence:TSTamp:CLEar

Syntax	:LIST:SEQuence:TSTamp:CLEar
Description	Clears the time stamp of the list sweep executed in sequential (SEQ) mode. (No Query)
Equivalent key	No equivalent key is available on the front panel.

:LIST:SEQuence:TSTamp:DATA

Syntax	:LIST:SEQuence:TSTamp:DATA
Description	Returns the time stamp for each measurement point of the list sweep executed in sequential (SEQ) mode. The time stamp indicates the measurement start time at each point from trigger detection to each list point. If no time stamp data exist, error No. 230 is returned. (Query Only)
Example of Use	<pre>Dim Result As String * 10000 viVQueryf(Agte4980a, ":LIST:SEQ:TST:DATA?" + vbLf, "%t", Result)</pre>
Equivalent key	No equivalent key is available on the front panel.

:LIST:STIMulus:DATA

Syntax	:LIST:STIMulus:DATA <Point 1 1stSTIM>,<Point 1 2ndSTIM>,<Point 2 1stSTIM>,<Point 2 2ndSTIM>.....,<point n 1stSTIM>,<point n 2ndSTIM> :LIST:STIMulus:DATA?
Description	Sets the list sweep with two parameters (first and secondary parameters). This command allows you to sweep with two parameters. For example, you can sweep at point no.1 with 1 kHz/1 V, point no. 2 with 2 kHz/1.1 V, and point no. 3 with 3 kHz/0.9 V. Both first and second parameters must be set unless the second parameter of :LIST:STIMulus:TYPE command is set to NONE. The value 9.9E37 should be set for any empty points. When the IRANge is selected as the secondary parameter in the :LIST:STIMulus:TYPE command, the value for <Point n 2ndSTIM> can selected within the value of :FUNctioN:IMPedance:RANge[:VALue].

Parameter

	<Point n 1stSTIM>,<Point n 2ndSTIM>*1
Range of n	1 to 201
Unit	Depends on :LIST:STIMulus:TYPE

*1. When the second parameter of :LIST:STIMulus:TYPE command is set to NONE, this parameter is not needed.

Example of Use

```
viVPrintf(Agte4980a, "LIST:STIM:TYPE FREQ, VOLT" + vbLf, 0)
viVPrintf(Agte4980a, "LIST:STIM:DATA 1E3, 1, 2E3, 1.1, 3E3, 0.9" +
vbLf, 0)
```

Equivalent key No equivalent key is available on the front panel.

:LIST:STIMulus:MDATa?

Syntax :LIST:STIMulus:MDATa?

Description Returns actual stimulus values for a list sweep with two parameters. This command allows you to know the actual applied values after the auto polarity function works. (Query Only)

Equivalent key No equivalent key is available on the front panel.

:LIST:STIMulus:TYPE

Syntax :LIST:STIMulus:TYPE
{FREQuency|VOLTagE|CURRent|BVOLtagE|BCURrent|DCSVoltage},{NONE|IRANge|FREQuency|VOLTagE|CURRent|BVOLtagE|BCURrent|DCSVoltage}
:LIST:STIMulus:TYPE?

Description Selects the parameter types for the list sweep with two parameters. If you do not want to specify the second parameter, enter NONE for it. When you do specify the second parameter, its measurement range can be set.

Parameter

	First Parameter
FREQuency (Preset value)	Selects frequency as the first stimulus parameter
VOLTagE	Selects voltage as the first stimulus parameter
CURRent	Selects current as the first stimulus parameter
BVOLtagE	Selects bias voltage as the first stimulus parameter
BCURrent	Selects bias current as the first stimulus parameter
DCSVoltage	Selects DC source voltage as the first stimulus parameter

	Second Parameter
NONE (Preset value)	Selects no second stimulus parameter. The same operation is performed as the :LIST:FREQuency, :LIST:CURRent and so on according to the first stimulus parameter.
IRANge	Selects impedance range as the second stimulus parameter.
FREQuency	Selects frequency as the second stimulus parameter

	Second Parameter
VOLTage	Selects voltage as the second stimulus parameter
CURRent	Selects current as the second stimulus parameter
BVOLTage	Selects bias voltage as the second stimulus parameter
BCURrent	Selects bias current as the second stimulus parameter
DCSVoltage	Selects DC source voltage as the second stimulus parameter

Example of Use `viVPrintf(Agte4980a, "LIST:STIM:TYPE FREQ, VOLT" + vbLf, 0)`
`viVPrintf(Agte4980a, "LIST:STIM:DATA 1E3, 1, 2E3, 1.1, 3E3, 0.9" + vbLf, 0)`

Equivalent key No equivalent key is available on the front panel.

:LIST:VOLTage

Syntax `:LIST:VOLTage <point 1>,<point 2>,...,<point n>`
`:LIST:VOLTage?`

Description Clears the previous list sweep table, sets AC voltage sweep as the list sweep parameter, and sets AC voltage points for the AC voltage list sweep. If the list sweep is not set for AC voltage, the query command returns error No. 230. The value 9.9E37 should be set for any empty points.

Parameter

	<point n>
Range of n	1 to 201
Unit	V

Example of Use `viVPrintf(Agte4980a, ":LIST:VOLT 0.5, 0.8, 1, 9.9e37, 1.5" + vbLf, 0)`

Equivalent key [Meas Setup] - LIST SETUP - LEVEL[V]

:MEMory:CLEar

Syntax `:MEMory:CLEar DBUF`

Description Clears and disables the data buffer memory. After this command is executed, measurement data will not be stored in the data buffer memory until execution of the :FILL command. (No Query)

Equivalent key [Save/Recall] - SAVE DATA - SAVE & STOP
 This key is a combination of both :MEMory:READ? and :MEMory:CLEar.

:MEMory:DIM

Syntax :MEMory:DIM DBUF,<numeric>
:MEMory:DIM?

Description Clears the data buffer memory, and sets the data buffer memory's size. An example of data buffer memory is shown in the chapter on program examples.

Parameter

	<Numeric>
Range	1 to 201
Preset value	201
Resolution	1

Equivalent key No equivalent key is available on the front panel.

:MEMory:FILL

Syntax :MEMory:FILL DBUF

Description Enables the data buffer memory to store measurement data. After execution of this command, all measurement data will be stored in the data buffer memory. If this has already been enabled, this command will do nothing. (No Query)

Equivalent key [Save/Recall] - SAVE DATA - START LOG

:MEMory:READ?

Syntax :MEMory:READ? DBUF

Description Places the data in the data buffer memory into the output buffer. The output format of this command is the same as the one for FETC:IMP?. In the preset state, "9.90000E+37,+9.90000E+37,-1,+0" is returned the number of times specified by :MEMory:DIM. When the data buffer memory is not filled to the specified size (specified by the :MEMory:DIM command), "9.90000E+37,+9.90000E+37,-1,+0" remains for the rest of the data locations. (Query Only)

Equivalent key [Save/Recall] - SAVE DATA - SAVE & STOP
This key is a combination of both :MEMory:READ? and :MEMory:CLEar.

:MMEMory:DELEte[:REGister]

Syntax :MMEMory:DELEte[:REGister] <numeric>

Description Deletes the state from the memories. Numbers 0 to 9 are located in the internal memory, while Nos. 10 to 19 are situated in the external USB memory. (No Query)

Parameter

	<Numeric>
Range	0 to 19
Resolution	1

Equivalent key [Save/Recall] - No. - DELETE

:MMEMory:LOAD:STATe[:REGister]

Syntax :MMEMory:LOAD:STATe[:REGister] <numeric>

Description Loads the state from the memories. Numbers 0 to 9 are located in the internal memory, while Nos. 10 to 19 are situated in the external USB memory. (No Query)

Parameter

	<Numeric>
Range	0 to 19
Resolution	1

Equivalent key [Save/Recall] - No. - RECALL

:MMEMory:STORE:STATe[:REGister]

Syntax :MMEMory:STORE:STATe[:REGister] <numeric>

Description Stores the state to the memories. Numbers 0 to 9 are located in the internal memory, while Nos. 10 to 19 are situated in the external USB memory. Number 10 is automatically recalled. (No Query)

Parameter

	<Numeric>
Range	0 to 19
Resolution	1

Equivalent key [Save/Recall] - No. - SAVE

:OUTPut:DC:ISOLation:LEVel:AUTO

Syntax :OUTPut:DC:ISOLation:LEVel:AUTO {ON|OFF|1|0}

:OUTPut:DC:ISOLation:LEVel:AUTO?

Description Enables the auto range function for DCI.

Parameter

	Description
ON or 1 (Preset value)	Enables the auto range function for DCI
OFF or 0	Disables the auto range function for DCI

Equivalent key [Meas Setup] - MEAS SETUP - DCI RNG - AUTO
[Meas Setup] - MEAS SETUP - DCI RNG - HOLD

:OUTPut:DC:ISOLation:LEVel:VALue

Syntax :OUTPut:DC:ISOLation:LEVel:VALue <numeric>
:OUTPut:DC:ISOLation:LEVel:VALue?

Description Selects DC isolation range. This command turns the auto range function OFF.

Parameter

	<Numeric>
Range	20 μ 200 μ 2 m 20 m 100 m
Preset value	20 m
Unit	A

Equivalent key [Meas Setup] - MEAS SETUP - DCI RNG

:OUTPut:DC:ISOLation[:STATe]

Syntax :OUTPut:DC:ISOLation[:STATe] {ON|OFF|1|0}
:OUTPut:DC:ISOLation[:STATe]?

Description Enables DC Isolation.

Parameter

	Description
ON or 1	Enables DC Isolation
OFF or 0 (Preset value)	Disables DC Isolation

Equivalent key [Meas Setup] - MEAS SETUP - DCI ISO - ON
[Meas Setup] - MEAS SETUP - DCI ISO - OFF

:OUTPut:HPOWer

Syntax :OUTPut:HPOWer {ON|OFF|1|0}

:OUTPut:HPOWer?

Description Does nothing. This function is provided because of its command compatibility with 4284A.

Parameter

	Description
ON or 1	Does nothing
OFF or 0 (Preset value)	Does nothing

Equivalent key No equivalent key is available on the front panel.

:SOURce:DCSource:STATe

Syntax :SOURce:DCSource:STATe {ON|OFF|1|0}

:SOURce:DCSource:STATe?

Description Enables the DC Source. The DC source is automatically turned OFF after recalling the state from memory. When DC Source is set to ON, DC Source voltage that has been set with :SOURce:DCSource:VOLTage[:LEVel] is output.

NOTE This is available when option 001 is installed.

Parameter

	Description
ON or 1	Enables the DC Source
OFF or 0 (Preset value)	Disables the DC Source

Equivalent key [DC Source]

:SOURce:DCSource:VOLTage[:LEVel]

Syntax :SOURce:DCSource:VOLTage[:LEVel] <numeric>

:SOURce:DCSource:VOLTage[:LEVel]?

Description Sets the DC source's voltage level

NOTE This is available when option 001 is installed.

Parameter

	<Numeric>
Range	-10 to 10
Preset value	0
Unit	V
Resolution	1 m

Equivalent key [Meas Setup] - MEAS SETUP - DC SRC

:STATus:OPERation:CONDition?

Syntax :STATus:OPERation:CONDition?

Description Returns the value of the Operation Status Condition register. (Query Only)

Equivalent key No equivalent key is available on the front panel.

:STATus:OPERation:ENABLE

Syntax :STATus:OPERation:ENABLE <numeric>
:STATus:OPERation:ENABLE?

Description Sets the value of the Operation Status Enable register.

Parameter

	<Numeric>
Range	-32,768 to 32,767
Preset value	0

Equivalent key No equivalent key is available on the front panel.

:STATus:OPERation[:EVENT]

Syntax :STATus:OPERation[:EVENT]

Description Returns the value of the Operation Status Event register. (Query Only)

Equivalent key No equivalent key is available on the front panel.

:SYSTem:BEEPer[:IMMediate]

Syntax :SYSTem:BEEPer[:IMMediate]

Description Produces a beep sound. Even if the beep sound is disabled by the :SYSTEM:BEEPer:STAtE command, a beep sound is still produced. (No Query)

Equivalent key No equivalent key is available on the front panel.

:SYSTEM:BEEPer:STAtE

Syntax :SYSTEM:BEEPer:STAtE {ON|OFF|1|0}
:SYSTEM:BEEPer:STAtE?

Description Enables a beep sound.

Parameter

	Description
ON or 1	Enables a beep sound
OFF or 0 (Preset value)	Disables a beep sound

Equivalent key [System] - SYSTEM CONFIG - BEEPER ENABLED - ON
[System] - SYSTEM CONFIG - BEEPER ENABLED - OFF

:SYSTEM:BEEPer:TONE

Syntax :SYSTEM:BEEPer:TONE <numeric>
:SYSTEM:BEEPer:TONE?

Description Selects a beep sound tone.

Parameter

	<Numeric>
Range	1 to 5
Preset value	3
Resolution	1

Equivalent key [System] - SYSTEM CONFIG - BEEPER TONE - TONE 1
[System] - SYSTEM CONFIG - BEEPER TONE - TONE 2
[System] - SYSTEM CONFIG - BEEPER TONE - TONE 3
[System] - SYSTEM CONFIG - BEEPER TONE - TONE 4
[System] - SYSTEM CONFIG - BEEPER TONE - TONE 5

:SYSTem:COMMunicate:GPIB[:SELF]:ADDRESS

Syntax
:SYSTem:COMMunicate:GPIB[:SELF]:ADDRESS <numeric>
:SYSTem:COMMunicate:GPIB[:SELF]:ADDRESS?

Description Sets the GPIB address.

Parameter

	<Numeric>
Range	0 to 30
Preset value	17
Resolution	1

Equivalent key [System] - SYSTEM CONFIG - GPIB ADDR

:SYSTem:COMMunicate:LAN[:SELF]:ADDRESS

Syntax
:SYSTem:COMMunicate:LAN[:SELF]:ADDRESS <String>
:SYSTem:COMMunicate:LAN[:SELF]:ADDRESS?

Description Sets the static IP address.

Parameter

	<String>
Preset value	"192.168.1.101"

Equivalent key [System] - SYSTEM CONFIG - MANUAL IP ADDR - ENTER

:SYSTem:COMMunicate:LAN[:SELF]:AIP[:STATe]

Syntax
:SYSTem:COMMunicate:LAN[:SELF]:AIP[:STATe] {ON|OFF|1|0}
:SYSTem:COMMunicate:LAN[:SELF]:AIP[:STATe]?

Description Enables automatic IP address setup. The E4980A can obtain an available IP address at 169.254.xxx.xxx.

NOTE This command works with the firmware revision 1.0x. Do not use this command with the firmware revision 2.00 or later.

Parameter

	Description
ON or 1 (Preset value)	Enables automatic IP address setup
OFF or 0	Disables automatic IP address setup

Equivalent key [System] - SYSTEM CONFIG - AUTO-IP ENABLED - ON
[System] - SYSTEM CONFIG - AUTO-IP ENABLED - OFF

:SYSTem:COMMunicate:LAN[:SELF]:CONFigure

Syntax :SYSTem:COMMunicate:LAN[:SELF]:CONFigure { AUTO|MANual }
:SYSTem:COMMunicate:LAN[:SELF]:CONFigure?

Description Selects automatic obtaining or manual setting for the IP address obtaining method.

NOTE This command is available for the firmware revision 2.00 or later.

Parameter

	Description
AUTO (Preset value)	Sets the IP address obtaining method to AUTO
MANual	Sets the IP address obtaining method to MAN

Equivalent key [System] - SYSTEM CONFIG - IP CONFIG - AUTO
[System] - SYSTEM CONFIG - IP CONFIG - MAN

:SYSTem:COMMunicate:LAN[:SELF]:CONTRol

Syntax :SYSTem:COMMunicate:LAN[:SELF]:CONTRol

Description Returns the SOCKET control port number. If the parser is a SOCKET, it will return a number from 5000 to 5100. Otherwise, 0. (Query Only)

Equivalent key No equivalent key is available on the front panel.

:SYSTem:COMMunicate:LAN[:SELF]:CURRent:ADDRess ?

Syntax :SYSTem:COMMunicate:LAN[:SELF]:CURRent:ADDRess?

Description Returns the current IP address. (Query Only)

Equivalent key No equivalent key is available on the front panel.

:SYSTem:COMMunicate:LAN[:SELF]:CURRent:DGATew ay?

- Syntax :SYSTem:COMMunicate:LAN[:SELF]:CURRent:DGATeway?
- Description Returns the current Gateway address. (Query Only)
- Equivalent key No equivalent key is available on the front panel.

:SYSTem:COMMunicate:LAN[:SELF]:CURRent:SMASk?

- Syntax :SYSTem:COMMunicate:LAN[:SELF]:CURRent:SMASk?
- Description Returns the current Subnet Mask. (Query Only)
- Equivalent key No equivalent key is available on the front panel.

:SYSTem:COMMunicate:LAN[:SELF]:DGATeway

- Syntax :SYSTem:COMMunicate:LAN[:SELF]:DGATeway <String>
:SYSTem:COMMunicate:LAN[:SELF]:DGATeway?
- Description Sets the static Gateway address.
- Parameter

	<String>
Preset value	"0.0.0.0"

- Equivalent key [System] - SYSTEM CONFIG - MANUAL GATEWAY - ENTER

:SYSTem:COMMunicate:LAN[:SELF]:DHCP[:STATe]

- Syntax :SYSTem:COMMunicate:LAN[:SELF]:DHCP[:STATe] {ON|OFF|1|0}
:SYSTem:COMMunicate:LAN[:SELF]:DHCP[:STATe]?
- Description Enables DHCP to obtain the IP address from a DHCP server.

NOTE This command works with Firmware version 1.0x. Do not use this command with Firmware version 2.00 or later.

Parameter

	Description
ON or 1 (Preset value)	Enables the DHCP function

	Description
OFF or 0	Disables the DHCP function

Equivalent key [System] - SYSTEM CONFIG - DHCP ENABLED - ON
[System] - SYSTEM CONFIG - DHCP ENABLED - OFF

:SYSTem:COMMunicate:LAN[:SELF]:MAC?

Syntax :SYSTem:COMMunicate:LAN[:SELF]:MAC?

Description Returns the MAC address. (Query Only)

Equivalent key No equivalent key is available on the front panel.

:SYSTem:COMMunicate:LAN[:SELF]:PRESet

Syntax :SYSTem:COMMunicate:LAN[:SELF]:PRESet

Description Presets the network settings and restarts the network. (No Query)

Equivalent key [Preset} - LAN RESET - OK

:SYSTem:COMMunicate:LAN[:SELF]:REStart

Syntax :SYSTem:COMMunicate:LAN[:SELF]:REStart

Description Restarts the network (No Query)

Equivalent key [System] - SYSTEM CONFIG - DHCP ENABLED - RESTART NETWORK*¹
[System] - SYSTEM CONFIG - AUTO-IP ENABLED - RESTART NETWORK*¹
[System] - SYSTEM CONFIG - IP CONFIG - RESTART NETWORK*²
[System] - SYSTEM CONFIG - MANUAL IP ADDR - RESTART NETWORK
[System] - SYSTEM CONFIG - MANUAL SUBNET MASK - RESTART NETWORK
[System] - SYSTEM CONFIG - MANUAL GATEWAY - RESTART NETWORK

:SYSTem:COMMunicate:LAN[:SELF]:SMASk

Syntax :SYSTem:COMMunicate:LAN[:SELF]:SMASk <String>
:SYSTem:COMMunicate:LAN[:SELF]:SMASk?

Description Sets the static Subnet Mask.

*1. This key is for the firmware revision 1.0x

*2. This key is for the firmware revision 2.00 or later.

Parameter

	<String>
Preset value	"255.255.255.0"

Equivalent key

[System] - SYSTEM CONFIG - MANUAL SUBNET MASK - ENTER

:SYSTem:DATE

Syntax

:SYSTem:DATE <year>,<month>,<day>

:SYSTem:DATE?

Description

Sets the time in the internal clock.

Parameter

	<year>
Range	2000 to 2098
Unit	years
Resolution	1

	<month>
Range	1 to 12
Unit	months
Resolution	1

	<day>
Range	1 to 31
Unit	days
Resolution	1

Equivalent key

[System] - SYSTEM CONFIG - DATE/TIME - DATE - YEAR

[System] - SYSTEM CONFIG - DATE/TIME - DATE - MONTH

[System] - SYSTEM CONFIG - DATE/TIME - DATE - DAY

:SYSTem:ERRor[:NEXT]?

Syntax

:SYSTem:ERRor[:NEXT]?

Description

Returns an error message. (Query Only)

Equivalent key No equivalent key is available on the front panel.

:SYSTem:KLOCK

Syntax :SYSTem:KLOCK {ON|OFF|1|0}
:SYSTem:KLOCK?

Description Enables the front panel key lock. If the key lock's pin on the handle interface is set to "LOCK," touching the keys will have no effect.

Parameter

	Description
ON or 1	Enables the Front panel key lock
OFF or 0 (Preset value)	Disables the Front panel key lock

Equivalent key [Local/Lock]

:SYSTem:PRESet

Syntax :SYSTem:PRESet

Description Resets the instrument settings and correction data. (No Query)

Equivalent key [Preset] - CLEAR SET&CORR - OK

:SYSTem:REStart

Syntax :SYSTem:REStart

Description Reboots the instrument immediately. (No Query)

Equivalent key No equivalent key is available on the front panel.

:SYSTem:TIME

Syntax :SYSTem:TIME <hour>,<minute>,<second>
:SYSTem:TIME?

Description Sets the date in the internal clock.

Parameter

	<hour>
Range	0 to 23

	<hour>
Unit	hours
Resolution	1

	<minute>
Range	0 to 59
Unit	minutes
Resolution	1

	<second>
Range	0 to 59
Unit	seconds
Resolution	1

Equivalent key [System] - SYSTEM CONFIG - DATE/TIME - TIME - HOUR
 [System] - SYSTEM CONFIG - DATE/TIME - TIME - MINUTE
 [System] - SYSTEM CONFIG - DATE/TIME - TIME - SECOND

:SYSTem:TZONE

Syntax :SYSTem:TZONE <hour>[<minute>]
 :SYSTem:TZONE?

Description Configures the time zone. Sets the time difference from Greenwich mean time (GMT).

Parameter

	<hour>
Range	-12 to 15
Unit	hours
Resolution	1

	<minute>
Range	-45 to 45
Unit	minutes
Resolution	15

Equivalent key [System] - SYSTEM CONFIG - TIME ZONE

:TRIGger:DELay

Syntax :TRIGger:DELay <numeric>
:TRIGger:DELay?

Description Sets the step delay time.

Parameter

	<Numeric>
Range	0 to 999
Preset value	0
Unit	s
Resolution	100 μ

Equivalent key [Meas Setup] - MEAS SETUP - STEP DLY

:TRIGger[:IMMediate]

Syntax :TRIGger[:IMMediate]

Description Triggers the unit. (No Query)

Equivalent key [Trigger]

:TRIGger:SOURce

Syntax :TRIGger:SOURce {INTernal|HOLD|EXTernal|BUS}
:TRIGger:SOURce?

Description Selects the trigger mode.

Parameter

	Description
INTernal (Preset value)	Sets trigger source to “internal”
HOLD	Sets trigger source to “manual”
EXTernal	Sets trigger source to “external connector on the rear panel”
BUS	Sets trigger source to “GPIB/LAN/USB”

Equivalent key [Meas Setup] - MEAS SETUP - TRIG - INT

[Meas Setup] - MEAS SETUP - TRIG - MAN

[Meas Setup] - MEAS SETUP - TRIG - EXT

[Meas Setup] - MEAS SETUP - TRIG - BUS

:TRIGger:TDEL

Syntax :TRIGger:TDEL <numeric>
:TRIGger:TDEL?

Description Sets the trigger delay time.

Parameter

	<Numeric>
Range	0 to 999
Preset value	0
Unit	s
Resolution	100 μ

Equivalent key [Meas Setup] - TRIG SETUP - TRIG DLY

:VOLTage[:LEVel]

Syntax :VOLTage[:LEVel] <numeric>
:VOLTage[:LEVel]?

Description Sets the voltage level for the measurement signal. If the signal is set by :CURRent[:LEVel], the query command returns error No. 230.

Parameter

	<Numeric>
Range	0 to 20 ^{*1}
Preset value	1
Unit	V
Resolution	100 μ

*1. Depending on the DC bias level.

Equivalent key [Display Format] - MEAS DISPLAY - LEVEL
[Meas Setup] - MEAS SETUP - LEVEL

Command list

List by function

SCPI command list according to function

Function	Setting/execution item	Command
Abort	Abort trigger	:ABORt
Amplitude	ALC On/Off	:AMPLitude:ALC
Aperture	Integ time and averaging setup	:APERture
Comparator	Auxiliary BIN counting function On/Off	:COMParator:ABIN
	Beep Condition Selection	:COMParator:BEEPer
	Bin Limit value setting clear	:COMParator:BIN:CLEar
	BIN counts clear	:COMParator:BIN:COUNT:CLEar
	BIN count results readout	:COMParator:BIN:COUNT:DATA
	BIN count function On/Off	:COMParator:BIN:COUNT[:STATe]
	Limit mode setup	:COMParator:MODE
	Bin limit values setup for the sequential mode	:COMParator:SEQuence:BIN
	BIN Limit values setup for the secondary parameter	:COMParator:SLIMit
	Comparator function On/Off	:COMParator[:STATe]
	Swap parameter function On/Off	:COMParator:SWAP
	BIN limit values setup for the tolerance mode	:COMParator:TOLerance:BIN[1-9]
	Nominal value setup for the tolerance mode	:COMParator:TOLerance:NOMinal
Control	Current bias I/F enable	:CONTRol:CBias:STATe
	Handler I/F enable	:CONTRol:HANDler:STATe
	Scanner I/F enable	:CONTRol:SCANner:STATe

Function	Setting/execution item	Command
Correction	Cable length correction setup	:CORRection:LENGth
	LOAD correction On/Off	:CORRection:LOAD:STATe
	Measurement function selection for the load correction	:CORRection:LOAD:TYPE
	Correction mode selection	:CORRection:METhod
	OPEN correction execution	:CORRection:OPEN[:EXECute]
	OPEN correction On/Off	:CORRection:OPEN:STATe
	SHORT correction execution	:CORRection:SHORt[:EXECute]
	SHORT correction On/Off	:CORRection:SHORt:STATe
	Frequency setup for a specified measurement point	:CORRection:SPOT[1-201]:FREQuency
	LOAD execution at a specified measurement point	:CORRection:SPOT[1-201]:LOAD[:EXECute]
	LOAD reference values setup at a specified measurement point	:CORRection:SPOT[1-201]:LOAD:STANdard
	OPEN reference values setup at a specified measurement point	:CORRection:SPOT[1-201]:OPEN[:EXECute]
	SHORT reference values setup at a specified measurement point	:CORRection:SPOT[1-201]:SHORt[:EXECute]
	Specified measurement point enable	:CORRection:SPOT[1-201]:STATe
	Channel selection for MULTI mode	:CORRection:USE[:CHANnel]
	MULTI mode correction data readout	:CORRection:USE:DATA[:MULTi]
SINGLE mode correction data readout	:CORRection:USE:DATA:SINGLE	
Current	Current level setup	:CURRent[:LEVel]
Data buffer memory	Data buffer memory clear and disable	:MEMory:CLEAr
	Data buffer memory size setup	:MEMory:DIM
	Data buffer memory enable	:MEMory:FILL
	Data buffer memory readout	:MEMory:READ
DC bias	DC bias current setup	:BIAS:CURRent[:LEVel]
	Automatic Polarity Control On/Off	:BIAS:POLarity:AUTO
	Actual applied bias current output level readout	:BIAS:POLarity:CURRent[:LEVel]
	Actual applied bias voltage output level readout	:BIAS:POLarity:VOLTagE[:LEVel]
	DC Bias On/Off	:BIAS:STATe
	DC bias voltage setup	:BIAS:VOLTagE[:LEVel]
DC Output	DCI auto range enable	:OUTPut:DC:ISOLation:LEVel:AUTO
	DC isolation range selection	:OUTPut:DC:ISOLation:LEVel:VALue
	DC Isolation Enable	:OUTPut:DC:ISOLation[:STATe]
	Dummy command (for 4284A compatibility)	:OUTPut:HPOWer

SCPI Command Reference
Command list

Function	Setting/execution item	Command
DC Source	DC Source enable	:SOURce:DCSource:STATe
	DC source voltage setup	:SOURce:DCSource:VOLTage[:LEVel]
Display	Error or caution messages on display clear	:DISPlay:CClear
	Display update enable	:DISPlay:ENABle
	Comment line entry	:DISPlay:LINE
	Displayed page selection	:DISPlay:PAGE
	Most significant digit selection	:DISPlay[:WINDow]:TEXT[1-2][:DATA]:FMSD:DATA
	Fixed decimal point mode enable	:DISPlay[:WINDow]:TEXT[1-2][:DATA]:FMSD[:STATe]
Fetch	Complex measurement result readout	:FETCh[:IMPedance]:CORReCted
	Measurement result return with the selected measurement function	:FETCh[:IMPedance][:FORMatted]
	AC current monitor data readout	:FETCh:SMONitor:IAC
	DC current monitor data readout	:FETCh:SMONitor:IDC
	AC voltage monitor data readout	:FETCh:SMONitor:VAC
	DC voltage monitor data readout	:FETCh:SMONitor:VDC
Format	Long format enable	:FORMat:ASCIi:LONG
	Data transfer order selection in binary format	:FORMat:BORDer
	Data transfer format selection	:FORMat[:DATA]
Frequency	Frequency setup	:FREQuency[:CW]
Function	DCR measurement auto range function enable	:FUNCTion:DCResistance:RANGe:AUTO
	DCR measurement range selection	:FUNCTion:DCResistance:RANGe[:VALue]
	Deviation measurement mode selection	:FUNCTion:DEV[1-2]:MODE
	Measurement execution for reference values of the deviation measurement	:FUNCTion:DEV[1-2]:REFerence:FILL
	Reference value setup for deviation measurement	:FUNCTion:DEV[1-2]:REFerence[:VALue]
	Impedance measurement auto range enable	:FUNCTion:IMPedance:RANGe:AUTO
	Impedance measurement range selection	:FUNCTion:IMPedance:RANGe[:VALue]
	Measurement function selection	:FUNCTion:IMPedance[:TYPE]
	Dummy command (for 4284A compatibility)	:FUNCTion:SMONitor:IAC[:STATe]
	DC current level monitor enable	:FUNCTion:SMONitor:IDC[:STATe]
	Dummy command (for 4284A compatibility)	:FUNCTion:SMONitor:VAC[:STATe]
	DC voltage level monitor enable	:FUNCTion:SMONitor:VDC[:STATe]
Hcopy	Screen image output to the controller	:HCOPY:SDUMp:DATA

Function	Setting/execution item	Command
IEEE	Error queue and register clear	*CLS
	Standard Event Status Enable Register setup	*ESE
	Standard Event Status Register readout	*ESR
	Product information readout	*IDN
	Setup record and play	*LRN
	Operation completes readout	*OPC
	Installed option numbers readout	*OPT
	Instrument setting reset	*RST
	Service Request Enable register setup	*SRE
	Status Byte register readout	*STB
	Trigger	*TRG
	Dummy command (for 4284A compatibility)	*TST
	Waits	*WAI
Initiate	Auto trigger state initiate enable	:INITiate:CONTinuous
	WAIT FOR TRIGGER initiate	:INITiate[:IMMediate]
List Sweep	Limit value setup for the list sweep measurement.	:LIST:BAND[1-201]
	DC current list sweep setup	:LIST:BIAS:CURRent
	DC voltage list sweep setup	:LIST:BIAS:VOLTagE
	List sweep setup clear	:LIST:CLear:ALL
	AC current list sweep setup	:LIST:CURRent
	DC source list sweep setup	:LIST:DCSource:VOLTagE
	Frequency list sweep setup	:LIST:FREQuency
	Sweep mode selection for list sweep	:LIST:MODE
	Time stamp clear of the executed list sweep	:LIST:SEQuence:TSTamp:CLear
	Time stamp readout of the list sweep	:LIST:SEQuence:TSTamp:DATA
	List sweep setup parameter	:LIST:STIMulus:DATA
	Actual stimulus values readout for list sweep parameter	:LIST:STIMulus:MDATA
	Parameter types selection for list sweep parameter	:LIST:STIMulus:TYPE
	AC voltage list sweep setup	:LIST:VOLTagE
Save/Recall	State delete from the memories	:MMEMory:DELEte[:REGister]
	State Load from the memories	:MMEMory:LOAD:STATe[:REGister]
	State Store to the memories	:MMEMory:STORe:STATe[:REGister]

SCPI Command Reference
Command list

Function	Setting/execution item	Command
Status register	Operation Status Condition register readout	:STaTus:OPERation:CONDition
	Operation Status Enable register setup	:STaTus:OPERation:ENABle
	Operation Status Event register return	:STaTus:OPERation[:EVENT]
System	Beeps	:SYSTem:BEEPer[:IMMediate]
	Beep sound enable	:SYSTem:BEEPer:STATe
	Beep sound tone selection	:SYSTem:BEEPer:TONE
	GPIB address setup	:SYSTem:COMMunicate:GPIB[:SELF]:ADDReSS
	Static IP address setup	:SYSTem:COMMunicate:LAN[:SELF]:ADDReSS
	IP address obtaining method	:SYSTem:COMMunicate:LAN[:SELF]:CONFIgure
	SOCKET control port number readout	:SYSTem:COMMunicate:LAN[:SELF]:CONTRol
	Current IP address readout	:SYSTem:COMMunicate:LAN[:SELF]:CURRent:ADDReSS
	Current Gateway address readout	:SYSTem:COMMunicate:LAN[:SELF]:CURRent:DGATeWay
	Current Subnet Mask readout	:SYSTem:COMMunicate:LAN[:SELF]:CURRent:SMASK
	Static Gateway address setup	:SYSTem:COMMunicate:LAN[:SELF]:DGATeWay
	MAC address readout	:SYSTem:COMMunicate:LAN[:SELF]:MAC
	Network preset	:SYSTem:COMMunicate:LAN[:SELF]:PRESet
	Network restart	:SYSTem:COMMunicate:LAN[:SELF]:REStart
	Static Subnet Mask setup	:SYSTem:COMMunicate:LAN[:SELF]:SMASK
	Clock time setup	:SYSTem:DATE
	Error message readout	:SYSTem:ERRor[:NEXT]
	Front panel key lock enable	:SYSTem:KLOCK
	Instrument setting and correction data reset	:SYSTem:PRESet
	Reboot the instrument immediately	:SYSTem:REStart
	Clock date setup	:SYSTem:TIME
	Time zone setup	:SYSTem:TZONE
Trigger	Step delay time setup	:TRIGger:DELay
	Trigger	:TRIGger[:IMMediate]
	Selects the trigger mode	:TRIGger:SOURce
	Trigger delay time setup	:TRIGger:TDEL
Voltage	Voltage level setup	:VOLTage[:LEVeL]

Command Tree

Command	Parameter	Note
*CLS		[No Query]
*ESE	< numeric>	
*ESR	< numeric>	[Query only]
*IDN	< string>	[Query only]
*LRN	< string>	[Query only]
*OPC		[No Query]
*OPT	< string>	[Query only]
*RST		[No Query]
*SRE	< numeric>	
*STB	< numeric>	[Query only]
*TRG		[No Query]
*TST	< numeric>	[Query only]
*WAI		[No Query]
:ABORt		[No Query]
:AMPLitude		
:ALC	{ON OFF 1 0}	
:APERture	{SHORt MEDIum LONG },< numeric>	
:BIAS		
:CURRent		
[:LEVel]	< numeric>	
:POLarity		
:AUTO	{ON OFF 1 0}	
:CURRent		
[:LEVel]	< numeric>	[Query only]
:VOLTage		
[:LEVel]	< numeric>	[Query only]
:STATe	{ON OFF 1 0}	
:VOLTage		
[:LEVel]	< numeric>	
:COMParator		
:ABIN	{ON OFF 1 0}	
:BEEPer	{FAIL PASS}	

SCPI Command Reference
Command list

Command	Parameter	Note
:BIN		
:CLEar		[No Query]
:COUNt		
:CLEar		[No Query]
:DATA	< numeric>,< numeric>,< numeric>,< numeric>,< numeric>,< numeric>,< numeric>,< numeric>,< numeric>,< numeric>	[Query only]
:STATe	{ON OFF 1 0}	
:MODE	{ATOLerance PTOLerance SEQuence}	
:SEQuence		
:BIN	< array>	
:SLIMit	< numeric>,< numeric>	
:STATe	{ON OFF 1 0}	
:SWAP	{ON OFF 1 0}	
:TOLerance		
:BIN[1-9]	< numeric>,< numeric>	
:NOMinal	< numeric>	
:CONTRol		
:CBIas		
:STATe	{ON OFF 1 0}	
:HANDler		
:STATe	{ON OFF 1 0}	
:SCANner		
:STATe	{ON OFF 1 0}	
:CORRection		
:LENGth	< numeric>	
:LOAD		
:STATe	{ON OFF 1 0}	
:TYPE	{CPD CPQ CPG CPRP CSD CSQ C SRS LPD LPQ LPG LPRP LSD LS Q LSRS RX ZTD ZTR GB YTD YTR}	
:METHod	{SINGle MULtiple}	
:OPEN		
:EXECute		[No Query]

Command	Parameter	Note
:STATe	{ON OFF 1 0}	
:SHORt		
[:EXECute]		[No Query]
:STATe	{ON OFF 1 0}	
:SPOT[1-201]		
:FREQuency	< numeric>	
:LOAD		
[:EXECute]		[No Query]
:STANdard	< numeric>,< numeric>	
:OPEN		
[:EXECute]		[No Query]
:SHORt		
[:EXECute]		[No Query]
:STATe	{ON OFF 1 0}	
:USE		
[:CHANnel]	< numeric>	
:DATA		
[:MULTi]	< numeric>,< array>	
:SINGle	< array>	
:CURRent		
[:LEVel]	< numeric>	
:DISPlay		
:CClear		[No Query]
:ENABle	{ON OFF 1 0}	
:LINE	< string>	
:PAGE	{MEASurement BNUMBER BCOunt LIST MSETup CSETup LTABLE LS ETup CATAlog SYSTem SELF ML ARge SCONfig SERVice}	
[:WINDow]		
:TEXT[1-2]		
[:DATA]		
:FMSD		
:DATA	< numeric>	
[:STATe]	{ON OFF 1 0}	

SCPI Command Reference
Command list

Command	Parameter	Note
:FETCh		
[:IMPedance]		
:CORReCted	< numeric>,< numeric>	[Query only]
[:FORMatted]	< numeric>,< numeric>,< numeric>	[Query only]
:SMONitor		
:IAC	< numeric>	[Query only]
:IDC	< numeric>	[Query only]
:VAC	< numeric>	[Query only]
:VDC	< numeric>	[Query only]
:FORMat		
:ASCIi		
:LONG	{ON OFF 1 0}	
:BORDER	{NORMAl SWAPped}	
[:DATA]	{ASCIi REAL },< numeric>	
:FREQuency		
[:CW]	< numeric>	
:FUNction		
:DCResistance		
:RANGe		
:AUTO	{ON OFF 1 0}	
[:VALue]	< numeric>	
:DEV[1-2]		
:MODE	{ABSolute PERCent OFF}	
:REFerence		
:FILL		[No Query]
[:VALue]	< numeric>	
:IMPedance		
:RANGe		
:AUTO	{ON OFF 1 0}	
[:VALue]	< numeric>	
[:TYPE]	{CPD CPQ CPG CPRP CSD CSQ CSRS LPD LPQ LPG LPRP LPRD LSD LSQ LSRS LSRD RX ZTD ZTR GB YTD YTR VDID}	
:SMONitor		

Command	Parameter	Note
:IAC		
[:STATe]	{ON OFF 1 0}	
:IDC		
[:STATe]	{ON OFF 1 0}	
:VAC		
[:STATe]	{ON OFF 1 0}	
:VDC		
[:STATe]	{ON OFF 1 0}	
:HCOpy		
:SDUMp		
:DATA	< block>	[Query only]
:INITiate		
:CONTinuous	{ON OFF 1 0}	
[:IMMediate]		[No Query]
:LIST		
:BAND[1-201]	{A B OFF },< numeric>,< numeric>	
:BIAS		
:CURRent	< array>	
:VOLTagE	< array>	
:CLEar		
:ALL		[No Query]
:CURRent	< array>	
:DCSource		
:VOLTagE	< array>	
:FREQuency	< array>	
:MODE	{SEQuence STEPped}	
:SEQuence		
:TSTamp		
:CLEar		[No Query]
:DATA	< array>	[Query only]
:STIMulus		
:DATA	< array>	
:MDATA	< array>	[Query only]

SCPI Command Reference
Command list

Command	Parameter	Note
:TYPE	{FREQuency VOLTage CURRent B VOLTage BCURrent DCSVoltage , {NONE IRANge FREQuency VO LTage CURRent BVOLTage BCURr ent DCSVoltage}	
:VOLTage	< array>	
:MEMory		
:CLEar	{DBUF}	[No Query]
:DIM	{DBUF },< numeric>	
:FILL	{DBUF}	[No Query]
:READ	{DBUF },< block>	[Query only]
:MMEMory		
:DELete		
[:REGister]	< numeric>	[No Query]
:LOAD		
:STATe		
[:REGister]	< numeric>	[No Query]
:STORe		
:STATe		
[:REGister]	< numeric>	[No Query]
:OUTPut		
:DC		
:ISOLation		
:LEVel		
:AUTO	{ON OFF 1 0}	
:VALue	< numeric>	
[:STATe]	{ON OFF 1 0}	
:HPOWer	{ON OFF 1 0}	
:SOURce		
:DcSource		
:STATe	{ON OFF 1 0}	
:VOLTage		
[:LEVel]	< numeric>	
:STATus		
:OPERation		
:CONDition	< numeric>	[Query only]

Command	Parameter	Note
:ENABLE	< numeric>	
[:EVENT]	< numeric>	[Query only]
:SYSTEM		
:BEEPer		
[:IMMediate]		[No Query]
:STATe	{ ON OFF 1 0 }	
:TONE	< numeric>	
:COMMunicate		
:GPIB		
[:SELF]		
:ADDRes	< numeric>	
:LAN		
[:SELF]		
:ADDRes	< string>	
:CONFigre	{ AUTO MANual }	
:CONTRol	< numeric>	[Query only]
:CURRent		
:ADDRes	< string>	[Query only]
:DGAteWay	< string>	[Query only]
:SMASk	< string>	[Query only]
:DGAteWay	< string>	
:MAC	< string>	[Query only]
:REStart		[No Query]
:REStart		[No Query]
:SMASk	< string>	
:DATE	< numeric>,< numeric>,< numeric>	
:ERRor		
[:NEXT]	< numeric>,< string>	[Query only]
:KLOCK	{ ON OFF 1 0 }	
:PRESet		[No Query]
:REStart		[No Query]
:TIME	< numeric>,< numeric>,< numeric>	
:TZONe	< numeric>[,< numeric>]	
:TRIGger		

SCPI Command Reference
Command list

Command	Parameter	Note
:DELay	< numeric>	
[:IMMediate]		[No Query]
:SOURce	{INTernal HOLD EXTernal BUS}	
:TDEL	< numeric>	
:VOLTage		
[:LEVel]	< numeric>	

Softkey Functions

Key Operation	Function	SCPI Command
[DC Bias]	Turns ON/OFF DC bias	:BIAS:STAT
[DC Source]	Turns ON/OFF DC Source	:SOUR:DCS:STAT
[Display Format]		
BIN COUNT		
COUNT		
COUNT OFF	Turns ON/OFF the BIN count function	:COMP:BIN:COUN:STAT OFF
COUNT ON	Turns ON/OFF the BIN count function	:COMP:BIN:COUN:STAT ON
RESET COUNT	Clears all BIN counts	:COMP:BIN:COUN:CLE
BIN No.		
COMP		
OFF	Turns OFF the comparator function	COMP:STAT OFF
ON	Turns ON the comparator function	COMP:STAT ON
DISPLAY BLANK	Enables display update	:DISP:ENAB
LIST SWEEP		
DISPLAY BLANK	Enables display update	:DISP:ENAB
LIST TABLE		
NEXT PAGE	Displays next page	
PREV PAGE	Displays previous page	
MODE		
SEQ	Selects the sweep mode for the list sweep measurement function	:LIST:MODE SEQ
STEP	Selects the sweep mode for the list sweep measurement function	:LIST:MODE STEP
MEAS DISPLAY		
BIAS	Sets the DC bias	:BIAS:VOLT:LEV :BIAS:CURR:LEV
DISPLAY BLANK	Enables display update	:DISP:ENAB
Fixed Decimal Point Menu		
D.P. AUTO	Enables the fixed decimal point mode	:DISP:WIND:TEXT[1-2]:DATA: FMSD:STAT
D.P. FIX	Enables the fixed decimal point mode	:DISP:WIND:TEXT[1-2]:DATA: FMSD:STAT
D.P. POS DECL -	Selects the most significant digit at the fixed decimal point mode	:DISP:WIND:TEXT[1-2]:DATA: FMSD:DATA

SCPI Command Reference
Command list

Key Operation	Function	SCPI Command
D.P.POSINCR +	Selects the most significant digit at the fixed decimal point mode	:DISP:WIND:TEXT[1-2]:DATA: FMSD:DATA
FREQ	Sets the measurement frequency	:FREQ: CW
FUNC		
Cp- ...		
Cp-D	Selects the measurement function	:FUNC:IMP:TYPE CPD
Cp-G	Selects the measurement function	:FUNC:IMP:TYPE CPG
Cp-Q	Selects the measurement function	:FUNC:IMP:TYPE CPQ
Cp-Rp	Selects the measurement function	:FUNC:IMP:TYPE CPRP
RETURN	Returns to the softkey display screen one level higher	
Cs- ...		
Cs-D	Selects the measurement function	:FUNC:IMP:TYPE CSD
Cs-Q	Selects the measurement function	:FUNC:IMP:TYPE CSQ
Cs-Rs	Selects the measurement function	:FUNC:IMP:TYPE CSRS
RETURN	Returns to the softkey display screen one level higher	
Lp- ...		
Lp-D	Selects the measurement function	:FUNC:IMP:TYPE LPD
Lp-G	Selects the measurement function	:FUNC:IMP:TYPE LPG
Lp-Q	Selects the measurement function	:FUNC:IMP:TYPE LPQ
Lp-Rdc	Selects the measurement function	:FUNC:IMP:TYPE LPRD
Lp-Rp	Selects the measurement function	:FUNC:IMP:TYPE LPRP
RETURN	Returns to the softkey display screen one level higher	
Ls- ...		
Ls-D	Selects the measurement function	:FUNC:IMP:TYPE LSD
Ls-Q	Selects the measurement function	:FUNC:IMP:TYPE LSQ
Ls-Rdc	Selects the measurement function	:FUNC:IMP:TYPE LSRD
Ls-Rs	Selects the measurement function	:FUNC:IMP:TYPE LSRS
RETURN	Returns to the softkey display screen one level higher	
MORE		
G-B	Selects the measurement function	:FUNC:IMP:TYPE GB
R-X	Selects the measurement function	:FUNC:IMP:TYPE RX
Vdc-Idc	Selects the measurement function	:FUNC:IMP:TYPE VDIM
Y- ...		
Y-0d	Selects the measurement function	:FUNC:IMP:TYPE YTD

Key Operation	Function	SCPI Command
Y- θ r	Selects the measurement function	:FUNC:IMP:TYPE YTR
RETURN	Returns to the softkey display screen one level higher	
Z- ...		
Z- θ d	Selects the measurement function	:FUNC:IMP:TYPE ZTD
Z- θ r	Selects the measurement function	:FUNC:IMP:TYPE ZTR
RETURN	Returns to the softkey display screen one level higher	
LEVEL	Returns the actual applied bias output level	:VOLT:LEV :CURR:LEV
MEAS TIME		
LONG	Sets the integration time and the averaging rate	:APER LONG
MED	Sets the integration time and the averaging rate	:APER MED
SHORT	Sets the integration time and the averaging rate	:APER SHOR
RANGE	Selects impedance measurement range	:FUNC:IMP:RANG:VAL
AUTO	Enables the auto range function for the impedance measurement	:FUNC:IMP:RANG:AUTO ON
HOLD	Enables the auto range function for the impedance measurement	:FUNC:IMP:RANG:AUTO OFF
[Local/Lock]	Enables the front panel key lock	:SYST:KLOC
[Meas Setup]		
CORRECTION		
CABLE		
0 m	Selects the cable length correction setting	:CORR:LENG 0
1 m	Selects the cable length correction setting	:CORR:LENG 1
2 m	Selects the cable length correction setting	:CORR:LENG 2
4 m	Selects the cable length correction setting	:CORR:LENG 4
CH	Selects the channel number to be used for MULTI mode	:CORR:USE:CHAN
FREQ	Sets the frequency for the specified measurement point	CORR:SPOT[1-201]:FREQ
MEAS LOAD	Executes the LOAD correction at the specified measurement point	:CORR:SPOT[1-201]:LOAD:EXEC
MEAS OPEN	Executes the OPEN correction at the specified measurement point	:CORR:SPOT[1-201]:OPEN:EXEC
MEAS SHORT	Executes the SHORT correction at the specified measurement point	:CORR:SPOT[1-201]:SHOR:EXEC
OFF	Enables the specified measurement point	:CORR:SPOT[1-201]:STAT OFF
ON	Enables the specified measurement point	:CORR:SPOT[1-201]:STAT ON
FUNC		
Cp- ...		

SCPI Command Reference
Command list

Key Operation	Function	SCPI Command
Cp-D	Selects the measurement function of the reference values for the LOAD correction	:CORR:LOAD:TYPE CPD
Cp-G	Selects the measurement function of the reference values for the LOAD correction	:CORR:LOAD:TYPE CPG
Cp-Q	Selects the measurement function of the reference values for the LOAD correction	:CORR:LOAD:TYPE CPQ
Cp-Rp	Selects the measurement function of the reference values for the LOAD correction	:CORR:LOAD:TYPE CPRP
RETURN	Returns to the softkey display screen one level higher	
Cs- ...		
Cs-D	Selects the measurement function of the reference values for the LOAD correction	:CORR:LOAD:TYPE CSD
Cs-Q	Selects the measurement function of the reference values for the LOAD correction	:CORR:LOAD:TYPE CSQ
Cs-Rs	Selects the measurement function of the reference values for the LOAD correction	:CORR:LOAD:TYPE CSRS
RETURN	Returns to the softkey display screen one level higher	
Lp- ...		
Lp-D	Selects the measurement function of the reference values for the LOAD correction	:CORR:LOAD:TYPE LPD
Lp-G	Selects the measurement function of the reference values for the LOAD correction	:CORR:LOAD:TYPE LPG
Lp-Q	Selects the measurement function of the reference values for the LOAD correction	:CORR:LOAD:TYPE LPQ
Lp-Rp	Selects the measurement function of the reference values for the LOAD correction	:CORR:LOAD:TYPE LPRP
RETURN	Returns to the softkey display screen one level higher	
Ls- ...		
Ls-D	Selects the measurement function of the reference values for the LOAD correction	:CORR:LOAD:TYPE LSD
Ls-Q	Selects the measurement function of the reference values for the LOAD correction	:CORR:LOAD:TYPE LSQ
Ls-Rs	Selects the measurement function of the reference values for the load correction	:CORR:LOAD:TYPE LSRS
RETURN	Returns to the softkey display screen one level higher	
MORE		
G-B	Selects the measurement function of the reference values for the LOAD correction	:CORR:LOAD:TYPE GB
RETURN	Returns to the softkey display screen one level higher	
R-X	Selects the measurement function of the reference values for the LOAD correction	:CORR:LOAD:TYPE RX

Key Operation	Function	SCPI Command
Y- ...		
Y- θ d	Selects the measurement function of the reference values for the LOAD correction	:CORR:LOAD:TYPE YTD
Y- θ r	Selects the measurement function of the reference values for the LOAD correction	:CORR:LOAD:TYPE YTR
Z- ...		
Z- θ d	Selects the measurement function of the reference values for the LOAD correction	:CORR:LOAD:TYPE ZTD
Z- θ r	Selects the measurement function of the reference values for the LOAD correction	:CORR:LOAD:TYPE ZTR
LOAD		
OFF	Turns OFF the LOAD correction	:CORR:LOAD:STAT OFF
ON	Turns ON the LOAD correction	:CORR:LOAD:STAT ON
LOAD A	Executes the LOAD correction at the specified measurement point	:CORR:SPOT[1-201]:LOAD:STAN
LOAD B	Executes the LOAD correction at the specified measurement point	:CORR:SPOT[1-201]:LOAD:STAN
MODE		
MULTI	Selects the correction mode	:CORR:METH MULT
SINGLE	Selects the correction mode	:CORR:METH SING
OPEN		
MEAS OPEN	Executes the OPEN correction	CORR:OPEN:EXEC
ABORT	Resets the trigger system, putting the trigger state in the IDLE STATE on the state diagram	:ABOR
OFF	Turns OFF the OPEN correction	CORR:OPEN:STAT OFF
ON	Turns ON the OPEN correction	CORR:OPEN:STAT ON
OPEN A	Executes the OPEN correction at the specified measurement point	:CORR:SPOT[1-201]:OPEN:SEL
OPEN B	Executes the OPEN correction at the specified measurement point	:CORR:SPOT[1-201]:OPEN:SEL
REF A	Sets the reference values of the standard at the specified measurement point	:CORR:SPOT[1-201]:LOAD:STAN
REF B	Sets the reference values of the standard at the specified measurement point	:CORR:SPOT[1-201]:LOAD:STAN
SHORT		
MEAS SHORT		
ABORT	Resets the trigger system, putting the trigger state in the IDLE STATE on the state diagram	:ABOR
OFF	Turns OFF the SHORT correction	CORR:SHOR:STAT OFF
ON	Turns ON the SHORT correction	CORR:SHOR:STAT ON

SCPI Command Reference
Command list

Key Operation	Function	SCPI Command
SHORT A	Executes the SHORT correction at the specified measurement point	:CORR:SPOT[1-201]:SHOR:SEL
SHORT B	Executes the SHORT correction at the specified measurement point	:CORR:SPOT[1-201]:SHOR:SEL
SPOT No.	Selects the cable length correction setting	
LIMIT TABLE		
AUX		
OFF	Turns OFF the auxiliary BIN counting function	:COMP:ABIN OFF
ON	Turns ON the auxiliary BIN counting function	:COMP:ABIN ON
BEEP		
FAIL	Selects the condition for generating a beep sound	:COMP:BEEP FAIL
PASS	Selects the condition for generating a beep sound	:COMP:BEEP PASS
BIN		
CLEAR TABLE	Clears the list sweep setup	:LIST:CLE:ALL
COMP		
OFF	Turns OFF the comparator function	:COMP:STAT OFF
ON	Turns ON the comparator function	:COMP:STAT ON
FUNC		
SWAP PARAM	Turns ON/OFF the swap parameter function	:COMP:SWAP
High		
CLEAR	Clears the high limit values for the comparator function	
CLEAR LINE	Sets the lower/upper limit values of each BIN for the comparator function tolerance mode	
LOW x(-1)	Sets the upper limit values for the comparator function secondary parameter	:COMP:SLIM
LOW		
CLEAR	Clears the lower limit values for the comparator function	
CLEAR LINE	Sets the lower/upper limit values of each BIN for the comparator function tolerance mode	
HIGH x(-1)	Sets the lower limit values for the comparator function secondary parameter	:COMP:SLIM
MODE		
%	Selects the limit mode of the comparator function	:COMP:MODE PTOL
ABS	Selects the limit mode of the comparator function	:COMP:MODE ATOL
SEQ	Selects the limit mode of the comparator function	:COMP:MODE SEQ
NOM	Sets the nominal value for the tolerance mode of the comparator function	:COMP:TOL:NOM
LIST SETUP		

Key Operation	Function	SCPI Command
FREQ[Hz]		
FREQ [Hz]	Clears the previous list sweep table, sets frequency sweep as the list sweep parameter, and sets frequency points for the frequency list sweep	:LIST:FREQ
LEVEL [A]	Clears the previous list sweep table, sets AC current sweep as the list sweep parameter, and sets AC current points for the AC current list sweep	:LIST:CURR
LEVEL [V]	Clears the previous list sweep table, sets AC current sweep as the list sweep parameter, and sets AC current points for the AC current list sweep	:LIST:VOLT
MORE		
BIAS [A]	Clears the previous list sweep table, sets DC current sweep as the list sweep parameter, and sets DC current points for the DC current list sweep	:LIST:BIAS:CURR
BIAS [V]	Clears the previous list sweep table, sets DC current sweep as the list sweep parameter, and sets DC current points for the DC current list sweep	:LIST:BIAS:VOLT
DC SRC [V]	Clears the previous list sweep table, sets the DC source sweep as the list sweep parameter, and sets DC source points for the DC source list sweep	:LIST:DCS:VOLT
RETURN	Returns to the softkey display screen one level higher	
FREQ[Hz]^{*1}		
CLEAR LINE	Clears the sweep point that has been selected	
FILL LINEAR	Fill the sweep points between selected two points with linear	
FILL LOG	Fill the sweep points between selected two points with log	
NEXT PAGE	Displays the next page	
PREV PAGE	Displays the previous page	
HIGH		
CLEAR LINE	Clears the sweep point that has been selected	
NEXT PAGE	Displays the next page	
PREV PAGE	Displays the previous page	
LMT		
-	Sets the limit values of the limit function for the list sweep measurement	:LIST:BAND OFF
A	Sets the limit values of the limit function for the list sweep measurement	:LIST:BAND A
B	Sets the limit values of the limit function for the list sweep measurement	:LIST:BAND B
LOW		
CLEAR LINE		
NEXT PAGE	Displays the next page	
PREV PAGE	Displays the previous page	
MODE		

SCPI Command Reference
Command list

Key Operation	Function	SCPI Command
SEQ	Selects the sweep mode for the list sweep measurement function	:LIST:MODE SEQ
STEP	Selects the sweep mode for the list sweep measurement function	:LIST:MODE STEP
No.		
CLEAR TABLE	Clears the list sweep setup	:LIST:CLE:ALL
NEXT PAGE	Displays the next page	
PREV PAGE	Displays the previous page	
MEAS SETUP		
ALC		
OFF	Turns OFF the Automatic Level Control (ALC)	:AMPL:ALC OFF
ON	Turns ON the Automatic Level Control (ALC)	:AMPL:ALC ON
AVG	Sets the integration time and the averaging rate	:APER
BIAS	Sets the DC bias.	:BIAS:VOLT:LEV :BIAS:CURR:LEV
BIAS POL		
AUTO	Turns ON the Automatic Polarity Control	:BIAS:POL:AUTO ON
FIX	Turns OFF the Automatic Polarity Control	:BIAS:POL:AUTO OFF
DC SRC	Sets the voltage level of DC source	:SOUR:DCS:VOLT:LEV
DCI ISO	Sets the DC Isolation	:OUTP:DC:ISOL:LEV:VAL
OFF	Disables DC Isolation	:OUTP:DC:ISOL:STAT OFF
ON	Enables DC Isolation	:OUTP:DC:ISOL:STAT ON
DCI RNG	Selects DCI range	:OUTP:DC:ISOL:LEV:VAL
AUTO	Enables the auto range function for DCI	:OUTP:DC:ISOL:LEV:AUTO ON
HOLD	Disables the auto range function for DCI	:OUTP:DC:ISOL:LEV:AUTO OFF
DCR RNG	Selects DCR measurement range	:FUNC:DCR:RANG:VAL
AUTO	Enables the auto range function for the DCR measurement	:FUNC:DCR:RANG:AUTO ON
HOLD	Disables the auto range function for the DCR measurement	:FUNC:DCR:RANG:AUTO OFF
DEV A		
%	Selects the deviation measurement mode	:FUNC:DEV1:MODE PERC
ABS	Selects the deviation measurement mode	:FUNC:DEV1:MODE ABS
OFF	Selects the deviation measurement mode	:FUNC:DEV1:MODE OFF
DEV B		
%	Selects the deviation measurement mode	:FUNC:DEV2:MODE PERC

Key Operation	Function	SCPI Command
ABS	Selects the deviation measurement mode	:FUNC:DEV2:MODE ABS
OFF	Selects the deviation measurement mode	:FUNC:DEV2:MODE OFF
FREQ	Sets the measurement frequency	:FREQ:CW
%	Selects the deviation measurement mode	:FUNC:DEV1:MODE PERC
ABS	Selects the deviation measurement mode	:FUNC:DEV1:MODE ABS
OFF	Selects the deviation measurement mode	:FUNC:DEV1:MODE OFF
FUNC		
Cp- ...		
Cp-D	Selects the measurement function	:FUNC:IMP:TYPE CPD
Cp-G	Selects the measurement function	:FUNC:IMP:TYPE CPG
Cp-Q	Selects the measurement function	:FUNC:IMP:TYPE CPQ
Cp-Rp	Selects the measurement function	:FUNC:IMP:TYPE CPRP
RETURN	Returns to the softkey display screen one level higher	
Cs- ...		
Cs-D	Selects the measurement function	:FUNC:IMP:TYPE CSD
Cs-Q	Selects the measurement function	:FUNC:IMP:TYPE CSQ
Cs-Rs	Selects the measurement function	:FUNC:IMP:TYPE CSRS
RETURN	Returns to the softkey display screen one level higher	
Lp- ...		
Lp-D	Selects the measurement function	:FUNC:IMP:TYPE LPD
Lp-G	Selects the measurement function	:FUNC:IMP:TYPE LPG
Lp-Q	Selects the measurement function	:FUNC:IMP:TYPE LPQ
Lp-Rdc	Selects the measurement function	:FUNC:IMP:TYPE LPRD
Lp-Rp	Selects the measurement function	:FUNC:IMP:TYPE LPRP
RETURN	Returns to the softkey display screen one level higher	
Ls- ...		
Ls-D	Selects the measurement function	:FUNC:IMP:TYPE LSD
Ls-Q	Selects the measurement function	:FUNC:IMP:TYPE LSQ
Ls-Rdc	Selects the measurement function	:FUNC:IMP:TYPE LSRD
Ls-Rs	Selects the measurement function	:FUNC:IMP:TYPE LSRS
RETURN	Returns to the softkey display screen one level higher	
MORE		
G-B	Selects the measurement function	:FUNC:IMP:TYPE GB
R-X	Selects the measurement function	:FUNC:IMP:TYPE RX

SCPI Command Reference
Command list

Key Operation	Function	SCPI Command
Vdc-Idc	Selects the measurement function	:FUNC:IMP:TYPE VDID
Y- ...		
Y-θd	Selects the measurement function	:FUNC:IMP:TYPE YTD
Y-θr	Selects the measurement function	:FUNC:IMP:TYPE YTR
RETURN	Returns to the softkey display screen one level higher	
Z- ...		
Z-θd	Selects the measurement function	:FUNC:IMP:TYPE ZTD
Z-θr	Selects the measurement function	:FUNC:IMP:TYPE ZTR
RETURN	Returns to the softkey display screen one level higher	
RETURN	Returns to the softkey display screen one level higher	
IDC MON		
OFF	Disables the DC current level monitor function	:FUNC:SMON:IDC:STAT OFF
ON	Enables the DC current level monitor function	:FUNC:SMON:IDC:STAT ON
LEVEL	Sets the voltage level for the measurement signal	:VOLT:LEV :CURR:LEV
MEAS TIME		
LONG	Sets the integration time and the averaging rate	:APER LONG
MED	Sets the integration time and the averaging rate	:APER MED
SHORT	Sets the integration time and the averaging rate	:APER SHOR
RANGE	Selects impedance measurement range	:FUNC:IMP:RANG:VAL
AUTO	Enables the auto range function for the impedance measurement	:FUNC:IMP:RANG:AUTO ON
HOLD	Enables the auto range function for the impedance measurement	:FUNC:IMP:RANG:AUTO OFF
REF A	Sets the reference value for deviation measurement	:FUNC:DEV1:REF:VAL
MEAS ABORT	Resets the trigger system, putting the trigger in the IDLE STATE on the state diagram	
MEASURE	Executes a single measurement and enters two measured values into each of the reference values for the deviation measurement	:FUNC:DEV1:REF:FILL
REF B	Sets the reference value for deviation measurement	:FUNC:DEV2:REF:VAL
MEAS ABORT	Resets the trigger system, putting the trigger in the IDLE STATE on the state diagram	
MEASURE	Executes a single measurement and enters two measured values into each of the reference values for the deviation measurement	:FUNC:DEV2:REF:FILL
STEP DLY	Sets the step delay time	:TRIG:DEL
TRIG		
BUS	Selects the trigger mode	:TRIG:SOUR BUS

Key Operation	Function	SCPI Command
EXT	Selects the trigger mode	:TRIG:SOUR EXT
INT	Selects the trigger mode	:TRIG:SOUR INT
MAN	Selects the trigger mode	:TRIG:SOUR HOLD
TRIG DLY	Sets the trigger delay time	:TRIG:TDEL
USER COMMENT*2		
ADD CHAR	Inputs the comments	
ENTER	Enters arbitrary comments into the comment line	:DISP:LINE
NEXT	Displays the next page	
PREV	Displays the previous page	
VDC MON		
OFF	Disables the DC voltage level monitor function	:FUNC:SMON:VDC:STAT OFF
ON	Enables the DC voltage level monitor function	:FUNC:SMON:VDC:STAT ON
[Preset]		
CLEAR SET&CORR		
CANCEL	Returns to the softkey display screen one level higher	
OK	Resets the instrument setting and correction data	:SYST:PRES
RETURN	Returns to the softkey display screen one level higher	
CLEAR SETTING		
CANCEL	Returns to the softkey display screen one level higher	
OK	Resets the instrument settings	*RST
RETURN	Returns to the softkey display screen one level higher	
FACTORY DEFAULT		
CANCEL	Returns to the softkey display screen one level higher	
OK	Reverts to factory default settings with all user-configurable data cleared.	
RETURN	Returns to the softkey display screen one level higher	
LAN RESET		
CANCEL	Returns to the softkey display screen one level higher	
OK	Resets the LAN settings.	:SYST:COMM:LAN:PRES
RETURN	Returns to the softkey display screen one level higher	
[Recall A]	Loads the state 0 from the memories	:MMEM:LOAD:STAT:REG 0
[Recall B]	Loads the state 1 from the memories	:MMEM:LOAD:STAT:REG 1
[Save/Recall]		
MEDIA		

SCPI Command Reference
Command list

Key Operation	Function	SCPI Command
EXT	Deletes the state from the memories	:MMEM EXT
INT	Deletes the state from the memories	:MMEM INT
SAVE DATA		
RETURN	Returns to the softkey display screen one level higher	
SAVE & STOP	Stores the state from the memories	:MMEM:STOR :MEM:CLE
START LOG	Enables the data buffer memory to store the measurement data	:MEM:FILL
SAVE DISPLAY	Stores the state from the memories	
No.		
DELETE	Deletes the state from the memories	:MMEM:DEL:REG
RECALL	Loads the state from the memories	:MMEM:LOAD:STAT:REG
SAVE	Stores the state from the memories	:MMEM:STOR:STAT:REG
[System]		
SELF TEST		
TEST NO.	Selects the self-test number	
EXECUTE		
RETURN	Returns to the softkey display screen one level higher	
TEST START	Starts the self-test from the test number	
TEST STOP	Stops the self-test from the test number	
SERVICE		
MORE		
RETURN	Returns to the softkey display screen one level higher	
SAVE SYS INFO	Stores the state from the memories	
SYSTEM CONFIG		
BEEPER ENABLED		
OFF	Disables a beep sound.	:SYST:BEEP:STAT OFF
ON	Enables a beep sound.	:SYST:BEEP:STAT ON
BEEPER TONE		
TONE 1	Selects beep tone 1	:SYST:BEEP:TONE 1
TONE 2	Selects beep tone 2	:SYST:BEEP:TONE 2
TONE 3	Selects beep tone 3	:SYST:BEEP:TONE 3
TONE 4	Selects beep tone 4	:SYST:BEEP:TONE 4

Key Operation	Function	SCPI Command
TONE 5	Selects beep tone 5	:SYST:BEEP:TONE 5
DATE/TIME		
DATE		
DAY	Sets the date of the internal clock	:SYST:DATE
MONTH	Sets the date of the internal clock	:SYST:DATE
RETURN	Returns to the softkey display screen one level higher	
YEAR	Sets the date of the internal clock	:SYST:DATE
TIME		
HOURL	Sets the time of the internal clock	:SYST:TIME
MINUTE	Sets the time of the internal clock	:SYST:TIME
RETURN	Returns to the softkey display screen one level higher	
SECOND	Sets the time of the internal clock	:SYST:TIME
GPIB ADDR	Sets the GPIB address	:SYST:COMM:GPIB:SELF:ADD R
IP CONFIG		
AUTO	Sets the IP address to AUTO	:SYST:COMM:LAN:SELF:CON F AUTO
MANUAL	Sets the IP address to MANUAL	:SYST:COMM:LAN:SELF:CON F MAN
RESTART NETWORK	Restarts the network	:SYST:COMM:LAN:SELF:REST
MANUAL GATEWAY		
ENTER	Sets the static Gateway address	:SYST:COMM:LAN:SELF:DGA T
RESTART NETWORK	Restarts the network	:SYST:COMM:LAN:SELF:REST
MANUAL IP ADDR		
ENTER	Sets the static IP address	:SYST:COMM:LAN:SELF:ADD R
RESTART NETWORK	Restarts the network	:SYST:COMM:LAN:SELF:REST
MANUAL SUBNET MASK		
ENTER	Sets the static Subnet Mask.	:SYST:COMM:LAN:SELF:SMA S
RESTART NETWORK	Restarts the network	:SYST:COMM:LAN:SELF:REST
TIME ZONE	Sets the time zone	:SYST:TZON

SCPI Command Reference
Command list

Key Operation	Function	SCPI Command
SYSTEM INFO		
CURR BIAS I/F		
OFF	Disables the current bias I/F	:CONT:CBI:STAT OFF
ON	Enables the current bias I/F	:CONT:CBI:STAT ON
HANDLER I/F		
OFF	Disables the handler I/F	:CONT:HAND:STAT OFF
ON	Enables the handler I/F	:CONT:HAND:STAT ON
SCANNER I/F		
OFF	Disables the scanner I/F	:CONT:SCAN:STAT OFF
ON	Enables the scanner I/F	:CONT:SCAN:STAT ON
[Trigger]	Triggers the unit	:TRIG:IMM

- *1. The field name changes depending on the list sweep parameter.
- *2. The field name changes when entering a comment.

Data Processing

The internal data processing flowchart for the E4980A is shown in Figure 9-1.

Figure 9-1 Data Processing Flowchart

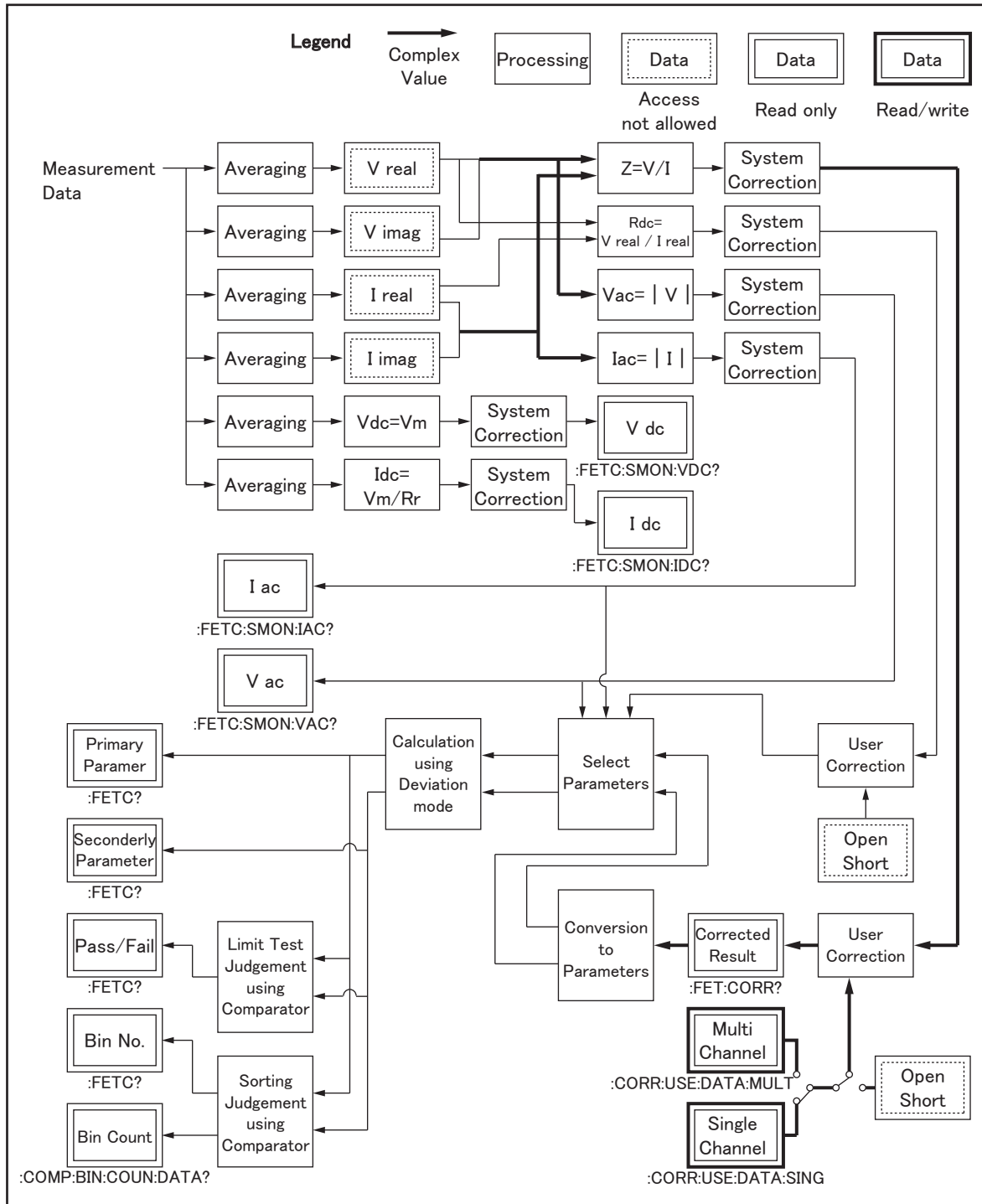

e4980aue1178

10 Sample Program

This chapter describes sample programs of the E4980A. The programs are written in VBA macro.

Set Up Measurement Conditions and LCD Display

This application program sets the measurement conditions and the LCD display of the E4980A.

The program of Example 10-1 is described in detail below. Each explanation below is inserted as a comment line in the program. For details on the VISA functions, refer to the I/O Library Suite manual.

Configuration	Assigns variables and enables error handling by the subroutine named ErrorHandler
Open Instrument	Assigns a USB address or GPIB address to the I/O bus.
Setup Start	Sets the measurement conditions and the LCD display.
Setup End	Closes the I/O bus.
ErrorProc	Displays an error number when an error occurs.
ErrorCheck	A subroutine to check whether an error occurs when the I/O Library Suite function is executed.
SelectLCR	A subroutine to change assignment of the I/O bus and address setting according to the selection of a drop down list in the B3 cell of the “Control Panel” sheet.

Example 10-1 **Setting measurement conditions and screen display**

```

Sub Example_1()

    '=====  

    ' Configuration  

    '=====  

    Dim defrm As Long           'Session to Default Resource  

    Manager  

    Dim Agte4980a As Long       'Session to instrument  

    On Error GoTo ErrorHandler  

    '=====  

    ' Open Instrument  

    '=====  

    ErrorCheck viOpenDefaultRM(defrm)  

    Call selectLCR(defrm, Agte4980a)  

    '=====  

    ' Setup Start  

    '=====  

    Cells(12, 2).Value = "Start to set configuration."  

    ErrorCheck viVPrintf(Agte4980a, "DISP:PAGE MSET" + vbLf, 0)  

    ErrorCheck viVPrintf(Agte4980a, "DISP:LINE " & "Control Example" & ""  

+ vbLf, 0)  

    ErrorCheck viVPrintf(Agte4980a, "FUNC:IMP ZTD" + vbLf, 0)  

    ErrorCheck viVPrintf(Agte4980a, "FREQ 1E6" + vbLf, 0)  

    ErrorCheck viVPrintf(Agte4980a, "VOLT 1" + vbLf, 0)  

    ErrorCheck viVPrintf(Agte4980a, "TRIG:SOUR BUS" + vbLf, 0)  

    ErrorCheck viVPrintf(Agte4980a, "AMPL:ALC ON" + vbLf, 0)  

    ErrorCheck viVPrintf(Agte4980a, "OUTP:DC:ISOL ON" + vbLf, 0)  

    ErrorCheck viVPrintf(Agte4980a, "FUNC:IMP:RANG 1E4" + vbLf, 0)  

    ErrorCheck viVPrintf(Agte4980a, "BIAS:VOLT 5" + vbLf, 0)  

    ErrorCheck viVPrintf(Agte4980a, "APER LONG,4" + vbLf, 0)  

    ErrorCheck viVPrintf(Agte4980a, "FUNC:SMON:VAC ON" + vbLf, 0)  

    ErrorCheck viVPrintf(Agte4980a, "FUNC:SMON:IAC ON" + vbLf, 0)  

    ErrorCheck viVPrintf(Agte4980a, "TRIG:DEL 5" + vbLf, 0)  

    ErrorCheck viVPrintf(Agte4980a, "FUNC:DEV1:MODE ABS" + vbLf, 0)  

    ErrorCheck viVPrintf(Agte4980a, "FUNC:DEV2:MODE ABS" + vbLf, 0)  

    ErrorCheck viVPrintf(Agte4980a, "FUNC:DEV1:REF 10000" + vbLf, 0)  

    ErrorCheck viVPrintf(Agte4980a, "FUNC:DEV2:REF 1" + vbLf, 0)  

    Cells(12, 2).Value = "End to set configuration."  

    '=====  

    ' Setup End  

    '=====  

    Call viClose(defrm)  

    End

```

Sample Program

Set Up Measurement Conditions and LCD Display

```
'=====
' ErrorProc
'=====

ErrorHandler:

    ' Display the error message
    MsgBox "*** Error : " + Error$, MB_ICON_EXCLAMATION
    End

End Sub

'=====
' ErrorCheck
'=====

Sub ErrorCheck(ErrorStatus As Long)
    Dim strVisaErr As String * 500
    '
    ' Check if VISA Error
    '
    If ErrorStatus <> VI_SUCCESS Then
        Call viStatusDesc(defrm, ErrorStatus, strVisaErr)
        MsgBox "*** Error : " + strVisaErr
    End If
End Sub

End Sub

'=====
' SelectLCR
'=====

Sub selectLCR(defrm As Long, Agte4980a As Long)
    Dim Lcr As String
    Lcr = Worksheets("ControlPanel").Range("B3").Value
    If Lcr = "GPIB" Then
        ErrorCheck viOpen(defrm, "GPIB0::17::INSTR", 0, 0,
Agte4980a)
    End If
    If Lcr = "USB" Then
        ErrorCheck viOpen(defrm,
"USB0::2391::2313::MY12345678::0::INSTR", 0, 0, Agte4980a)
    End If
End Sub

End Sub
```

Detecting End of Measurement

This application program detects the end of measurement with the status byte after the E4980A is triggered.

The program of Example 10-2 is described in detail below.

Configuration	Assigns variables and enables error handling by the subroutine named ErrorHandler.
Open Instrument	Assigns a USB address or GPIB address to the I/O bus. Also sets the attribute for timeout processing.
Setup Start	Sets the trigger and status byte.
STB Check	Waits until the status byte becomes 192. Displays the status byte while waiting and again after processing.
Setup End	Closes the I/O bus.
ErrorProc	Displays an error number when an error occurs.

Sample Program Detecting End of Measurement

Example 10-2 Detecting End of Measurement

```
Sub Example_2()  
  
    '=====  
    ' Configuration  
    '=====  
  
    Dim defrm As Long           'Session to Default Resource  
Manager  
    Dim Agte4980a As Long      'Session to instrument  
    Dim Result As String * 500  
    Dim Res As Variant  
    Dim i As Integer, StbStatus As Integer  
    Const TimeOutTime = 30000  
  
    On Error GoTo ErrorHandler  
  
    '=====  
    ' Open Instrument  
    '=====  
  
    ErrorCheck viOpenDefaultRM(defrm)  
    Call selectLCR(defrm, Agte4980a)  
    ErrorCheck viSetAttribute(Agte4980a, VI_ATTR_TMO_VALUE,  
TimeOutTime)  
  
    '=====  
    ' Setup Start  
    '=====  
  
    ErrorCheck viVPrintf(Agte4980a, "*RST;*CLS" + vbLf, 0)  
    ErrorCheck viVPrintf(Agte4980a, "*SRE 0" + vbLf, 0)  
    ErrorCheck viVPrintf(Agte4980a, "STAT:OPER:ENAB 0" + vbLf, 0)  
    ErrorCheck viVPrintf(Agte4980a, "TRIG:SOUR BUS" + vbLf, 0)  
    ErrorCheck viVPrintf(Agte4980a, "APER LONG,3" + vbLf, 0)  
  
    ErrorCheck viVPrintf(Agte4980a, "ABOR;INIT" + vbLf, 0)  
    ErrorCheck viVPrintf(Agte4980a, "TRIG:IMM" + vbLf, 0)  
  
    ErrorCheck viVPrintf(Agte4980a, "*SRE 128" + vbLf, 0)  
    ErrorCheck viVPrintf(Agte4980a, "STAT:OPER:ENAB 16" + vbLf,  
0)  
  
    '=====  
    ' STB Check  
    '=====  
  
    Do  
        ErrorCheck viReadSTB(Agte4980a, StbStatus)  
        Range("B12").Value = StbStatus  
    Loop Until StbStatus = 192  
  
    ErrorCheck viVPrintf(Agte4980a, "*CLS" + vbLf, 0)  
  
    ErrorCheck viReadSTB(Agte4980a, StbStatus)  
    Range("D12").Value = StbStatus
```

```
'=====
' Setup End
'=====

Call viClose(defrm)

End

'=====
' ErrorProc
'=====

ErrorHandler:
' Display the error message
MsgBox "*** Error : " + Error$, MB_ICON_EXCLAMATION
End

End Sub
```

Read Measurement Results

This section describes how to read measurement results in ASCII format and BINARY format using sample programs. The following samples show three methods for each data format: comparator, data buffer memory, and list sweep.

Read measurement data in ASCII format (Comparator)

This application program reads measurement data in ASCII format with the comparator function on.

The program of Example 10-3 is described below.

Configuration	Assigns variables and enables error handling by the subroutine named ErrorHandle.
Open Instrument	Assigns a USB address or GPIB address to the I/O bus. Also sets the time for timeout.
Setup Start	Sets the trigger, comparator function, and data format.
Meas Read	Reads the measurement data using the :FETCh? command, separates the returned ASCII format character string data with commas, and displays them individually.
Setup End	Closes the I/O bus.
ErrorProc	Displays an error number when an error occurs.

Example 10-3

Read measurement results (ASCII format, comparator)

```
Sub Example_3_1()  
  
    '=====  
    ' Configuration  
    '=====  
  
    Dim defrm As Long           'Session to Default Resource  
Manager  
    Dim Agte4980a As Long       'Session to instrument  
    Dim Result As String * 500  
    Dim Res As Variant  
    Dim Nop As Integer, i As Integer  
    Const TimeOutTime = 30000  
  
    On Error GoTo ErrorHandler  
  
    '=====
```

```

' Open Instrument
'=====

ErrorCheck viOpenDefaultRM(defrm)
Call selectLCR(defrm, Agte4980a)
ErrorCheck viSetAttribute(Agte4980a, VI_ATTR_TMO_VALUE,
TimeOutTime)

'=====
' Setup Start
'=====

Nop = 4

ErrorCheck viVPrintf(Agte4980a, "*RST;*CLS" + vbLf, 0)
ErrorCheck viVPrintf(Agte4980a, "FORM ASC" + vbLf, 0)
ErrorCheck viVPrintf(Agte4980a, "APER LONG,5" + vbLf, 0)
ErrorCheck viVPrintf(Agte4980a, "TRIG:SOUR BUS" + vbLf, 0)
ErrorCheck viVPrintf(Agte4980a, "COMP ON" + vbLf, 0)
ErrorCheck viVPrintf(Agte4980a, "INIT:CONT OFF" + vbLf, 0)
ErrorCheck viVPrintf(Agte4980a, "INIT:IMM" + vbLf, 0)

ErrorCheck viVPrintf(Agte4980a, "TRIG:IMM" + vbLf, 0)

'=====
' Meas Read
'=====

ErrorCheck viVPrintf(Agte4980a, "FETCh?" + vbLf, 0)
ErrorCheck viVScanf(Agte4980a, "%t", Result)

Res = Split(Result, ",")
For i = 0 To Nop - 1
    Cells(13, i + 2).Value = Val(Res(i))
Next i

'=====
' Setup End

```

Sample Program

Read Measurement Results

```
'=====`

Call viClose(defrm)

End

'=====
' ErrorProc
'=====`

ErrorHandler:
' Display the error message
MsgBox "*** Error : " + Error$, MB_ICON_EXCLAMATION
End

End Sub
```

Read measurement data in ASCII format (Data buffer memory)

This application program reads measurement data in ASCII format with the comparator function on by using the data buffer memory.

The program of Example 10-4 is described below.

Configuration	Assigns variables and enables error handling by the subroutine named ErrorHandle
Open Instrument	Assigns a USB address or GPIB address to the I/O bus. Also sets the time for timeout.
Setup Start	Sets the trigger, comparator function, memory buffer, and data format.
Mem Buf Read	Reads the measurement data stored in the memory buffer, separates the returned ASCII format character string data with commas, and displays them individually. Then the memory buffer is cleared.
Setup End	Closes the I/O bus.
ErrorProc	Displays an error number when an error occurs.

Example 10-4

Read measurement results (ASCII format, data buffer memory)

```
Sub Example_3_2()

    '=====
    ' Configuration
    '=====

    Dim defrm As Long           'Session to Default Resource
Manager
    Dim Agte4980a As Long       'Session to instrument
    Dim Result As String * 500
    Dim Res As Variant
    Dim NoofMeas As Integer, i As Integer, j As Integer, k As
Integer
    Dim outEventType As Long, outEventContext As Long
    Const TimeOutTime = 30000

    On Error GoTo ErrorHandler

    '=====
    ' Open Instrument
    '=====

    ErrorCheck viOpenDefaultRM(defrm)
    Call selectLCR(defrm, Agte4980a)
```

Sample Program

Read Measurement Results

```
ErrorCheck viSetAttribute(Agte4980a, VI_ATTR_TMO_VALUE,
TimeOutTime)

'=====
' Setup Start
'=====

NoofMeas = 5

ErrorCheck viVPrintf(Agte4980a, "*RST;*CLS" + vbLf, 0)
ErrorCheck viVPrintf(Agte4980a, "FORM ASC" + vbLf, 0)
ErrorCheck viVPrintf(Agte4980a, "TRIG:SOUR BUS" + vbLf, 0)
ErrorCheck viVPrintf(Agte4980a, "MEM:DIM DBUF, " +
CStr(NoofMeas) + vbLf, 0)
ErrorCheck viVPrintf(Agte4980a, "MEM:CLE DBUF" + vbLf, 0)
ErrorCheck viVPrintf(Agte4980a, "MEM:FILL DBUF" + vbLf, 0)
ErrorCheck viVPrintf(Agte4980a, "APER LONG,5" + vbLf, 0)

For i = 1 To NoofMeas
    ErrorCheck viVPrintf(Agte4980a, ":INIT:IMM;:TRIG:IMM" +
vbLf, 0)
Next i

'=====
' Mem Buf Read
'=====

ErrorCheck viVPrintf(Agte4980a, "MEM:READ? DBUF" + vbLf, 0)
ErrorCheck viVScanf(Agte4980a, "%t", Result)

Res = Split(Result, ",")
For i = 0 To (NoofMeas * 4) - 1
    j = i Mod 4
    k = i \ 4
    Cells(k + 24, j + 2).Value = Val(Res(i))
Next i

ErrorCheck viVPrintf(Agte4980a, "MEM:CLE DBUF" + vbLf, 0)
```

```
'=====
' Setup End
'===== `

Call viClose(defrm)

End

'=====
' ErrorProc
'===== `

ErrorHandler:
' Display the error message
MsgBox "*** Error : " + Error$, MB_ICON_EXCLAMATION
End

End Sub
```

Sample Program
Read Measurement Results

Read measurement data in ASCII format (List sweep)

This application program performs a list sweep and reads the measured value and limit judgement at each measurement point in ASCII format.

The program of Example 10-5 is described below.

Configuration	Assigns variables and enables error handling by the subroutine named ErrorHandler.
Open Instrument	Assigns a USB address or GPIB address to the I/O bus. Also sets the time for timeout.
Setup Start	Sets the trigger, list sweep, and data format.
List Read	Reads the measurement data, separates the ASCII format character string data with commas, and displays them individually.
Setup End	Closes the I/O bus.
ErrorProc	Displays an error number when an error occurs.

Example 10-5

Read measurement results (ASCII format, list sweep)

```
Sub Example_3_3 ()

    '=====
    ' Configuration
    '=====

    Dim defrm As Long           'Session to Default Resource
    Manager
    Dim Agte4980a As Long       'Session to instrument
    Dim Result As String * 500
    Dim Res As Variant
    Dim Nop As Long, i As Integer, j As Integer, k As Integer
    Const TimeOutTime = 30000

    On Error GoTo ErrorHandler

    '=====
    ' Open Instrument
    '=====

    ErrorCheck viOpenDefaultRM(defrm)
    Call selectLCR(defrm, Agte4980a)
    ErrorCheck viSetAttribute(Agte4980a, VI_ATTR_TMO_VALUE,
    TimeOutTime)
```

```
'=====
' Setup Start
'=====

Nop = 7 * 4

ErrorCheck viVPrintf(Agte4980a, "*RST;*CLS" + vbLf, 0)
ErrorCheck viVPrintf(Agte4980a, "TRIG:SOUR BUS" + vbLf, 0)
ErrorCheck viVPrintf(Agte4980a, "DISP:PAGE LIST" + vbLf, 0)
ErrorCheck viVPrintf(Agte4980a, "FORM ASC" + vbLf, 0)
ErrorCheck viVPrintf(Agte4980a, "LIST:MODE SEQ" + vbLf, 0)
ErrorCheck viVPrintf(Agte4980a, "LIST:FREQ
1E3,2E3,5E3,1E4,2E4,5E4,1E5" + vbLf, 0)
ErrorCheck viVPrintf(Agte4980a, "LIST:BAND1 A,100,200" + vbLf,
0)
ErrorCheck viVPrintf(Agte4980a, "LIST:BAND2 A,100,200" + vbLf,
0)
ErrorCheck viVPrintf(Agte4980a, "LIST:BAND3 A,100,200" + vbLf,
0)
ErrorCheck viVPrintf(Agte4980a, "LIST:BAND4 A,100,200" + vbLf,
0)
ErrorCheck viVPrintf(Agte4980a, "LIST:BAND5 A,100,200" + vbLf,
0)
ErrorCheck viVPrintf(Agte4980a, "LIST:BAND6 A,100,200" + vbLf,
0)
ErrorCheck viVPrintf(Agte4980a, "LIST:BAND7 A,100,200" + vbLf,
0)
ErrorCheck viVPrintf(Agte4980a, "INIT:CONT ON" + vbLf, 0)

ErrorCheck viVPrintf(Agte4980a, ":TRIG:IMM" + vbLf, 0)

'=====
' List Read
'=====

ErrorCheck viVPrintf(Agte4980a, ":FETC?" + vbLf, 0)

ErrorCheck viVScanf(Agte4980a, "%t", Result)
```

Sample Program

Read Measurement Results

```
Res = Split(Result, ",")
For i = 0 To Nop - 1
    j = i Mod 4
    k = i \ 4
    Cells(k + 39, j + 2).Value = Val(Res(i))
Next i

'=====
' Setup End
'=====

Call viClose(defrm)

End

'=====
' ErrorProc
'=====

ErrorHandler:
    ' Display the error message
    MsgBox "*** Error : " + Error$, MB_ICON_EXCLAMATION
End

End Sub
```

Read measurement data in BINARY (comparator)

This application program reads the measurement data in BINARY format when the comparator function is on.

The program of Example 10-6 is described below.

Configuration	Assigns variables and enables error handling by the subroutine named ErrorHandler
Open Instrument	Assigns a USB address or GPIB address to the I/O bus. Also sets the time for timeout.
Setup Start	Sets the trigger, comparator function, and data format.
Meas Read	Reads the measurement data using the :FETCh? command and displays the returned BINARY format array data individually.
Setup End	Close the I/O bus.
ErrorProc	Displays an error number when an error occurs.
BinaryAry Read	Sets the address of the array in which measured data is stored. A subroutine to set the returned BINARY format data in the array.

Example 10-6

Read measurement results (BINARY format, comparator)

```

Sub Example_3_4()

    '=====
    ' Configuration
    '=====

    Dim defrm As Long           'Session to Default Resource
Manager
    Dim Agte4980a As Long      'Session to instrument
    Dim Res() As Double
    Dim Nop As Long, i As Integer, j As Integer, k As Integer
    Const TimeOutTime = 30000

    On Error GoTo ErrorHandler

    '=====
    ' Open Instrument
    '=====

    ErrorCheck viOpenDefaultRM(defrm)
    Call selectLCR(defrm, Agte4980a)
    ErrorCheck viSetAttribute(Agte4980a, VI_ATTR_TMO_VALUE,
TimeOutTime)

```

Sample Program

Read Measurement Results

```
'=====
' Setup Start
'=====

ErrorCheck viVPrintf(Agte4980a, "*RST;*CLS" + vbLf, 0)
ErrorCheck viVPrintf(Agte4980a, "FORM REAL" + vbLf, 0)
ErrorCheck viVPrintf(Agte4980a, "APER LONG,1" + vbLf, 0)
ErrorCheck viVPrintf(Agte4980a, "TRIG:SOUR BUS" + vbLf, 0)
ErrorCheck viVPrintf(Agte4980a, "COMP ON" + vbLf, 0)
ErrorCheck viVPrintf(Agte4980a, "INIT:CONT OFF" + vbLf, 0)
ErrorCheck viVPrintf(Agte4980a, "INIT:IMM" + vbLf, 0)

ErrorCheck viVPrintf(Agte4980a, "TRIG:IMM" + vbLf, 0)

'=====
' Meas Read
'=====

ErrorCheck viVPrintf(Agte4980a, ":FETC?" + vbLf, 0)

Call Scpi_read_binary_double_array(Agte4980a, Res, Nop)

For i = 0 To 3
    Cells(13, i + 9).Value = Res(i)
Next i

'=====
' Setup End
'=====

Call viClose(defrm)

End

'=====
' ErrorProc
'=====
```



```
ErrorHandler:
    ' Display the error message
    MsgBox "*** Error : " + Error$, MB_ICON_EXCLAMATION
    End

End Sub

' =====
' BinaryAry Read
' =====

Sub Scpi_read_binary_double_array(vi As Long, data() As Double, Nop
As Long)
    Dim dblArray(10000) As Double
    Dim paramsArray(3) As Long
    Dim err As Long
    Dim i As Long
    Dim lf_eoi As String * 1

    Nop = UBound(dblArray) - LBound(dblArray) + 1
    paramsArray(0) = VarPtr(Nop)
    paramsArray(1) = VarPtr(dblArray(0))

    err = viVScanf(vi, "%#Zb%lt", paramsArray(0))
    If err <> 0 Then MsgBox "Binary Error"

    ReDim data(Nop - 1)
    For i = 0 To Nop - 1
        data(i) = dblArray(i)
    Next
End Sub
```

Sample Program
Read Measurement Results

Read measurement data in BINARY format (Data buffer memory)

This application program reads measurement data in BINARY format with the comparator function on by using the data buffer memory.

The program of Example 10-7 is described below.

Configuration	Assigns variables and enables error handling by the subroutine named ErrorHandler
Open Instrument	Assigns a USB address or GPIB address to the I/O bus. Also sets the time for timeout.
Setup Start	Sets the trigger, comparator function, memory buffer, and data format.
Mem Buf Read	Reads the measurement data stored in the memory buffer and displays the returned BINARY format array data individually. Then the memory buffer is cleared.
Setup End	Closes the I/O bus.
ErrorProc	Displays an error number when an error occurs.

Example 10-7

Reads measurement results (BINARY format, data buffer memory)

```
Sub Example_3_5 ()

    '=====
    ' Configuration
    '=====

    Dim defrm As Long           'Session to Default Resource
Manager
    Dim Agte4980a As Long       'Session to instrument
    Dim Res() As Double
    Dim Nop As Long, i As Integer, j As Integer, k As Integer
    Dim outEventType As Long, outEventContext As Long
    Const TimeOutTime = 30000

    On Error GoTo ErrorHandler

    '=====
    ' Open Instrument
    '=====

    ErrorCheck viOpenDefaultRM(defrm)
    Call selectLCR(defrm, Agte4980a)
    ErrorCheck viSetAttribute(Agte4980a, VI_ATTR_TMO_VALUE,
TimeOutTime)
```

```

NofMeas = 5

'=====
' Setup Start
'=====

ErrorCheck viVPrintf(Agte4980a, "*RST;*CLS" + vbLf, 0)
ErrorCheck viVPrintf(Agte4980a, "TRIG:SOUR BUS" + vbLf, 0)
ErrorCheck viVPrintf(Agte4980a, "COMP ON" + vbLf, 0)
ErrorCheck viVPrintf(Agte4980a, "APER LONG,5" + vbLf, 0)
ErrorCheck viVPrintf(Agte4980a, "FORM REAL" + vbLf, 0)
ErrorCheck viVPrintf(Agte4980a, "MEM:DIM DBUF, " + CStr(NofMeas)
+ vbLf, 0)
ErrorCheck viVPrintf(Agte4980a, "MEM:CLE DBUF" + vbLf, 0)
ErrorCheck viVPrintf(Agte4980a, "MEM:FILL DBUF" + vbLf, 0)
'
For i = 1 To NofMeas
    ErrorCheck viVPrintf(Agte4980a, ":INIT:IMM;:TRIG:IMM" +
vbLf, 0)
Next i

'=====
' Mem Buf Read
'=====

ErrorCheck viVPrintf(Agte4980a, "MEM:READ? DBUF" + vbLf, 0)

Call Scpi_read_binary_double_array(Agte4980a, Res, Nop)

For i = 0 To Nop - 1
    j = i Mod 4
    k = i \ 4
    Cells(k + 24, j + 9).Value = Res(i)
Next i

'=====
' Setup End

```

Sample Program

Read Measurement Results

```
'=====`

Call viClose(defrm)

End

'=====
' ErrorProc
'=====

ErrorHandler:
' Display the error message
MsgBox "*** Error : " + Error$, MB_ICON_EXCLAMATION
End

End Sub
```

Read measurement data in BINARY format (List sweep)

This application program performs a list sweep and reads the measured value and limit judgement at each measurement point in BINARY format.

The program of Example 10-8 is described below.

Configuration	Assigns variables and enables error handling by the subroutine named ErrorHandler.
Open Instrument	Assigns a USB address or GPIB address to the I/O bus. Also sets the time for timeout.
Setup Start	Sets the trigger, list sweep, and data format.
List Read	Reads the measurement data and displays the returned BINARY format array data individually.
Setup End	Closes the I/O bus.
ErrorProc	Displays an error number when an error occurs.

Example 10-8

Read measurement results (BINARY format, list sweep)

```
Sub Example_3_6()

    '=====
    ' Configuration
    '=====

    Dim defrm As Long           'Session to Default Resource
Manager
    Dim Agte4980a As Long       'Session to instrument
    Dim Res() As Double
    Dim Nop As Long, i As Integer, j As Integer, k As Integer
    Dim outEventType As Long, outEventContext As Long
    Const TimeOutTime = 30000

    On Error GoTo ErrorHandler

    '=====
    ' Open Instrument
    '=====

    ErrorCheck viOpenDefaultRM(defrm)
    Call selectLCR(defrm, Agte4980a)
    ErrorCheck viSetAttribute(Agte4980a, VI_ATTR_TMO_VALUE,
TimeOutTime)
```

Sample Program

Read Measurement Results

```
'=====
' Setup Start
'=====

ErrorCheck viVPrintf(Agte4980a, "*RST;*CLS" + vbLf, 0)
ErrorCheck viVPrintf(Agte4980a, "TRIG:SOUR BUS" + vbLf, 0)
ErrorCheck viVPrintf(Agte4980a, "DISP:PAGE LIST" + vbLf, 0)
ErrorCheck viVPrintf(Agte4980a, "FORM REAL,64" + vbLf, 0)
ErrorCheck viVPrintf(Agte4980a, "LIST:MODE SEQ" + vbLf, 0)
ErrorCheck viVPrintf(Agte4980a, "LIST:FREQ
1E3,2E3,5E3,1E4,2E4,5E4,1E5" + vbLf, 0)
ErrorCheck viVPrintf(Agte4980a, "LIST:BAND1 A,100,200" + vbLf,
0)
ErrorCheck viVPrintf(Agte4980a, "LIST:BAND2 A,100,200" + vbLf,
0)
ErrorCheck viVPrintf(Agte4980a, "LIST:BAND3 A,100,200" + vbLf,
0)
ErrorCheck viVPrintf(Agte4980a, "LIST:BAND4 A,100,200" + vbLf,
0)
ErrorCheck viVPrintf(Agte4980a, "LIST:BAND5 A,100,200" + vbLf,
0)
ErrorCheck viVPrintf(Agte4980a, "LIST:BAND6 A,100,200" + vbLf,
0)
ErrorCheck viVPrintf(Agte4980a, "LIST:BAND7 A,100,200" + vbLf,
0)
ErrorCheck viVPrintf(Agte4980a, "INIT:CONT ON" + vbLf, 0)
'
ErrorCheck viVPrintf(Agte4980a, ":TRIG:IMM" + vbLf, 0)

'=====
' List Read
'=====

ErrorCheck viVPrintf(Agte4980a, ":FETC?" + vbLf, 0)

Call Scpi_read_binary_double_array(Agte4980a, Res, Nop)

For i = 0 To Nop - 1
    j = i Mod 4
```

```
        k = i \ 4
        Cells(k + 39, j + 9).Value = Res(i)
    Next i

' =====
' Setup End
' ===== `

Call viClose(defrm)

End

' =====
' ErrorProc
' =====

ErrorHandler:
    ' Display the error message
    MsgBox "*** Error : " + Error$, MB_ICON_EXCLAMATION
End

End Sub
```

Save/Recall

This application program saves into/recalls from the E4980A's internal flash memory the status data by using the save/recall function.

The program of Example 10-9 is described below.

Configuration	Assigns variables and enables error handling by the subroutine named ErrorHandler
Open Instrument	Assigns a USB address or GPIB address to the I/O bus. Also sets the time for timeout.
SaveRecall	Saves into or recalls from the E4980A's register 1 the status data according to the contents of a specified cell. Also confirms whether each process finishes using the *OPC? query command.
Setup End	Close the I/O bus.
ErrorProc	Displays an error number when an error occurs.

Example 10-9

Save/Recall

```
Sub Example_4()  
  
    '=====  
    ' Configuration  
    '=====
```

Dim defrm As Long 'Session to Default Resource
Manager
Dim Agte4980a As Long 'Session to instrument
Dim Result As String * 200
Const TimeOutTime = 30000

On Error GoTo ErrorHandler

```
    '=====  
    ' Open Instrument  
    '=====
```

ErrorCheck viOpenDefaultRM(defrm)
Call selectLCR(defrm, Agte4980a)
ErrorCheck viSetAttribute(Agte4980a, VI_ATTR_TMO_VALUE,
TimeOutTime)

```
    '=====  
    ' SaveRecall  
    '=====
```

If Cells(9, 2).Value = "Save" Then
 ErrorCheck viVPrintf(Agte4980a, ":MMEM:STOR:STAT 1" + vbLf,
0)
Else
 ErrorCheck viVPrintf(Agte4980a, ":MMEM:LOAD:STAT 1" + vbLf,
0)
End If
ErrorCheck viVQueryf(Agte4980a, "*OPC?" + vbLf, "%t", Result)

```
If Cells(9, 2).Value = "Save" Then
    MsgBox ("State Save End")
Else
    MsgBox ("State Recall End")
End If

Cells(15, 2).Value = Trim(Result)

'=====
' Setup End
'=====

Call viClose(defrm)

End

'=====
' ErrorProc
'=====

ErrorHandler:
' Display the error message
MsgBox "*** Error : " + Error$, MB_ICON_EXCLAMATION
End

End Sub
```

Read/Write correction data at specified frequency points.

This application program performs correction at user-specified frequencies and reads/writes (uploads to E4980A) the correction data.

The program of Example 10-10 is described below.

Configuration	Assigns variables and enables error handling by the subroutine named ErrorHandler
Open Instrument	Assigns a USB address or GPIB address to the I/O bus. Also sets the time for timeout.
Setup Start	Executes various setup steps to perform data correction, such as displaying a CORRECTION page, setting the correction mode to SINGLE, and setting the correction type to RX.
Exec Correction	Performs OPEN/SHORT/LOAD correction. Assigns the frequency of 1 kHz to measurement point 1, 2 kHz to measurement point 2, and 5 kHz to measurement point 3 and then performs correction.
Read Correction	Reads the correction data, separates the data, and displays them individually on a sheet.
Correction data uploading	Uploads the correction data. The string parameters separated by commas are generated from the displayed correction data on the sheet and then sent to the E4980A.
Setup End	Close the I/O bus.
ErrorProc	Displays an error number when an error occurs.

NOTE

It is not possible to read/write the correction data in the correction based on all frequency points.

Example 10-10

Read/Write correction data

```
Sub Example_5()

    '=====
    ' Configuration
    '=====

    Dim defrm As Long           'Session to Default Resource
    Manager

    Dim Agte4980a As Long      'Session to instrument

    Dim Res1 As Variant

    Dim Result As String * 50000
```

Read/Write correction data at specified frequency points.

```

Dim SendCorr As String
Dim i As Integer, FreqPoint As Integer, Std As Integer, Para As Integer, j As Integer, k As Integer
Dim Spot_Lop As Integer, Spot_Freq(10) As String
Dim CalData(200, 2, 1) As Variant
Const StdOpen As Integer = 0, StdShort As Integer = 1, StdLoad As Integer = 2
Const PriPara As Integer = 0, SecondPara As Integer = 1
Dim err As Long
Const TimeOutTime = 30000

On Error GoTo ErrorHandler

'=====
' Open Instrument
'=====

ErrorCheck viOpenDefaultRM(defrm)
Call selectLCR(defrm, Agte4980a)
ErrorCheck viSetAttribute(Agte4980a, VI_ATTR_TMO_VALUE, TimeOutTime)

'=====
' Setup Start
'=====

ErrorCheck viVPrintf(Agte4980a, "*RST;*CLS" + vbLf, 0)
ErrorCheck viVPrintf(Agte4980a, "DISP:PAGE CSET" + vbLf, 0)

ErrorCheck viVPrintf(Agte4980a, "CORR:LOAD:TYPE RX" + vbLf, 0)
ErrorCheck viVPrintf(Agte4980a, "TRIG:SOUR BUS" + vbLf, 0)
ErrorCheck viVPrintf(Agte4980a, "CORR:METH SING" + vbLf, 0)

'=====
' Exec Correction
'=====

Spot_Freq(1) = "1E3"
Spot_Freq(2) = "2E3"

```

Sample Program

Read/Write correction data at specified frequency points.

```
Spot_Freq(3) = "5E3"
MsgBox ("Connect Open Termination.")
For Spot_Lop = 1 To 3
    ErrorCheck viVPrintf(Agte4980a, "CORR:SPOT" &
Trim(Str(Spot_Lop)) & ":FREQ " & Spot_Freq(Spot_Lop) + vbLf, 0)
    ErrorCheck viVPrintf(Agte4980a, "CORR:SPOT" &
Trim(Str(Spot_Lop)) & ":STAT ON" + vbLf, 0)
    ErrorCheck viVPrintf(Agte4980a, "CORR:SPOT" &
Trim(Str(Spot_Lop)) & ":OPEN" + vbLf, 0)
    ErrorCheck viVQueryf(Agte4980a, "*OPC?" + vbLf, "%t",
Result)
Next Spot_Lop

MsgBox ("Connect Short Termination.")
For Spot_Lop = 1 To 3
    ErrorCheck viVPrintf(Agte4980a, "CORR:SPOT" &
Trim(Str(Spot_Lop)) & ":SHOR" + vbLf, 0)
    ErrorCheck viVQueryf(Agte4980a, "*OPC?" + vbLf, "%t",
Result)
Next Spot_Lop

MsgBox ("Connect Load Standard.")
For Spot_Lop = 1 To 3
    ErrorCheck viVPrintf(Agte4980a, "CORR:SPOT" &
Trim(Str(Spot_Lop)) & ":LOAD" + vbLf, 0)
    ErrorCheck viVQueryf(Agte4980a, "*OPC?" + vbLf, "%t",
Result)
Next Spot_Lop

MsgBox ("Calibration End.")

'=====
' Read Correction
'=====

ErrorCheck viVQueryf(Agte4980a, "CORR:USE:DATA:SING?" + vbLf,
"%t", Result)
Res1 = Split(Result, ",")
i = 0
For FreqPoint = 1 To 201
    For Std = StdOpen To StdLoad
```

Read/Write correction data at specified frequency points.

```

For Para = PriPara To SecondPara
    CalData(FreqPoint - 1, Std, Para) = Res1(i)
    j = i Mod 6
    k = i \ 6
    Cells(k + 13, j + 2).Value = Res1(i)
    i = i + 1
Next Para
Next Std
Next FreqPoint

MsgBox ("Reading correction data completed.")

'=====
' Correction data uploading
'=====

SendCorr = ""
i = 0
For FreqPoint = 1 To 201
    For Std = StdOpen To StdLoad
        For Para = PriPara To SecondPara
            j = i Mod 6
            k = i \ 6
            SendCorr = SendCorr & Cells(k + 13, j + 2).Value
            i = i + 1
            If i < 1206 Then
                SendCorr = SendCorr & ","
            End If
        Next Para
    Next Std
Next FreqPoint

ErrorCheck viVPrintf(Agte4980a, "CORR:USE:DATA:SING " + SendCorr
+ vbLf, 0)
ErrorCheck viVQueryf(Agte4980a, "*OPC?" + vbLf, "%t", Result)

MsgBox ("Sending correction data completed.")

```

Sample Program

Read/Write correction data at specified frequency points.

```
'=====
' Setup End
'=====

Call viClose(defrm)

End

'=====
' ErrorProc
'=====

ErrorHandler:
' Display the error message
MsgBox "*** Error : " + Error$, MB_ICON_EXCLAMATION
End

End Sub
```

11 Specifications and Supplemental Information

This chapter gives specifications and supplemental information for the Agilent E4980A Precision LCR meter.

Definitions

All specifications apply to the conditions of a 0°C to 55°C temperature range, unless otherwise stated, and 30 minutes after the instrument has been turned on.

Specifications (spec.): Warranted performance. Specifications include guardbands to account for the expected statistical performance distribution, measurement uncertainties, and changes in performance due to environmental conditions.

Supplemental Information is provided as information that is useful in operating the instrument but that is not covered by the product warranty. This information is classified as either typical or nominal.

Typical (typ.): Expected performance of an average unit without taking guardbands into account.

Nominal (nom.): A general descriptive term that does not imply a level of performance.

How to Use Tables

When measurement conditions fall under multiple categories in a table, apply the best value.

For example, the basic accuracy of Ab (refer to “Basic accuracy” on page 411) is 0.10% under the following conditions.

Measurement time mode	SHORT
Test frequency	125 Hz
Test signal voltage	0.3 Vrms

Basic Specifications

Measurement Functions

Measurement Parameters

- Cp-D, Cp-Q, Cp-G, Cp-Rp
- Cs-D, Cs-Q, Cs-Rs
- Lp-D, Lp-Q, Lp-G, Lp-Rp, Lp-Rdc^{*1}
- Ls-D, Ls-Q, Ls-Rs, Ls-Rdc^{*1}
- R-X
- Z-qd, Z-qr
- G-B
- Y-qd, Y-qr
- Vdc-Idc^{*1}

where

Cp:	Capacitance value measured with parallel-equivalent circuit model
Cs:	Capacitance value measured with series-equivalent circuit model
Lp:	Inductance value measured with parallel-equivalent circuit model
Ls:	Inductance value measured with series-equivalent circuit model
D:	Dissipation factor
Q:	Quality factor (inverse of D)
G:	Equivalent parallel conductance measured with parallel-equivalent circuit model
Rp:	Equivalent parallel resistance measured with parallel-equivalent circuit model
Rs:	Equivalent series resistance measured with series-equivalent circuit model
Rdc:	Direct-current resistance
R:	Resistance
X:	Reactance
Z:	Impedance
Y:	Admittance
qd:	Phase angle of impedance/admittance (degree)
qr:	Phase angle of impedance/admittance (radian)

^{*1}. Option 001 is required.

Specifications and Supplemental Information

Basic Specifications

B: Susceptance
Vdc: Direct-current voltage
Idc: Direct-current electricity

Deviation measurement function

Deviation from reference value and percentage of deviation from reference value can be output as the result.

Equivalent circuits for measurement

Parallel, Series

Impedance range selection

Auto (auto range mode), manual (hold range mode)

Trigger mode

Internal trigger (INT), manual trigger (MAN), external trigger (EXT), GPIB trigger (BUS)

Trigger delay time

Range	0 s to 999 s
Resolution	100 μ s (0 s to 100 s) 1 ms (100 s to 999 s)

Step delay time

Range	0 s - 999 s
Resolution	100 μ s (0 s to 100 s) 1 ms (100 s to 999 s)

Measurement terminal

Four-terminal pair

Test cable length

0 m, 1 m, 2 m, 4 m

Measurement time modes

Short mode, medium mode, long mode

For the measurement time in each mode, refer to "Measurement time" on page 437.

Averaging

Range	1 to 256 measurements
Resolution	1

Test signal

Test frequencies

Test frequencies	20 Hz to 2 MHz
Resolution	0.01 Hz (20 Hz to 99.99 Hz) 0.1 Hz (100 Hz to 999.9 Hz) 1 Hz (1 kHz to 9.999 kHz) 10 Hz (10 kHz to 99.99 kHz) 100 Hz (100 kHz to 999.9 kHz) 1 kHz (1 MHz to 2 MHz)
Measurement accuracy	± 0.01%

Test signal modes

Normal	Program selects voltage or current at the measurement terminals when they are opened or short-circuited, respectively.
Constant	Maintains selected voltage or current at the device under test (DUT) independently of changes in impedance of DUT.

Signal level

Table 11-1

Test signal voltage

Range	0 Vrms to 2.0 Vrms	
Resolution	100 μVrms (0 Vrms to 0.2 Vrms) 200 μVrms (0.2 Vrms to 0.5 Vrms) 500 μVrms (0.5 Vrms to 1 Vrms) 1 mVrms (1 Vrms to 2 Vrms)	
Accuracy	Normal	±(10% + 1 mVrms) (Test Frequency ≤ 1 MHz: spec. Test Frequency > 1 MHz: typ.)
	Constant*1	±(6% + 1 mVrms) (Test Frequency ≤ 1 MHz: spec. Test Frequency > 1 MHz: typ.)

*1. When auto level control function is on.

Table 11-2

Test signal current

Range	0 Arms to 20 mArms
Resolution	1 μArms (0 Arms to 2 mArms) 2 μArms (2 mArms to 5 mArms) 5 μArms (5 mArms to 10 mArms) 10 μArms (10 mArms to 20 mArms)

Table 11-2 Test signal current

Accuracy	Normal	$\pm(10\% + 10 \mu\text{Arms})$ (Test Frequency ≤ 1 MHz: spec. Test Frequency > 1 MHz: typ.)
	Constant ^{*1}	$\pm(6\% + 10 \mu\text{Arms})$ (Test Frequency ≤ 1 MHz: spec. Test Frequency > 1 MHz: typ.)

*1. When auto level control function is on.

Output impedance

100 Ω (nominal)

Test signal level monitor function

- Test signal voltage and test signal current can be monitored.
- Level monitor accuracy:

Table 11-3 Test signal voltage level monitor accuracy (Vac)

Test signal voltage ^{*1}	Test Frequency	Specification
5 mVrms to 2 Vrms	≤ 1 MHz	$\pm (3\% \text{ of reading value} + 0.5 \text{ mVrms})$
	> 1 MHz	$\pm (6\% \text{ of reading value} + 1 \text{ mVrms})$

*1. This is not an output value but a displayed test signal level.

Table 11-4 Test signal current level monitor accuracy (Iac)

Test signal current ^{*1}	Test Frequency	Specification
50 μArms to 20 mArms	≤ 1 MHz	$\pm (3\% \text{ of reading value} + 5 \mu\text{Arms})$
	> 1 MHz	$\pm (6\% \text{ of reading value} + 10 \mu\text{Arms})$

*1. This is not an output value but a displayed test signal level.

Measurement display ranges

Table 11-5 shows the range of the measured value that can be displayed on the screen.

Table 11-5 Allowable display ranges for measured values

Parameter	Measurement display range
Cs, Cp	$\pm 1.000000 \text{ aF to } 999.9999 \text{ EF}$
Ls, Lp	$\pm 1.000000 \text{ aH to } 999.9999 \text{ EH}$
D	$\pm 0.000001 \text{ to } 9.999999$
Q	$\pm 0.01 \text{ to } 99999.99$

Table 11-5 Allowable display ranges for measured values

Parameter	Measurement display range
R, Rs, Rp, X, Z, Rdc	$\pm 1.000000 \text{ a}\Omega$ to $999.9999 \text{ E}\Omega$
G, B, Y	$\pm 1.000000 \text{ aS}$ to 999.9999 ES
Vdc	$\pm 1.000000 \text{ aV}$ to 999.9999 EV
Idc	$\pm 1.000000 \text{ aA}$ to 999.9999 EA
θ_r	$\pm 1.000000 \text{ arad}$ to 3.141593 rad
θ_d	$\pm 0.0001 \text{ deg}$ to 180.0000 deg
$\Delta\%$	$\pm 0.0001\%$ to 999.9999%

a 1×10^{-18}

E 1×10^{18}

Absolute measurement accuracy

The following equations are used to calculate absolute accuracy.

Absolute accuracy Aa of |Z|, |Y|, L, C, R, X, G, B (L, C, X, and B accuracies apply when $D_x \leq 0.1$, R and G accuracies apply when $Q_x \leq 0.1$)

Equation 11-1 $Aa = Ae + Acal$

Aa Absolute accuracy (% of reading value)

Ae Relative accuracy (% of reading value)

Acal Calibration accuracy (%)

Where G accuracy is applied only to G-B measurements.

NOTE An alternating current magnetic field may influence the measurement result. In such case, the absolute measurement accuracy is as follows. (typical)

Equation 11-2 $Aa \times (1 + B \times (2 + 0.5/V_s))$

B Flux densities [Gauss]

Vs Signal voltage level [V]

D accuracy (when $D_x \leq 0.1$)

Equation 11-3 $De + \theta cal$

Dx Measured D value

De Relative accuracy of D

Specifications and Supplemental Information
Basic Specifications

θ_{cal} Calibration accuracy of θ (radian)

Q accuracy (When $Q_x \times Da < 1$)

Equation 11-4
$$\pm \frac{(Q_x^2 \times Da)}{(1 \mp Q_x \times Da)}$$

Q_x Measured Q value

Da Absolute accuracy of D

θ accuracy

Equation 11-5
$$\theta_e + \theta_{cal}$$

θ_e Relative accuracy of θ (deg)

θ_{cal} Calibration accuracy of θ (deg)

G accuracy (when $D_x \leq 0.1$)

Equation 11-6
$$B_x + Da \quad (S)$$

$$B_x = 2\pi f C_x = \frac{1}{2\pi f L_x}$$

D_x Measured D value

B_x Measured B value (S)

Da Absolute accuracy of D

f Test frequency (Hz)

C_x Measured C value (F)

L_x Measured L value (H)

where the accuracy of G is applied to Cp-G measurements.

Absolute accuracy of R_p (when $D_x \leq 0.1$)

Equation 11-7
$$\pm \frac{R_{px} \times Da}{D_x \mp Da} \quad (\Omega)$$

R_{px} Measured R_p value (Ω)

D_x Measured D value

Da Absolute accuracy of D

Absolute accuracy of R_s (when $D_x \leq 0.1$)

Equation 11-8
$$X_x \times Da \quad (\Omega)$$

$$X_x = \frac{1}{2\pi f C_x} = 2\pi f L_x$$

Dx	Measured D value
Xx	Measured X value (Ω)
Da	Absolute accuracy of D
f	Test frequency (Hz)
Cx	Measured C value (F)
Lx	Measured L value (H)

Relative accuracy

Relative accuracy includes stability, temperature coefficient, linearity, repeatability, and calibration interpolation error. Relative accuracy is specified when all of the following conditions are satisfied.

- o Warm-up time: 30 minutes
- o Test cable length: 0 m, 1 m, 2 m, or 4 m (Agilent 16047A/D/E)
- o A “Signal source overload” warning does not appear.
 When the test signal current exceeds a value in the following table, a “Signal source overload” warning appears.

Table 11-6 Test Signal Voltage

Test signal voltage	Test Frequency	Condition*1
≤ 2 Vrms	-	-
> 2 Vrms	≤ 1 MHz	the smaller value of either 110 mA or $130 \text{ mA} - 0.0015 \times V_{ac} \times (F_m / 1 \text{ MHz}) \times (L_{\text{cable}} + 0.5)$
	> 1 MHz	$70 \text{ mA} - 0.0015 \times V_{ac} \times (F_m / 1 \text{ MHz}) \times (L_{\text{cable}} + 0.5)$

*1. When the calculation result is a negative value, 0 A is applied.

Vac [V] Test signal voltage
 Fm [Hz] Test frequency
 L_cable [m] Cable length

- o OPEN and SHORT corrections have been performed.
- o Bias current isolation: Off
 The DC bias current does not exceed a set value within each range of the DC bias current.
 (For accuracy with bias current isolation, refer to “Supplemental Information” on page 436.)
- o The optimum impedance range is selected by matching the impedance of DUT to the effective measuring range.

|Z|, |Y|, L, C, R, X, G, and B accuracy (L, C, X, and B accuracies apply when $D_x \leq 0.1$, R and G accuracies apply when $Q_x \leq 0.1$)

Relative accuracy Ae is given as

Equation 11-9 $A_e = [A_b + Z_s / |Z_m| \times 100 + Y_o \times |Z_m| \times 100] \times K_t$

Zm Impedance of DUT
 Ab Basic accuracy
 Zs Short offset
 Yo Open offset
 Kt Temperature coefficient

D accuracy

D accuracy D_e is given as

- when $D_x \leq 0.1$

Equation 11-10 $D_e = \pm A_e / 100$

D_x Measured D value

A_e Relative accuracies of |Z|, |Y|, L, C, R, X, G, and B

- When $D_x > 0.1$, multiply D_e by $(1 + D_x)$

Q accuracy (when $Q \times D_e < 1$)

Q accuracy Q_e is given as

Equation 11-11
$$Q_e = \frac{(Q_x^2 \times D_e)}{(1 \mp Q_x \times D_e)}$$

Q_x Measured Q value

D_e Relative D accuracy

θ accuracy

θ accuracy θ_e is given as

Equation 11-12
$$\theta_e = \frac{180 \times A_e}{\pi \times 100} \quad (deg)$$

A_e Relative accuracies of
 |Z|, |Y|, L, C, R, X, G, and B

G accuracy (when $D_x \leq 0.1$)

G accuracy G_e is given as

Equation 11-13
$$G_e = B_x \times D_e \quad (S)$$

$$B_x = 2\pi f C_x = \frac{1}{2\pi f L_x}$$

G_e Relative G accuracy

D_x Measured D value

B_x Measured B value

D_e Relative D accuracy

f Test frequency

C_x Measured C value (F)

L_x Measured L value (H)

Rp accuracy (when Dx ≤ 0.1)

Rp accuracy Rpe is given as

Equation 11-14
$$Rpe = \pm \frac{Rpx \times De}{Dx \mp De} \quad (\Omega)$$

Rpe	Relative Rp accuracy
Rpx	Measured Rp value (Ω)
Dx	Measured D value
De	Relative D accuracy

Rs accuracy (when Dx ≤ 0.1)

Rs accuracy Rse is given as

Equation 11-15
$$Rse = Xx \times De \quad (\Omega)$$

$$Xx = \frac{1}{2\pi f Cx} = 2\pi f Lx$$

Rse	Relative Rs accuracy
Dx	Measured D value
Xx	Measured X value (Ω)
De	Relative D accuracy
f	Test frequency (Hz)
Cx	Measured C value (F)
Lx	Measured L value (H)

Example of C-D accuracy calculation

Measurement conditions

Test Frequency 1 kHz

Measured C value 100 nF

Test signal voltage 1 Vrms

Measurement time mode Medium

Measurement temperature 23°C

Ab = 0.05%

$$|Zm| = 1 / (2\pi \times 1 \times 10^3 \times 100 \times 10^{-9}) = 1590 \Omega$$

$$Zs = 0.6 \text{ m}\Omega \times (1 + 0.400 / 1) \times (1 + \sqrt{(1000 / 1000)}) = 1.68 \text{ m}\Omega$$

$$Yo = 0.5 \text{ nS} \times (1 + 0.100 / 1) \times (1 + \sqrt{(100 / 1000)}) = 0.72 \text{ nS}$$

$$\text{C accuracy: Ae} = [0.05 + 1.68\text{m} / 1590 \times 100 + 0.72\text{n} \times 1590 \times 100] \times 1 = 0.05\%$$

$$\text{D accuracy: De} = 0.05 / 100 = 0.0005$$

Basic accuracy

Basic accuracy A_b is given below.

Table 11-7 Measurement time mode = SHORT

Test Frequency [Hz]	Test signal voltage				
	5 mVrms to 50 mVrms	50 mVrms to 0.3 Vrms	0.3 Vrms to 1 Vrms	1 Vrms to 10 Vrms	10 Vrms to 20 Vrms
20 to 125	$(0.6\%) \times (50 \text{ mVrms} / V_s)$	0.60%	0.30%	0.30%	0.30%
125 to 1 M	$(0.2\%) \times (50 \text{ mVrms} / V_s)$	0.20%	0.10%	0.15%	0.15%
1 M to 2 M	$(0.4\%) \times (50 \text{ mVrms} / V_s)$	0.40%	0.20%	0.30%	0.30%

Table 11-8 Measurement time mode = MED, LONG

Test Frequency [Hz]	Test signal voltage				
	5 mVrms to 30 mVrms	30 mVrms to 0.3 Vrms	0.3 Vrms to 1 Vrms	1 Vrms to 10 Vrms	10 Vrms to 20 Vrms
20 to 100	$(0.25\%) \times (30 \text{ mVrms} / V_s)$	0.25%	0.10%	0.15%	0.15%
100 to 1 M	$(0.1\%) \times (30 \text{ mVrms} / V_s)$	0.10%	0.05%	0.10%	0.15%
1 M to 2 M	$(0.2\%) \times (30 \text{ mVrms} / V_s)$	0.20%	0.10%	0.20%	0.30%

V_s [Vrms] Test signal voltage

Effect by impedance of DUT

For impedance of DUT below 30Ω , the following value is added.

Test Frequency [Hz]	Impedance of DUT	
	$1.08 \Omega < Z_x < 30 \Omega$	$ Z_x \leq 1.08 \Omega$
20 to 1 M	0.05%	0.10%
1 M to 2 M	0.10%	0.20%

Specifications and Supplemental Information
Basic Specifications

For impedance of DUT over 9.2 kΩ, the following value is added.

Test Frequency [Hz]	Impedance of DUT	
	9.2 kΩ ≤ Z _x < 92 kΩ	92 kΩ ≤ Z _x
10 k to 100 k	0%	0.05%
100 k to 1 M	0.05%	0.05%
1 M to 2 M	0.10%	0.10%

Effect of cable extension

When the cable is extended, the following element is added for each meter of extension.

$$0.015\% \times (F_m / 1 \text{ MHz})^2 \times (L_{\text{cable}})^2$$

F_m [Hz] Test Frequency

L_{cable} [m] Cable length

Short offset Z_s

Table 11-9 Impedance of DUT > 1.08 Ω

Test Frequency [Hz]	Measurement time mode	
	SHORT	MED, LONG
20 to 2 M	$2.5 \text{ m}\Omega \times (1 + 0.400 / V_s) \times (1 + \sqrt{(1000 / F_m)})$	$0.6 \text{ m}\Omega \times (1 + 0.400 / V_s) \times (1 + \sqrt{(1000 / F_m)})$

Table 11-10 Impedance of DUT ≤ 1.08 Ω

Test Frequency [Hz]	Measurement time mode	
	SHORT	MED, LONG
20 to 2 M	$1 \text{ m}\Omega \times (1 + 1 / V_s) \times (1 + \sqrt{(1000 / F_m)})$	$0.2 \text{ m}\Omega \times (1 + 1 / V_s) \times (1 + \sqrt{(1000 / F_m)})$

V_s [V_{rms}] Test signal voltage

F_m [Hz] Test frequency

Effect of cable extension (Short offset)

When the cable is extended, the following value is added to Z_s (independent of the measurement time mode).

Test Frequency [Hz]	Cable length			
	0 m	1 m	2 m	4 m
20 to 1 M	0	0.25 mΩ	0.5 mΩ	1 mΩ

Test Frequency [Hz]	Cable length			
	0 m	1 m	2 m	4 m
1 M to 2 M	0	1 mΩ	2 mΩ	4 mΩ

Open offset Yo

Table 11-11 Test signal voltage ≤ 2.0 Vrms

Test Frequency [Hz]	Measurement time mode	
	SHORT	MED, LONG
20 to 100 k	$2 \text{ nS} \times (1 + 0.100 / V_s) \times (1 + \sqrt{(100 / F_m)})$	$0.5 \text{ nS} \times (1 + 0.100 / V_s) \times (1 + \sqrt{(100 / F_m)})$
100 k to 1 M	$20 \text{ nS} \times (1 + 0.100 / V_s)$	$5 \text{ nS} \times (1 + 0.100 / V_s)$
1 M to 2 M	$40 \text{ nS} \times (1 + 0.100 / V_s)$	$10 \text{ nS} \times (1 + 0.100 / V_s)$

Table 11-12 Test signal voltage > 2.0 Vrms

Test Frequency [Hz]	Measurement time mode	
	SHORT	MED, LONG
20 to 100 k	$2 \text{ nS} \times (1 + 2 / V_s) \times (1 + \sqrt{(100 / F_m)})$	$0.5 \text{ nS} \times (1 + 2 / V_s) \times (1 + \sqrt{(100 / F_m)})$
100 k to 1 M	$20 \text{ nS} \times (1 + 2 / V_s)$	$5 \text{ nS} \times (1 + 2 / V_s)$
1 M to 2 M	$40 \text{ nS} \times (1 + 2 / V_s)$	$10 \text{ nS} \times (1 + 2 / V_s)$

Vs [Vrms] Test signal voltage
Fm [Hz] Test frequency

NOTE The Open Offset may become three times greater in the ranges of 40 kHz to 70 kHz and 80 kHz to 100 kHz due to residual response.

Effect of cable length

When the cable is extended, multiply Yo by the following factor.

Test Frequency [Hz]	Cable length			
	0 m	1 m	2 m	4 m
100 to 100 k	1	$1 + 5 \times F_m / 1 \text{ MHz}$	$1 + 10 \times F_m / 1 \text{ MHz}$	$1 + 20 \times F_m / 1 \text{ MHz}$
100 k to 1 M	1	$1 + 0.5 \times F_m / 1 \text{ MHz}$	$1 + 1 \times F_m / 1 \text{ MHz}$	$1 + 2 \times F_m / 1 \text{ MHz}$
1 M to 2 M	1	$1 + 1 \times F_m / 1 \text{ MHz}$	$1 + 2 \times F_m / 1 \text{ MHz}$	$1 + 4 \times F_m / 1 \text{ MHz}$

Specifications and Supplemental Information
Basic Specifications

Fm [Hz] Test frequency

Temperature factor Kt

The temperature factor Kt is given below.

Temperature [°C]	Kt
0 to 18	4
18 to 28	1
28 to 55	4

Calibration accuracy A_{cal}

Calibration accuracy A_{cal} is given below.

For the impedance of a DUT on the boundary line, apply the smaller value.

Table 11-13 Impedance range = 0.1, 1, 10 Ω

	Test Frequency [Hz]					
	20 to 1 k	1 k to 10 k	10 k to 100 k	100 k to 300 k	300 k to 1 M	1 M to 2 M
Z [%]	0.03	0.05	0.05	$0.05 + 5 \times 10^{-5}F_m$	$0.05 + 5 \times 10^{-5}F_m$	$0.1 + 1 \times 10^{-4}F_m$
θ [radian]	1×10^{-4}	2×10^{-4}	3×10^{-4}	$3 \times 10^{-4} + 2 \times 10^{-7}F_m$	$3 \times 10^{-4} + 2 \times 10^{-7}F_m$	$6 \times 10^{-4} + 4 \times 10^{-7}F_m$

Table 11-14 Impedance range = 100 Ω

	Test Frequency [Hz]					
	20 to 1 k	1 k to 10 k	10 k to 100 k	100 k to 300 k	300 k to 1 M	1 M to 2 M
Z [%]	0.03	0.05	0.05	$0.05 + 5 \times 10^{-5}F_m$	$0.05 + 5 \times 10^{-5}F_m$	$0.1 + 1 \times 10^{-4}F_m$
θ [radian]	1×10^{-4}	2×10^{-4}	3×10^{-4}	3×10^{-4}	3×10^{-4}	6×10^{-4}

Table 11-15 Impedance range = 300, 1 k Ω

	Test Frequency [Hz]					
	20 to 1 k	1 k to 10 k	10 k to 100 k	100 k to 300 k	300 k to 1 M	1 M to 2 M
Z [%]	0.03	0.03	0.05	0.05	0.05	0.1
θ [radian]	1×10^{-4}	1×10^{-4}	3×10^{-4}	3×10^{-4}	3×10^{-4}	6×10^{-4}

Specifications and Supplemental Information
Basic Specifications

Table 11-16 Impedance range = 3 k, 10 kΩ

	Test Frequency [Hz]					
	20 to 1 k	1 k to 10 k	10 k to 100 k	100 k to 300 k	300 k to 1 M	1 M to 2 M
Z [%]	0.03 + $1 \times 10^{-4}F_m$	0.03 + $1 \times 10^{-4}F_m$	0.03 + $1 \times 10^{-4}F_m$	0.03 + $1 \times 10^{-4}F_m$	0.03 + $1 \times 10^{-4}F_m$	0.06 + $2 \times 10^{-4}F_m$
θ [radian]	$(100 + 2.5F_m) \times 10^{-6}$	$(100 + 2.5F_m) \times 10^{-6}$	$(100 + 2.5F_m) \times 10^{-6}$	$(100 + 2.5F_m) \times 10^{-6}$	$(100 + 2.5F_m) \times 10^{-6}$	$(200 + 5F_m) \times 10^{-6}$

Table 11-17 Impedance range = 30 k, 100 kΩ

	Test Frequency [Hz]					
	20 to 1 k	1 k to 10 k	10 k to 100 k	100 k to 300 k	300 k to 1 M	1 M to 2 M
Z [%]	0.03 + $1 \times 10^{-3}F_m$	0.03 + $1 \times 10^{-3}F_m$	0.03 + $1 \times 10^{-3}F_m$	0.03 + $1 \times 10^{-3}F_m$	0.03 + $1 \times 10^{-4}F_m$	0.06 + $2 \times 10^{-4}F_m$
θ [radian]	$(100 + 20F_m) \times 10^{-6}$	$(100 + 20F_m) \times 10^{-6}$	$(100 + 20F_m) \times 10^{-6}$	$(100 + 20F_m) \times 10^{-6}$	$(100 + 2.5F_m) \times 10^{-6}$	$(200 + 5F_m) \times 10^{-6}$

Fm[kHz]

Test Frequency

Measurement accuracy

An example of the calculation result for the impedance measurement accuracy is shown below. This example is the calculation result of the absolute measurement accuracy.

Figure 11-1

Impedance measurement accuracy (Test signal voltage = 1 Vrms, Cable length = 0 m, Measurement time mode = MED)

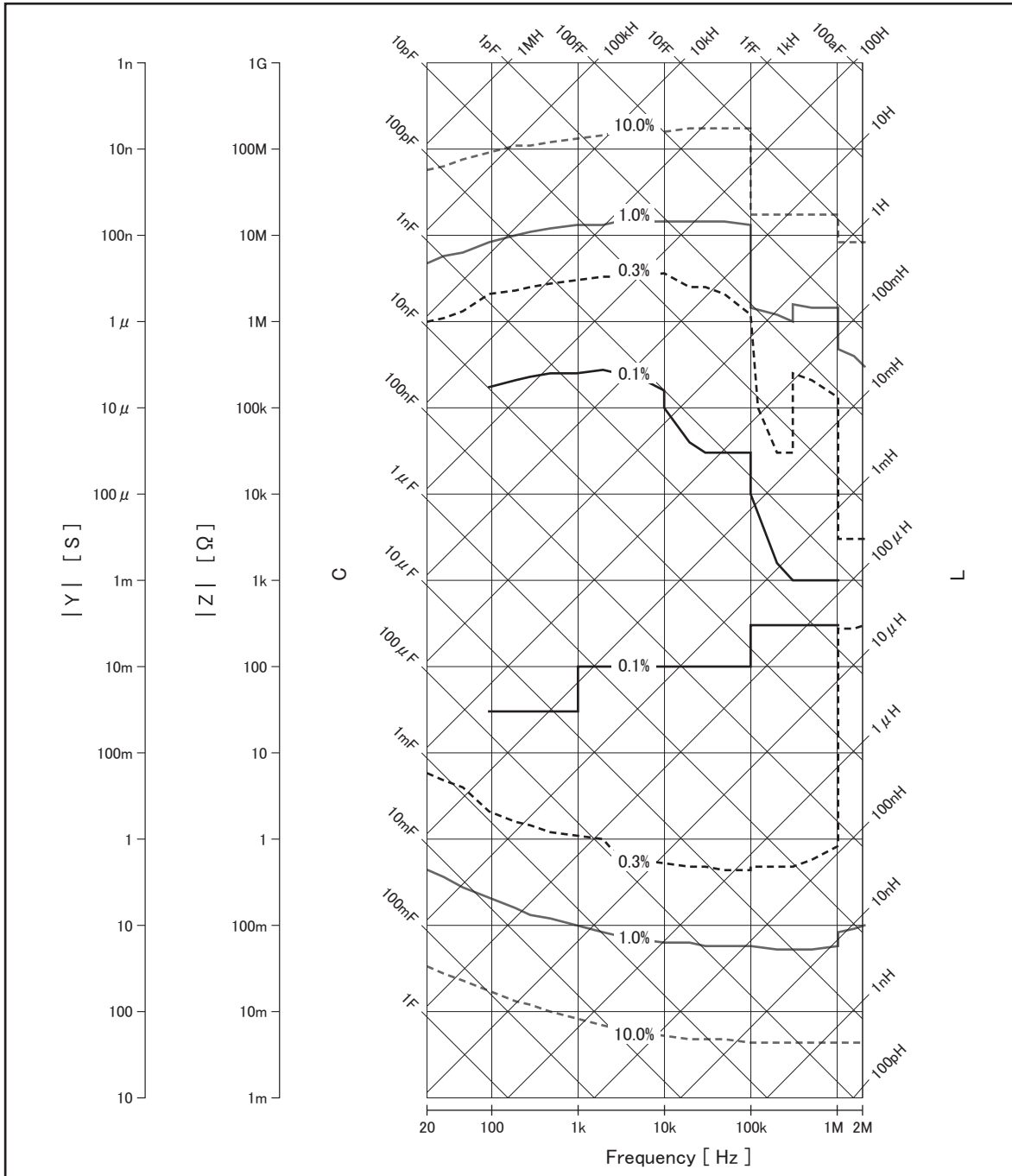

e4980auj1164

Correction function

The E4980A provides three types of correction functions: OPEN correction, SHORT correction, and LOAD correction.

Type of correction	Description
OPEN correction	Compensates errors caused by the stray admittance (C, G) of the test fixture.
SHORT correction	Compensates errors caused by the residual impedance (L, R) of the test fixture.
LOAD correction	Compensates errors between the actual measured value and a known standard value under the measurement conditions desired by the user.

List sweep

Points

There is a maximum of 201 points.

First sweep parameter (primary parameter)

Test frequency, test signal voltage, test signal current, test signal voltage of DC bias signal, test signal current of DC bias signal, DC source voltage.

Second sweep parameter (secondary parameter)

None, impedance range, test frequency, test signal voltage, test signal current, test signal voltage of DC bias signal, test signal current of DC bias signal, DC source voltage.

NOTE

A parameter selected as one of the two parameters cannot be selected for the other parameter. It is not possible to set up a combination of test signal voltage and test signal current or one of test signal voltage of DC bias signal and test signal current of DC bias.

The secondary parameter can be set only with SCPI commands.

Trigger mode

- Sequential mode

When the E4980A is triggered once, the device is measured at all sweep points.
/EOM/INDEX is output only once.

- Step mode

The sweep point is incremented each time the E4980A is triggered.

/EOM/INDEX is output at each point, but the result of the comparator function of the list sweep is available only after the last /EOM is output.

Comparator function of list sweep

The comparator function enables you to set one pair of lower and upper limits for each measurement point.

You can select from: Judge with the first sweep parameter/Judge with the second parameter/Not used for each pair of limits.

Time stamp function

In the sequential mode, it is possible to record the measurement starting time at each measurement point by defining the time when the E4980A detects a trigger as 0. Then, you can obtain it later with the SCPI command.

Comparator function

Bin sort

The primary parameter can be sorted into 9 BINs, OUT_OF_BINS, AUX_BIN, and LOW_C_REJECT. The secondary parameter can be sorted into HIGH, IN, and LOW.

The sequential mode or tolerance mode can be selected as the sorting mode.

Limit setup

Absolute value, deviation value, and % deviation value can be used for setup.

BIN count

Countable from 0 to 999999.

DC bias signal

Test signal voltage

Range	0 V to +2 V
Resolution	0 V / 1.5 V / 2 V only
Accuracy	0.1% + 2 mV (23°C ± 5°C) (0.1% + 2 mV) × 4 (0°C to 18°C or 28°C to 55 °C)

Output impedance

100 Ω (nominal)

Measurement assistance functions

Data buffer function

Up to 201 measurement results can be read out in batch.

Save/Recall function

- Up to 10 setup conditions can be written to/read from the built-in non-volatile memory.
- Up to 10 setup conditions can be written to/read from the USB memory.
- Auto recall function can be performed when the setting conditions are written to Register 10 of the USB memory.

Key lock function

The front panel keys can be locked.

GPIB

24-pin D-Sub (Type D-24), female; complies with IEEE488.1, 2 and SCPI.

USB host port

Universal serial bus jack, type-A (4 contact positions, contact 1 is on your left); female; for connection to USB memory device only.

NOTE

The following USB memory can be used.

Complies with USB 1.1; mass storage class, FAT16/FAT32 format; maximum consumption current is below 500 mA.

Use the prepared USB memory device exclusively for the E4980A; otherwise, other previously saved data may be cleared. If you use a USB memory other than the recommended device, data may not be saved or recalled normally.

Agilent Technologies will NOT be responsible for Data loss in the USB memory caused by using the E4980A.

USB interface port

Universal serial bus jack, type mini-B (4 contact positions); complies with USBTMC-USB488 and USB 2.0; female; for connection to the external controller.

USBTMC: Abbreviation for USB Test & Measurement Class

LAN

10/100BaseT Ethernet, 8 pins; two speed options

Compliant with LXI standard (LAN eXtensions for Instrumentation): Version 1.1, Class C

Options

The following options are available for the E4980A.

NOTE

Option xxx is described as E4980A-xxx in the order information.

Option 001 (Power and DC Bias enhancement)

Increases test signal voltage and adds the variable DC bias voltage function.

Measurement parameters

The following parameters can be used.

- Lp-Rdc
- Ls-Rdc
- Vdc-Idc

where

Rdc: Direct-current resistance (DCR)

Vdc: Direct-current voltage

Idc: Direct-current electricity

Test signal

Signal level

Table 11-18 Test signal voltage

Range	0 Vrms to 20 Vrms (Test Frequency \leq 1 MHz) 0 Vrms to 15 Vrms (Test Frequency $>$ 1 MHz)
Resolution	100 μ Vrms (0 Vrms to 0.2 Vrms) 200 μ Vrms (0.2 Vrms to 0.5 Vrms) 500 μ Vrms (0.5 Vrms to 1 Vrms) 1 mVrms (1 Vrms to 2 Vrms) 2 mVrms (2 Vrms to 5 Vrms) 5 mVrms (5 Vrms to 10 Vrms) 10 mVrms (10 Vrms to 20 Vrms)

Table 11-18 Test signal voltage

Setup accuracy	normal	$\pm(10\% + 1 \text{ mVrms})$ (All Test Frequency, Test signal voltage $\leq 2 \text{ Vrms}$) (Test Frequency $\leq 1 \text{ MHz}$: spec., Test Frequency $> 1 \text{ MHz}$: typ.)
		$\pm(10\% + 10 \text{ mVrms})$ (Test Frequency $\leq 300 \text{ kHz}$, Test signal voltage $> 2 \text{ Vrms}$) (spec.)
		$\pm(15\% + 20 \text{ mVrms})$ (Test Frequency $> 300 \text{ kHz}$, Test signal voltage $> 2 \text{ Vrms}$) (Test Frequency $\leq 1 \text{ MHz}$: spec., Test Frequency $> 1 \text{ MHz}$: typ.)
	constant ^{*1}	$\pm(6\% + 1 \text{ mVrms})$ (All Test Frequency, Test signal voltage $\leq 2 \text{ Vrms}$) (Test Frequency $\leq 1 \text{ MHz}$: spec., Test Frequency $> 1 \text{ MHz}$: typ.)
		$\pm(6\% + 10 \text{ mVrms})$ (Test Frequency $\leq 300 \text{ kHz}$, Test signal voltage $> 2 \text{ Vrms}$) (spec.)
		$\pm(12\% + 20 \text{ mVrms})$ (Test Frequency $> 300 \text{ kHz}$, Test signal voltage $> 2 \text{ Vrms}$) (Test Frequency $\leq 1 \text{ MHz}$: spec., Test Frequency $> 1 \text{ MHz}$: typ.)

*1. When auto level control function is on.

Table 11-19 Test signal current

Range	0 Arms to 100 mArms	
Resolution	1 μ Arms (0 Arms to 2 mArms) 2 μ Arms (2 mArms to 5 mArms) 5 μ Arms (5 mArms to 10 mArms) 10 μ Arms (10 mArms to 20 mArms) 20 μ Arms (20 mArms to 50 mArms) 50 μ Arms (50 mArms to 100 mArms)	
Setup accuracy	normal	$\pm(10\% + 10 \mu\text{Arms})$ (All Test Frequency, Test signal current $\leq 20 \text{ mArms}$) (Test Frequency $\leq 1 \text{ MHz}$: spec., Test Frequency $> 1 \text{ MHz}$: typ.)
		$\pm(10\% + 100 \mu\text{Arms})$ (Test Frequency $\leq 300 \text{ kHz}$, Test signal current $> 20 \text{ mArms}$) (spec.)
		$\pm(15\% + 200 \mu\text{Arms})$ (Test Frequency $> 300 \text{ kHz}$, Test signal current $> 20 \text{ mArms}$) (Test Frequency $\leq 1 \text{ MHz}$: spec., Test Frequency $> 1 \text{ MHz}$: typ.)
	constant ^{*1}	$\pm(6\% + 10 \mu\text{Arms})$ (All Test Frequency, Test signal current $\leq 20 \text{ mArms}$) (Test Frequency $\leq 1 \text{ MHz}$: spec., Test Frequency $> 1 \text{ MHz}$: typ.)
		$\pm(6\% + 100 \mu\text{Arms})$ (Test Frequency $\leq 300 \text{ kHz}$, Test signal current $> 20 \text{ mArms}$) (spec.)
		$\pm(12\% + 200 \mu\text{Arms})$ (Test Frequency $> 300 \text{ kHz}$, Test signal current $> 20 \text{ mArms}$) (Test Frequency $\leq 1 \text{ MHz}$: spec., Test Frequency $> 1 \text{ MHz}$: typ.)

*1. When auto level control function is on.

Test signal level monitor function

- Test signal voltage and test signal current can be monitored.

- Level monitor accuracy:

Table 11-20 Test signal voltage level monitor accuracy (Vac)

Test signal voltage ^{*1}	Test Frequency	Specification
5 mVrms to 2 Vrms	≤ 1 MHz	± (3% of reading value + 0.5 mVrms)
	> 1 MHz	± (6% of reading value + 1 mVrms)
> 2 Vrms	≤ 300 kHz	± (3% of reading value + 5 mVrms)
	> 300 kHz	± (6% of reading value + 10 mVrms) ^{*2}

*1. This is not an output value but a displayed test signal level.

*2. Typ. when test frequency > 1 MHz and test signal voltage > 10 Vrms.

Table 11-21 Test signal current level monitor accuracy (Iac)

Test signal current ^{*1}	Test Frequency	Specification
50 μArms to 20 mArms	≤ 1 MHz	± (3% of reading value + 5 μArms)
	> 1 MHz	± (6% of reading value + 10 μArms)
> 20 mArms	≤ 300 kHz	± (3% of reading value + 50 μArms)
	> 300 kHz	± (6% of reading value + 100 μArms)

*1. This is not an output value but a displayed test signal level.

DC bias signal

Test signal voltage

Range	-40 V to +40 V	
Resolution	Setup resolution: 100 μV, valid resolution 330 μV ±(0 V to 5 V) 1 mV, ± (5 V to 10 V) 2 mV, ± (10 V to 20 V) 5 mV, ± (20 V to 40 V) ^{*1}	
Accuracy ^{*2}	test signal voltage ≤ 2 Vrms	0.1% + 2 mV (23°C ± 5°C) (0.1% + 2 mV) × 4 (0°C to 18°C or 28°C to 55°C)
	test signal voltage > 2 Vrms	0.1% + 4 mV (23°C ± 5°C) (0.1% + 4 mV) × 4 (0°C to 18°C or 28°C to 55°C)

*1. When the range is set to FIX, this is 5 mV, ± (0 V to 40 V).

*2. When the range is set to FIX, refer to “DC bias signal” on page 444.

Test signal current

Specifications and Supplemental Information
Options

Range	-100 mA to 100 mA
Resolution	Setup resolution: 1 μ A, valid resolution: 3.3 μ A \pm (0 A to 50 mA) 10 μ A \pm (50 mA to 100 mA)

DC bias voltage level monitor Vdc

$(0.5\% \text{ of reading value} + 60 \text{ mV}) \times Kt$

When using Vdc-Idc measurement: (spec.)

When using level monitor: (typ.)

Kt Temperature coefficient

(Refer to “Temperature factor Kt” on page 414).

DC bias current level monitor Idc

$(A [\%] \text{ of the measurement value} + B [A]) \times Kt$

When using Vdc-Idc measurement: (spec.)

When using level monitor: (typ.)

A [%] When the measurement time mode is SHORT: 2%
When the measurement time mode is MED or LONG: 1%

B [A] given below

Kt Temperature coefficient

(Refer to “Temperature factor Kt” on page 414).

When the measurement mode is SHORT, double the following values.

Table 11-22

Test signal voltage ≤ 0.2 Vrms [measurement time mode = MED, LONG]

DC bias current range	Impedance Range [Ω]				
	< 100	100	300, 1k	3k, 10k	30k, 100k
20 μ A	150 μ A	30 μ A	3 μ A	300 nA	45 nA
200 μ A	150 μ A	30 μ A	3 μ A	300 nA	300 nA
2 mA	150 μ A	30 μ A	3 μ A	3 μ A	3 μ A
20 mA	150 μ A	30 μ A	30 μ A	30 μ A	30 μ A
100 mA	150 μ A	150 μ A	150 μ A	150 μ A	150 μ A

Table 11-23 **0.2 Vrms < Test signal voltage ≤ 2 Vrms [measurement time mode = MED, LONG]**

DC bias current range	Impedance Range [Ω]				
	< 100	100, 300	1k, 3k	10k, 30k	100k
20 μ A	150 μ A	30 μ A	3 μ A	300 nA	45 nA
200 μ A	150 μ A	30 μ A	3 μ A	300 nA	300 nA
2 mA	150 μ A	30 μ A	3 μ A	3 μ A	3 μ A
20 mA	150 μ A	30 μ A	30 μ A	30 μ A	30 μ A
100 mA	150 μ A	150 μ A	150 μ A	150 μ A	150 μ A

Table 11-24 **Test signal voltage > 2 Vrms [measurement time mode = MED, LONG]**

DC bias current range	Impedance Range [Ω]			
	≤ 300	1k, 3k	10k, 30k	100k
20 μ A	150 μ A	30 μ A	3 μ A	300 nA
200 μ A	150 μ A	30 μ A	3 μ A	300 nA
2 mA	150 μ A	30 μ A	3 μ A	3 μ A
20 mA	150 μ A	30 μ A	30 μ A	30 μ A
100 mA	150 μ A	150 μ A	150 μ A	150 μ A

Table 11-25 **Input impedance (Nominal)**

Input impedance	Conditions
0 Ω	Other than conditions below.
20 Ω	Test signal voltage ≤ 0.2 Vrms, Impedance range ≥ 3 k Ω , DC bias current range ≤ 200 μ A
	Test signal voltage ≤ 2 Vrms, Impedance range ≥ 10 k Ω , DC bias current range ≤ 200 μ A
	Test signal voltage > 2 Vrms, Impedance range = 100 k Ω , DC bias current range ≤ 200 μ A

DC source signal

Table 11-26

Test signal voltage

Range	-10 V to 10 V
Resolution	1 mV
Accuracy	0.1% + 3 mV (23°C ± 5°C) (0.1% + 3 mV) × 4 (0°C to 18°C or 28°C to 55°C)

Table 11-27

Test signal current

Range	-45 mA to +45 mA (nominal)
-------	----------------------------

Output impedance

100 Ω (nominal)

DC resistance (Rdc) accuracy

Absolute measurement accuracy Aa

Absolute measurement accuracy Aa is given as

Equation 11-16 $Aa = Ae + Acal$

- Aa Absolute accuracy (% of reading value)
- Ae Relative accuracy (% of reading value)
- Acal Calibration accuracy

Relative measurement accuracy Ae

Relative measurement accuracy Ae is given as

Equation 11-17 $Ae = [Ab + (Rs/|Rm| + Go \times |Rm|) \times 100] \times Kt$

- Rm Measurement value
- Ab Basic accuracy
- Rs Short offset [Ω]
- Go Open offset [S]
- Kt Temperature coefficient

Calibration accuracy Acal

Calibration accuracy Acal is 0.03%.

Basic accuracy Ab

Basic accuracy Ab is given below.

Measurement time mode	Test signal voltage	
	$\leq 2 \text{ Vrms}$	$> 2 \text{ Vrms}$
SHORT	1.00%	2.00%
MED	0.30%	0.60%

Open offset Go

Open offset Go is given below.

Measurement time mode	Test signal voltage	
	$\leq 2 \text{ Vrms}$	$> 2 \text{ Vrms}$
SHORT	50 nS	500 nS
MED	10 nS	100 nS

Short offset Rs

Specifications and Supplemental Information
Options

Short offset R_s is given below.

Measurement time mode	Test signal voltage	
	$\leq 2 \text{ Vrms}$	$> 2 \text{ Vrms}$
SHORT	25 m Ω	250 m Ω
MED	5 m Ω	50 m Ω

Effect from cable length (Short offset)

The following value is added to R_s when the cable is extended.

Cable length		
1 m	2 m	4 m
0.25 m Ω	0.5 m Ω	1 m Ω

Temperature coefficient K_t

Temperature coefficient K_t is given below.

Temperature [$^{\circ}\text{C}$]	K_t
0 to 18	4
18 to 28	1
28 to 55	4

Other options

Option 002 (Bias current interface)

Adds a digital interface to allow the E4980A to control the 42841A's bias current source.

Option 005 (Entry model)

Low-priced option that requires a longer measurement time. The level of measurement accuracy is the same as the standard.

Option 007 (Standard model)

Upgrades the entry model to the standard.

NOTE

Option 007 can be installed only in an E4980A device with option 005.

Option 201 (Handler interface)

Adds handler interface.

Option 301 (Scanner interface)

Adds scanner interface.

Option 710 (No interface)

An option with no interface.

Up to 2 interface options can be installed in the interface connector on the rear panel.

When no interface is installed, two of the option 710 are installed. When one interface is installed, the option number of its interface and one option 710 are installed.

General specifications

Power source

Voltage	90 VAC to 264 VAC
Frequency	47 Hz to 63 Hz
Power consumption	Max. 150 VA

Operating environment

Temperature	0°C to 55°C
Humidity (≤ 40°C, no condensation)	15% to 85% RH
Altitude	0 m to 2000 m

Storage environment

Temperature	-20°C to 70°C
Humidity (≤ 60°C, no condensation)	0% to 90% RH
Altitude	0 m to 4572 m

Outer dimensions

375 (width) × 105 (height) × 390 (depth) mm (nominal)

Figure 11-2

Dimensions (front view, with handle and bumper, in millimeters, nominal)

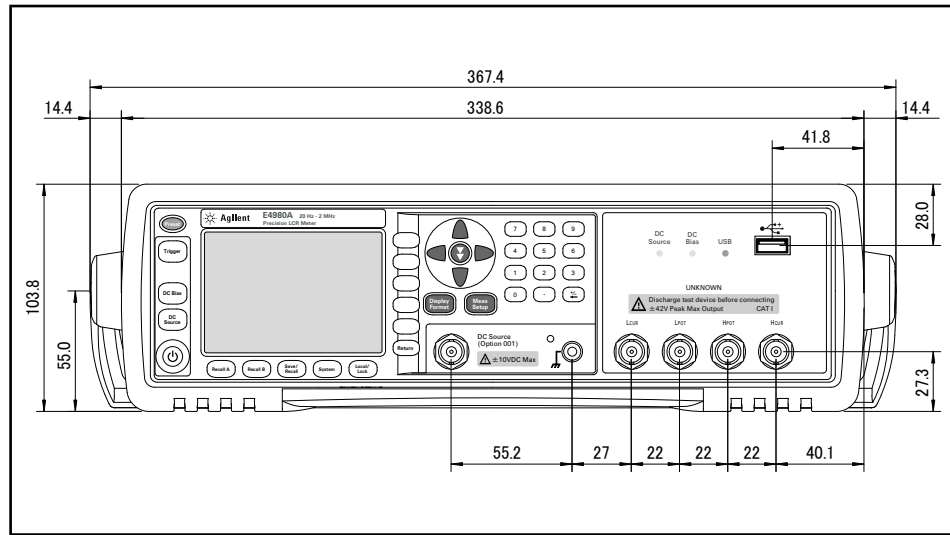

e4980auj1023

Figure 11-3

Dimensions (front view, without handle and bumper, in millimeters, nominal)

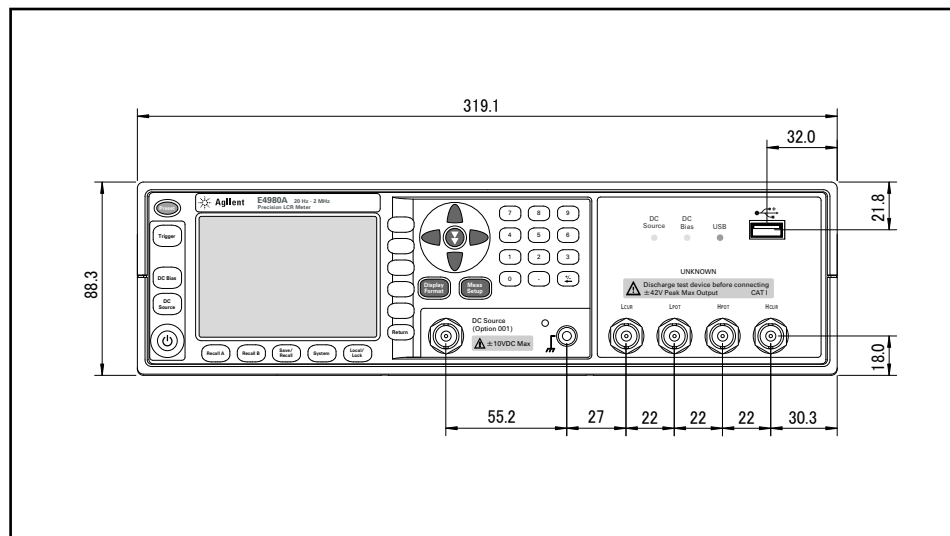

e4980auj1024

Figure 11-4 Dimensions (rear view, with handle and bumper, in millimeters, nominal)

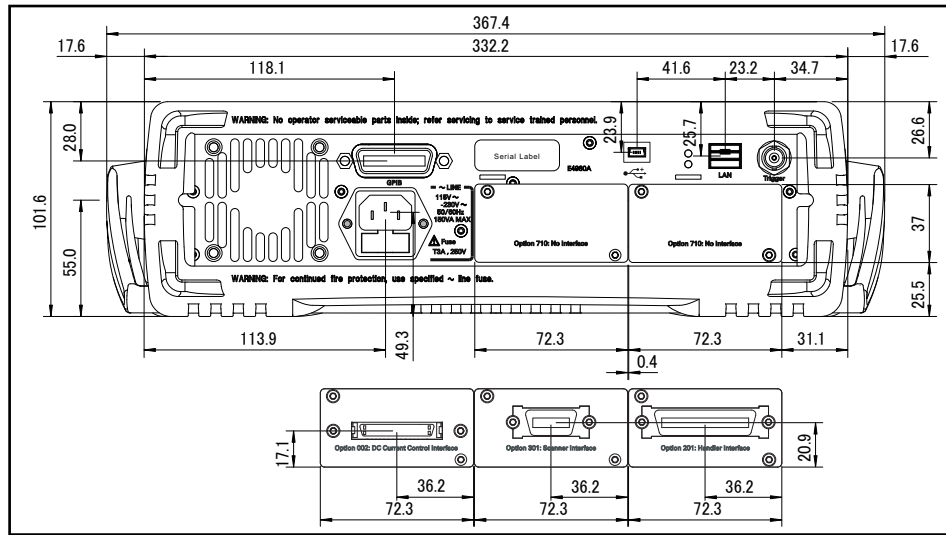

e4980auj1027

Figure 11-5 Dimensions (front view, without handle and bumper, in millimeters, nominal)

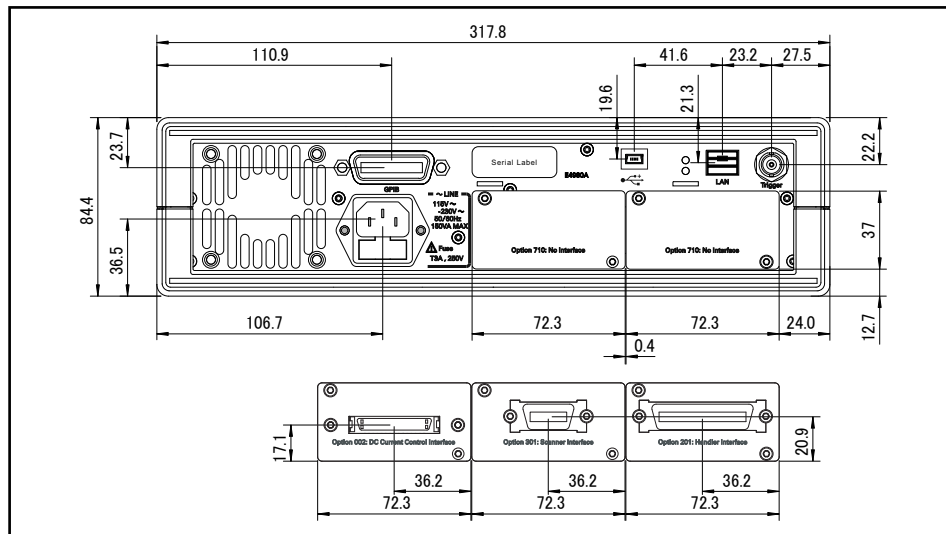

e4980auj1028

Figure 11-6

Dimensions (side view, with handle and bumper, in millimeters, nominal)

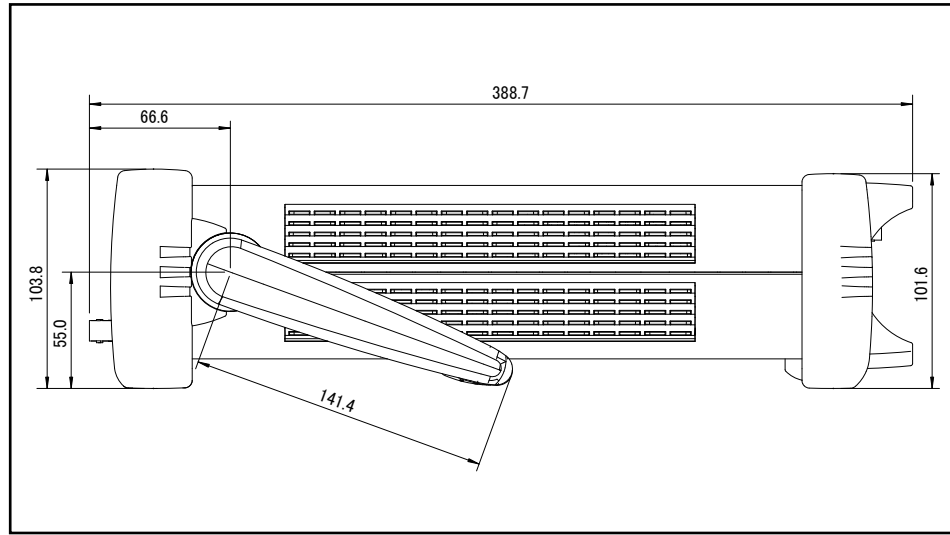

e4980auj1025

Figure 11-7

Dimensions (side view, without handle and bumper, in millimeters, nominal)

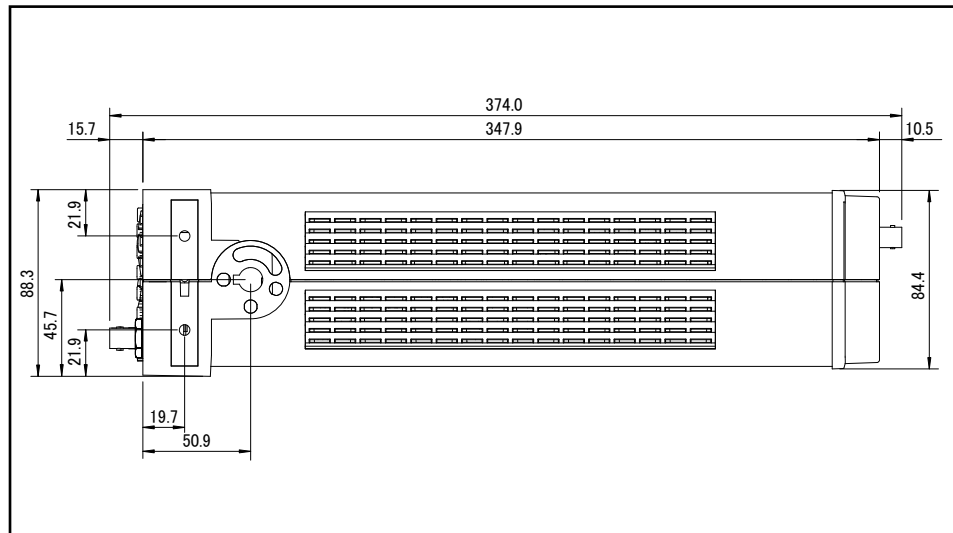

e4980auj1026

Weight

5.3 kg (nominal)

Display

LCD, 320 × 240 (pixels), RGB color

The following items can be displayed.





Measurement value, measurement conditions, limit value and judgment result of the comparator, list sweep table, and self-test message.

NOTE

Effective pixels are more than 99.99%. There may be at most 0.01% (approx. 7 pixels) missing pixels or constantly lit pixels, but this is not a defect.

EMC, Safety, and Environment

Table 11-28 EMC, Safety, and Environment

Description	Supplemental Information
EMC	
	<p>European Council Directive 89/336/EEC, 92/31/EEC, 93/68/EEC IEC 61326-1:1997 +A1:1998 +A2:2000 EN 61326-1:1997 +A1:1998 +A2:2001 CISPR 11:1997 +A1:1999 +A2:2002 EN 55011:1998 +A1:1999 +A2:2002 Group 1, Class A IEC 61000-4-2:1995 +A1:1998 +A2:2001 EN 61000-4-2:1995 +A1:1998 +A2:2001 4 kV CD / 8 kV AD IEC 61000-4-3:1995 +A1:1998 +A2:2001 EN 61000-4-3:1996 +A1:1998 +A2:2001 3 V/m, 80-1000 MHz, 80% AM IEC 61000-4-4:1995 +A1:2001 +A2:2001 EN 61000-4-4:1995 +A1:2001 +A2:2001 1 kV power / 0.5 kV Signal IEC 61000-4-5:1995 +A1:2001 EN 61000-4-5:1995 +A1:2001 0.5 kV Normal / 1 kV Common IEC 61000-4-6:1996 +A1:2001 EN 61000-4-6:1996 +A1:2001 3 V, 0.15-80 MHz, 80% AM IEC 61000-4-11:1994 +A1:2001 EN 61000-4-11:1994 +A1:2001 100% 1cycle</p>
<p>ICES/NMB-001</p>	<p>This ISM device complies with Canadian ICES-001:1998. Cet appareil ISM est conforme a la norme NMB-001 du Canada.</p>
	<p>AS/NZS 2064.1 Group 1, Class A</p>
Safety	
	<p>European Council Directive 73/23/EEC, 93/68/EEC IEC 61010-1:2001/EN 61010-1:2001 Measurement Category I, Pollution Degree 2, Indoor Use IEC60825-1:1994 Class 1 LED</p>
	<p>CAN/CSA C22.2 61010-1-04 Measurement Category I, Pollution Degree 2, Indoor Use</p>
Environment	
	<p>This product complies with the WEEE Directive (2002/96/EC) marking requirements. The affixed label indicates that you must not discard this electrical/electronic product in domestic household waste.</p> <p>Product Category: With reference to the equipment types in the WEEE Directive Annex I, this product is classed as a “Monitoring and Control instrumentation” product.</p>

Supplemental Information

Settling time

The test frequency setting time is shown below.

Table 11-29

Test frequency setting time

Test frequency setting time	Test Frequency (Fm)
5 ms	$F_m \geq 1 \text{ kHz}$
12 ms	$1 \text{ kHz} > F_m \geq 250 \text{ Hz}$
22 ms	$250 \text{ Hz} > F_m \geq 60 \text{ Hz}$
42 ms	$60 \text{ Hz} > F_m$

The signal voltage setting time is given below.

Table 11-30

Test signal voltage setting time

Test signal voltage setting time	Test Frequency (Fm)
11 ms	$F_m \geq 1 \text{ kHz}$
18 ms	$1 \text{ kHz} > F_m \geq 250 \text{ Hz}$
26 ms	$250 \text{ Hz} > F_m \geq 60 \text{ Hz}$
48 ms	$60 \text{ Hz} > F_m$

Switching of the impedance range is as follows.

$\leq 5 \text{ ms/ range switching}$

Measurement circuit protection

The maximum discharge withstand voltage, where the internal circuit remains protected if a charged capacitor is connected to the UNKNOWN terminal, is given below.

NOTE

Discharge capacitors before connecting them to the UNKNOWN terminal or a test fixture.

Table 11-31

Maximum discharge withstand voltage

Maximum discharge withstand voltage	Range of capacitance value C of DUT
1000 V	$C < 2 \mu\text{F}$
$\sqrt{2/C} \text{ V}$	$2 \mu\text{F} \leq C$

Figure 11-8

Maximum discharge withstand voltage

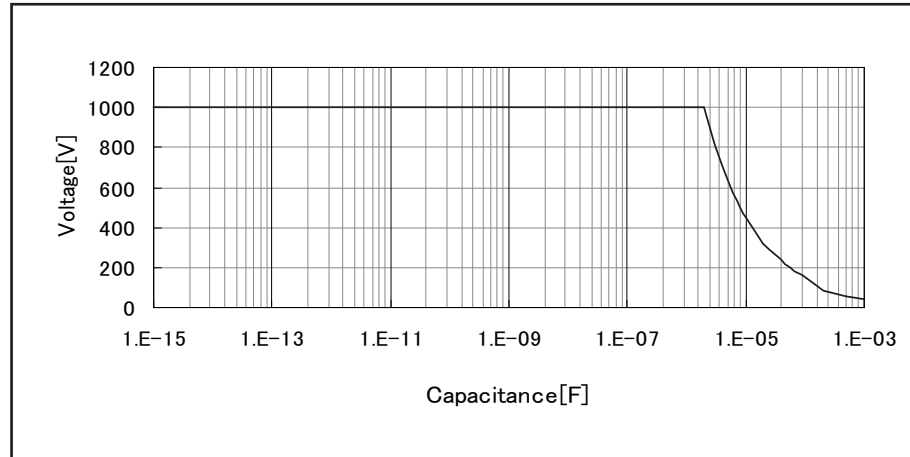

e4980auj1036

Measurement time

Definition

This is the time between the trigger and the end of measurement (EOM) output on the handler interface.

Conditions

Table 11-32 shows the measurement time when the following conditions are satisfied.

- Normal impedance measurement other than Ls-Rdc, Lp-Rdc, Vdc-Idc
- Impedance range mode: hold range mode
- DC bias voltage level monitor: OFF
- DC bias current level monitor: OFF
- Trigger delay: 0 s
- Step delay: 0 s
- Calibration data: OFF
- Display mode: blank
- Auto Level Control: OFF
- Averaging: 1

Measurement time

Table 11-32

Measurement time [ms](DC bias: OFF)

	Measure-ment time mode	Test frequency						
		20 Hz	100 Hz	1 kHz	10 kHz	100 kHz	1 MHz	2 MHz
1	LONG	480	300	240	230	220	220	220

Table 11-32 Measurement time [ms](DC bias: OFF)

	Measure- ment time mode	Test frequency						
		20 Hz	100 Hz	1 kHz	10 kHz	100 kHz	1 MHz	2 MHz
2	MED	380	180	110	92	89	88	88
3	SHORT	330	100	20	7.7	5.7	5.6	5.6

Figure 11-9 Measurement time (DC bias: OFF)

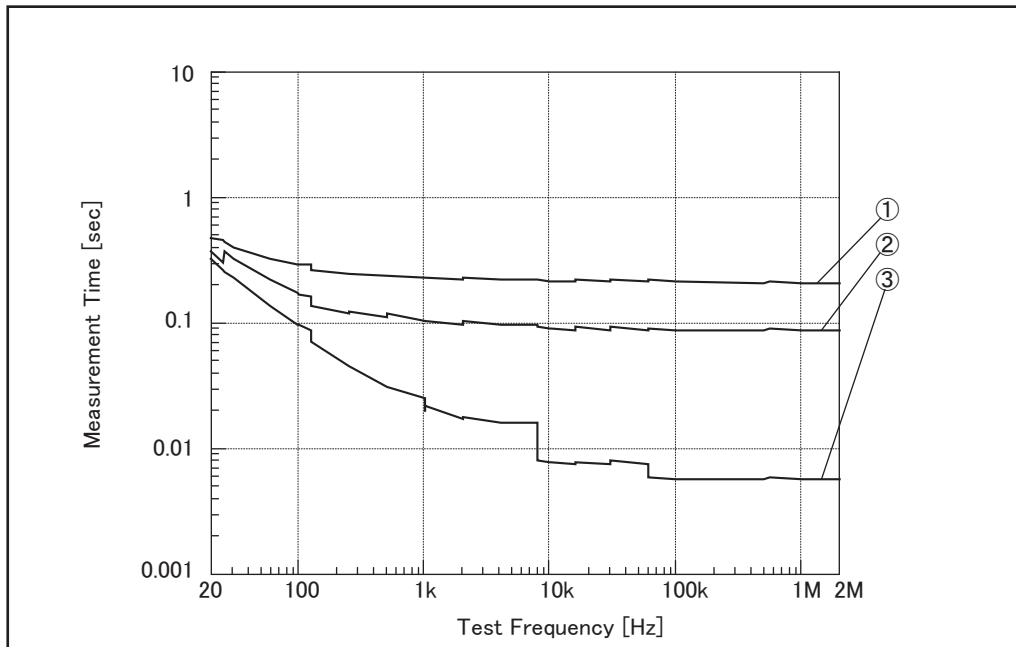

e4980aue1162

Measurement time when option 005 is installed.

Measurement times with option 005 installed are shown below.

Table 11-33 Measurement time when option 005 is installed [ms] (DC bias: OFF, typical)

	Measure- ment time mode	Test frequency						
		20 Hz	100 Hz	1 kHz	10 kHz	100 kHz	1 MHz	2 MHz
1	LONG	1190	650	590	580	570	570	570
2	MED	1150	380	200	180	180	180	180
3	SHORT	1040	240	37	25	23	23	23

Figure 11-10 Measurement time (DC bias: OFF, option 005, typical)

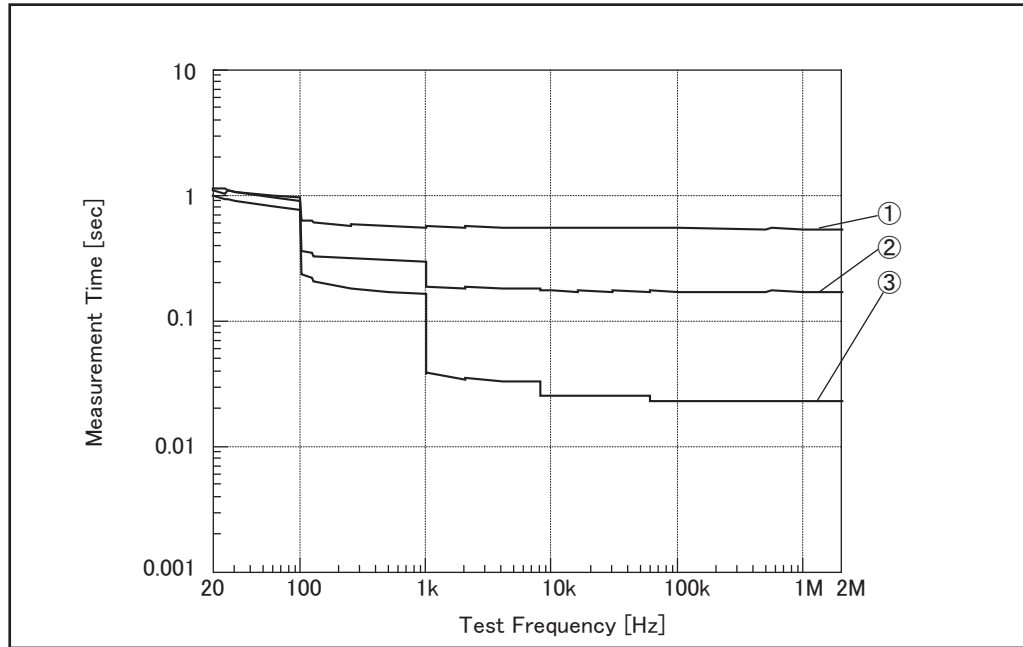

e4980aue1163

When DC bias is ON, the following time is added.

Table 11-34 Additional time when DC bias is ON [ms]

Test frequency						
20 Hz	100 Hz	1 kHz	10 kHz	100 kHz	1 MHz	2 MHz
30	30	10	13	2	0.5	0.5

When the number of averaging increases, the measurement time is given as

Equation 11-18 $MeasTime + (Ave - 1) \times AveTime$

MeasTime Measurement time calculated based on
 Table 11-32 and Table 11-34

Ave Number of averaging

AveTime Refer to Table 11-35

Table 11-35 Additional time per averaging [ms]

Measurement time mode	Test frequency						
	20 Hz	100 Hz	1 kHz	10 kHz	100 kHz	1 MHz	2 MHz
SHORT	51	11	2.4	2.4	2.3	2.2	2.2

Table 11-35 Additional time per averaging [ms]

Measurement time mode	Test frequency						
	20 Hz	100 Hz	1 kHz	10 kHz	100 kHz	1 MHz	2 MHz
MED	110	84	88	87	85	84	84
LONG	210	210	220	220	220	210	210

Display time

Except for the case of the DISPLAY BLANK page, the time required to update the display on each page (display time) is as follows. When a screen is changed, drawing time and switching time are added. The measurement display is updated about every 100 ms.

Table 11-36 Display time

Item	When Vdc, Idc monitor is OFF	When Vdc, Idc monitor is ON
MEAS DISPLAY page drawing time	10 ms	13 ms
MEAS DISPLAY page (large) drawing time	10 ms	13 ms
BIN No. DISPLAY page drawing time	10 ms	13 ms
BIN COUNT DISPLAY page drawing time	10 ms	13 ms
LIST SWEEP DISPLAY page drawing time	40 ms	-
Measurement display switching time	35 ms	-

Measurement data transfer time

Table 11-37 shows the measurement transfer time under the following conditions. The measurement transfer time varies with the measurement conditions and computers used.

Host computer: DELL OPTIPLEX GX260 Pentium 4 2.6 GHz
 Display: ON
 Impedance range mode: AUTO (overload has not been generated)
 OPEN/SHORT/LOAD correction: OFF
 Test signal voltage monitor: OFF

Table 11-37 Measurement data transfer time [ms]

Interface	Data transfer format	using :FETC? command (one point measurement)		using data buffer memory (list sweep measurement)			
		Comparator ON	Comparator OFF	10 points	51 points	128 points	201 points
GPIB	ASCII	2	2	4	13	28	43
	ASCII Long	2	2	5	15	34	53
	Binary	2	2	4	10	21	32
USB	ASCII	2	2	3	8	16	23
	ASCII Long	2	2	4	9	19	28
	Binary	2	2	3	5	9	13
LAN	ASCII	3	4	5	12	24	36
	ASCII Long	3	3	5	13	29	44
	Binary	3	3	5	9	18	26

DC bias test signal current (1.5 V / 2.0 V)

Output current: Max. 20 mA

Option 001 (Power and DC Bias enhancement)

DC bias voltage

DC bias voltage applied to DUT is given as

Equation 11-19 $V_{dut} = V_b - 100 \times I_b$

V_{dut} [V] DC bias voltage

Specifications and Supplemental Information
Supplemental Information

Vb [V] DC bias setting voltage

Ib [A] DC bias current

DC bias current

DC bias current applied to DUT is given as

Equation 11-20 $I_{dut} = Vb / (100 + Rdc)$

Idut [A] DC bias current

Vb [V] DC bias setting voltage

Rdc [W] DUT's DC resistance

Maximum DC bias current

Maximum DC bias current when the normal measurement can be performed is as follows.

Impedance range [Ω]	DC Bias current isolation		
	ON	OFF	
		Test signal voltage ≤ 2 Vrms	Test signal voltage > 2 Vrms
0.1	Auto range mode: 100 mA Hold range mode: its values for the range. *1	20 mA	100 mA
1		20 mA	100 mA
10		20 mA	100 mA
100		20 mA	100 mA
300		2 mA	100 mA
1 k		2 mA	20 mA
3 k		200 μA	20 mA
10 k		200 μA	2 mA
30 k		20 μA	2 mA
100 k		20 μA	200 μA

*1. When impedance range = 100 Ω, test signal voltage ≤ 2 Vrms, and DC bias current isolation function is on, the maximum DC bias current is 100 mA.

When DC bias is applied to DUT

When DC bias is applied to the DUT, add the following value to the absolute accuracy Ab.

Table 11-38

Only when Fm < 10 kHz and |Vdc| > 5 V

SHORT	MED, LONG
$0.05\% \times (100 \text{ mV} / Vs) \times (1 + \sqrt{(100 / Fm)})$	$0.01\% \times (100 \text{ mV} / Vs) \times (1 + \sqrt{(100 / Fm)})$

Fm [Hz] Test Frequency
 Vs [V] Test signal voltage

Relative measurement accuracy with bias current isolation

When DC bias Isolation is set to ON, add the following value to the open offset Yo.

Equation 11-21 $YoDCI1 \times (1 + 1/(Vs)) \times (1 + \sqrt{(500/Fm)}) + YoDCI2$

Zm [W] Impedance of DUT

Fm [Hz] Test frequency

Vs [V] Test signal voltage

Yo_DC1,2 [S] Calculate this by using the following table

Idc [A] DC bias isolation current

Table 11-39 Yo_DC1 value

DC bias current range	Measurement time mode	
	SHORT	MED, LONG
20 μA	0 S	0 S
200 μA	0.25 nS	0.05 nS
2 mA	2.5 nS	0.5 nS
20 mA	25 nS	5 nS
100 mA	250 nS	50 nS

Table 11-40 Yo_DC2 value

DC bias current range	Measurement time mode			
	≤ 100 Ω	300 Ω, 1 kΩ	3 kΩ, 10 kΩ	30 kΩ, 100 kΩ
20 μA	0 S	0 S	0 S	0 S
200 μA	0 S	0 S	0 S	0 S
2 mA	0 S	0 S	0 S	3 nS
20 mA	0 S	0 S	30 nS	30 nS
100 mA	0 S	300 nS	300 nS	300 nS

DC bias signal

Test signal voltage level

When the DC bias range is set to FIX, the accuracy is as follows.

Accuracy	Test signal voltage level ≤ 2 Vrms	0.1 % + 16 mV (23 °C \pm 5 °C) (0.1 % + 2 mV) \times 4 (0 °C to 18 °C, or 28 °C to 55 °C)
	Test signal voltage level > 2 Vrms	0.1 % + 32 mV (23 °C \pm 5 °C) (0.1 % + 4 mV) \times 4 (0 °C to 18 °C, or 28 °C to 55 °C)

DC bias settling time

When DC bias is set to ON, add the following value to the settling time.

Table 11-41 DC bias settling time

	Bias	Settling time
1	Standard	Capacitance of DUT \times 100 \times $\log_e (2 / 1.8m) + 3m$
2	Option 001	Capacitance of DUT \times 100 \times $\log_e (40 / 1.8m) + 3m$

Figure 11-11 DC bias settling time

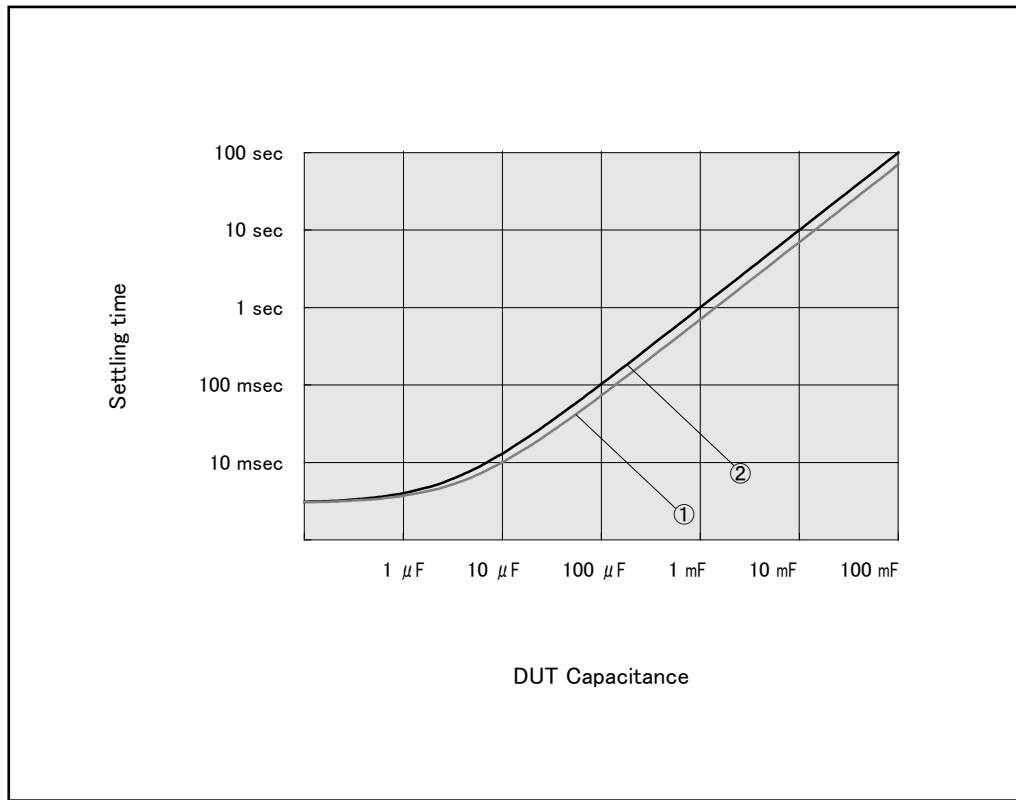

e4980aue1160

12 Precautions for Use and Daily Checks

This chapter describes precautions to take when using the E4980A and explains how to perform regular maintenance on the device.

Precautions for Use

This section describes the precautions to take in using the E4980A.

Avoiding improper input from the front panel (key lock function)

When you do not need to operate the keys on the front panel, you can disable entry from the front panel keys (key lock function) to avoid improper input caused by touching the front panel keys accidentally.

The ON/OFF state of the key lock function is indicated by whether **LOCK** is displayed in the status display area. When **LOCK** is displayed, as indicated by 1 in Figure 12-1, the function is ON.

Figure 12-1

ON/OFF display of the key lock function (when ON)

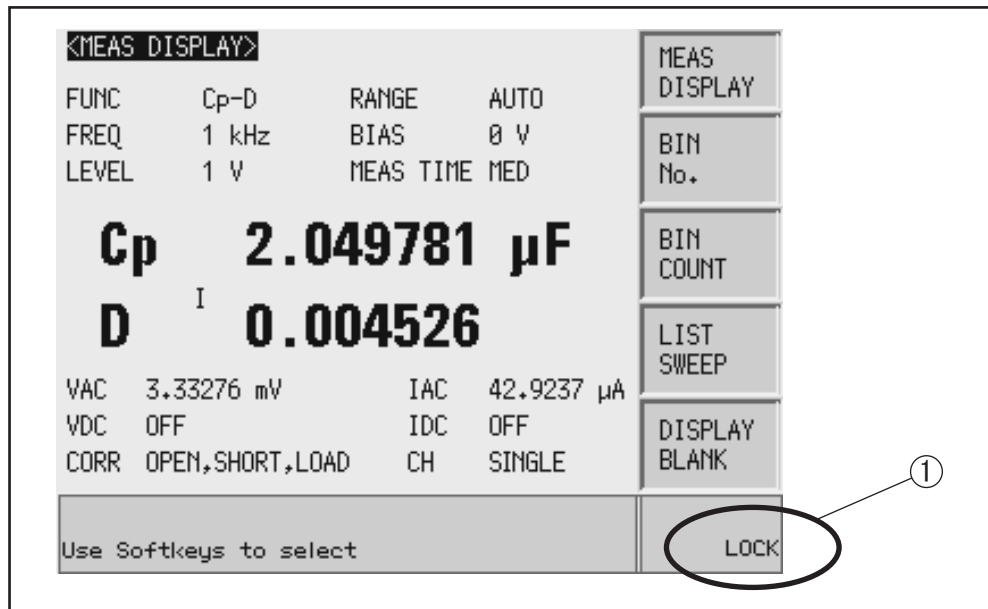

e4980auj1039

Setup procedure

- Step 1.** Press the [Local/Lock] key on the front panel.
- Step 2.** Confirm that **LOCK** is displayed in the status display area in the lower-right corner of the LCD display.

Daily Checks (Executing the self-test)

This section describes the daily checks required for the E4980A.

Self-test at power on

The E4980A provides a function that executes a self-test automatically at power-on. When the self-test detects any malfunction at power-on, an error message “Power on test failed” is displayed in the system message area. If this happens, refer to “Check Items When Trouble Occurs” on page 454.

Executing the self-test from the front panel

The self-test of the E4980A can be executed from the front panel. The steps are given below.

Self-test procedure

- Step 1.** Press [SYSTEM] - SELF TEST
- Step 2.** Use the cursor key to highlight the selection item to the right of “TEST No.” (1 in Figure 5-2)
- Step 3.** Select the number corresponding to the test that you want to perform by using the **INCR+** and **DECR-** softkeys.
- Step 4.** Press **EXECUTE - TEST START** (2 in Figure 5-2) to execute the selected test item.

Figure 12-2 Self-test screen and procedure

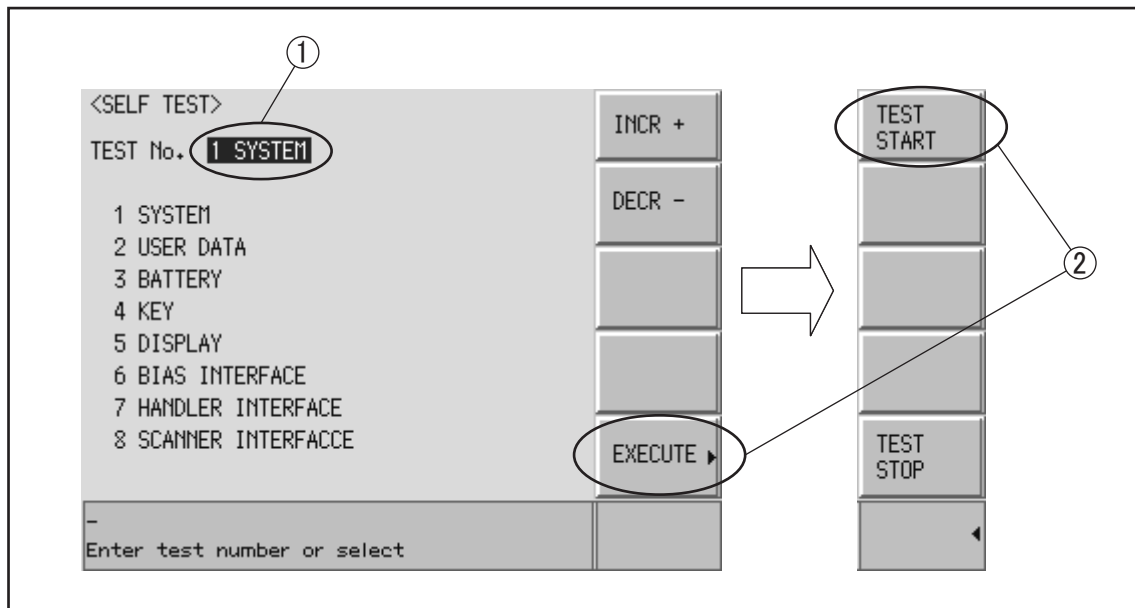

e4980auj1040

The following test items can be checked by using the self-test.

Precautions for Use and Daily Checks
Daily Checks (Executing the self-test)

Self-test items

1 SYSTEM	Checks the system, A1/A2/A3 boards, and system correction data.
2 USER DATA	Checks the settings of GPIB and LAN, instrument setup information, correction data, and scanner's correction data.
3 BATTERY	Checks the internal batteries.
4 KEY	Checks the front panel keys. (Visual confirmation only; no pass/fail result shown on screen.)
5 DISPLAY	Checks the LED/LCD on the front panel. (Visual confirmation only; no pass/fail result shown on screen.)
6 BIAS INTERFACE	Checks the bias interface. (Visual confirmation only; no pass/fail result shown on screen.)
7 HANDLER INTERFACE	Checks the handler interface. (Visual confirmation only; no pass/fail result shown on screen.)
8 SCANNER INTERFACE	Checks the scanner interface. (Visual confirmation only; no pass/fail result shown on screen.)

Cleaning this Instrument

This section explains how to clean the instrument.

WARNING

To protect yourself from electrical shock, be sure to unplug the power cable from the outlet before cleaning the instrument.

Never clean the internal components of the instrument.

Unknown Terminals/DC Source Ports

Unknown terminals and DC source ports (option 001) on the front panel of the E4980A are fitted with BNC Type connectors (m). Stains or other damage to these connectors would significantly affect the measurement accuracy. Please give attention to the following precautions.

- Always keep the connectors free from stains or dust.
- Do not touch the contact surface on the connectors.
- Do not plug damaged or scratched connectors into the test ports.
- Use compressed air to clean connectors. Do not use abrasives under any circumstance.

Cleaning Parts Other than Unknown Terminals and DC Source Ports

To remove stains on parts other than the unknown terminals and DC source ports, wipe them gently with a soft cloth that is dry or one that is wetted with a small amount of water and wrung tightly.

Cautions Applicable to Requesting Repair, Replacement, Regular Calibration, etc.

Caution when Sending the Unit

If it is necessary to send the unit to a Service Center of Agilent Technologies, please follow the instructions below.

Equipment to be Sent

When requesting repair or regular calibration of the unit at our Service Center, send only the E4980A main unit without any installed option. Unless specifically instructed, it is not necessary to send accessories.

Packing

Use the original package and shock absorbers, or equivalent antistatic packing materials, when sending the unit.

Shipping Address

For the address of the nearest Agilent Technologies Service Center, direct inquiries to the Customer Contact shown at the end of this manual.

Recommended Calibration Period

The recommended interval between calibrations of this instrument is one year. Agilent recommends that you request our Service Center to perform regular calibration every year.

13 Troubleshooting

This chapter lists items to check if you encounter a problem while using the Agilent E4980A. All of these items should be carefully investigated before you determine that your E4980A is faulty.

Check Items When Trouble Occurs

The system does not start up (Nothing is displayed)

- o Confirm that the power cable is properly plugged in.
- o Confirm that the fuse is not blown.

If normal operation does not resume after taking the above measures, there is the possibility of a failure. Unplug the power cable immediately and contact Agilent Technologies's Customer Contact, listed at the end of this guide, or the company from which you bought the device.

NOTE

Occasionally, there are missing pixels or constantly lit pixels, but this is not a malfunction and does not affect measurement results.

The system starts up, but the normal measurement screen does not appear (Service Mode)

The Service Mode is a state that occurs when the power-on test fails. Here, the characters on the display turn yellow and all of the front panel keys are unavailable.

- o Confirm that the power-on test or a self test has failed.
When the power-on test at start-up fails, the error message "Power on test failed" is displayed in the system message area.

For details on the Service Mode, refer to the Service Guide.

- o When the power is turned on with the interface board of the E4980A rear panel removed, the E4980A enters the service mode. In this case, reset the interface board and then turn the power on.

The E4980A also enters the service mode when the interface board isn't set properly.

When the normal measurement screen does not appear, there is the possibility of a failure. Contact Agilent Technologies's Customer Contact, listed at the end of this guide, or the company from which you bought the device.

An overload message is displayed

An overload is often detected by the E4980A when nothing is connected to the UNKNOWN terminal.

For conditions where overload occurs, refer to "Displaying Errors instead of Measurement Results" on page 76.

If the measurement/DCR/DCI ranges are set at Hold, enable the auto to select the optimum range. Then set the range at Hold. This may solve a overload.

Beeping persists when turning on the comparator function

- o Confirm that the limit range is set up properly.

When the beep is set up to sound when the comparator function is on, the beep sounds on every completion of measurement if the limit range is set up improperly.

The front panel keys are unavailable

- o Check if the keys are locked.

When the keys are locked, **LOCK** is displayed in the status display area in the lower-right corner of the screen.

Press the [**Local/Lock**] key to unlock the keys.

- o Check if the instrument is in the remote mode.

If the E4980A is in the remote mode, **RMT** is displayed in the status display area in the lower-right corner of the screen.

Press the [**Local/Lock**] key to clear the remote mode.

NOTE

When the E4980A enters a local lockout state by sending the LOCAL LOCK BUS command from the controller, you cannot unlock the remote mode even if you press the [**Local/Lock**] key. (Only **RMT** is displayed in the status display area, so you cannot distinguish the local lockout state from a normal remote mode.)

Send the LOCAL BUS command from the controller to cancel this state, which enables control of the E4980A on the front panel.

Clearly abnormal measured value

- o Measurement of compensation data may have failed.

Measure the compensation data again. For how to measure correction data, refer to “CORRECTION page” on page 115.

- o If the measured value is still abnormal even after taking the above measure, turn off the correction function.

Perform resistance measurement of 100 to 1 k Ω DUT by using the E4980A’s fixture after turning off OPEN/SHORT/LOAD on the CORRECTION page and setting cable length to zero. If a measured value close to the DUT’s value is displayed, there is the possibility of correction failure or inappropriate cable length.

- o When the MULTI compensation is ON, check that the channel and the definition method of the LOAD standard value are selected correctly.

Saving to USB memory fails

Some USB memory does not work with the E4980A. See the section on “USB interface port” on page 420.

An error message or warning message is displayed

For information on error messages and warning messages, refer to “Error Messages” on page 462.

Check Items When Trouble Occurs During Remote Control

The instrument does not respond to the external controller or malfunctions

- o Confirm that the connection setting is correct.
Check that the GPIB address for a GPIB connection or the IP address for a LAN connection is set up correctly on the SYSTEM CONFIG screen of the E4980A or the connection setting screen of the external controller.
- o Confirm that connection cables such as the GPIB cable, USB cable, and LAN cable are connected and in good condition.
- o Check whether another instrument connected by the GPIB or LAN cable has the same GPIB address or IP address.
- o Check that the GPIB cable is not looped.

You cannot read out the measured value.

- o Confirm that the data transfer format is set up correctly.

An error message is displayed

- o Check that the program is correct.
For details on error messages, refer to “Error Messages” on page 462.

A **Manual Changes**

This appendix shows manual changes that need to be made to an earlier revision according to firmware or serial number.

Manual Changes

If your E4980A has the firmware or serial number shown in Table A-1 and Table A-2, see the corresponding manual changes.

Table A-1 **Manual Changes by Firmware Number**

Firmware Number	Make Manual Changes

Table A-2 **Manual Changes by Serial Number**

Serial Number	Make Manual Changes
A.02.00 or later	Change 1
A.02.10 or later	Change 2
A.02.11 or later	Change 3

The ten-character serial number is stamped on the serial number plate (Figure A-1) on the rear panel.

Figure A-1 **Example of Serial Number Plate**



e4980auj1003

Change 3

The following functions are newly added to the firmware revision A.02.11. The firmware revision A.02.11 or below does not support the following function.

- o Change the resolution to 20mA from 1A to 2A of the DC bias signal current level at the connection of two 42841A devices.

Change 2

The following functions are newly added to the firmware revision A.02.10. The firmware revision A.02.10 or below does not support the following function.

- o Command to set the DC bias range has been added.

The firmware revision A.02.10 or below does not support the following SCPI command. Please delete the descriptions about this command from this manual.

- **:BIAS:RANGe:AUTO** on page 289

Change 1

The following functions are newly added to the firmware revision A.02.00. The firmware revision A.02.00 or below does not support the following functions.

- o New softkey which has LAN reset function.
- o Compliant with LXI (Lan eXtensions for Instrumentation) standard Class C
- o DHCP ON/OFF function and AUTO IP address ON/OFF function integrated (IP CONFIG field).
- o “Status” which displays the LAN connection status changed (CURRENT LAN STATUS monitor).

For “Status” of the firmware revision A.02.00 or lower, which displays the LAN connection status, refer to the following table.

Status	Description
OK	LAN connection is OK
DISCONNECTED	Disconnected from the LAN
INITIALIZING	LAN connection is being initialized
FAILED	LAN connection has failed.

The firmware revision A.01.0x does not support the following SCPI command. Please delete the descriptions about this command from this manual.

- **:SYSTem:COMMunicate:LAN[:SELF]:CONFIgure** on page 330

The firmware revision A.02.00 or later does not support the following SCPI commands.

- **:SYSTem:COMMunicate:LAN[:SELF]:AIP[:STATe]** on page 329

Manual Changes
Manual Changes

- **:SYSTem:COMMunicate:LAN[:SELF]:DHCP[:STATe]** on page 331

B **Error Messages**

The Agilent E4980A provides error messages to indicate its operating status. This appendix describes the error messages of the E4980A in alphabetical order.

Error Messages

An error message is displayed in the instrument status display area in the lower-left part of the screen. Pressing any of the front keys other than the [Local/Lock] key or executing the :DISP:CCL command clears the error message. Moreover, when a sweep is started again, the display of a particular error message may disappear. Errors caused by operation of a front panel key simply appear on the display; with a few exceptions, these are not stored in the error queue.

In the log of an error message, a maximum 100 pieces are recorded, and it is possible to go back and check from the oldest error. Executing the :SYST:ERR? command checks error logs. This operation can be performed only by the “SCPI” command. It cannot be operated from the front panel.

An error with a positive error number is one uniquely defined for this instrument. On the other hand, an error with a negative error number is basically one defined for common GPIB devices in IEEE488.2.

When the error code is displayed on the screen of the instrument, there will be a letter “E” with error code and error description are displayed.

E1103 A1 EEPROM write error

A

1103

A1 EEPROM write error

An error is generated while writing data to A1 EEPROM. When this error occurs, contact Agilent Technology’s Sales and Service Office or the company from which you bought the device.

B

62

Bias off, Turn bias on

DC bias sweep is performed with the DC BIAS function OFF.

-160

Block data error

Block data is improper.

-168

Block data not allowed

Block data is not allowed.

C

-140

Character data error

Character data is improper.

-148

Character data not allowed

Character data not allowed for this operation.

-144

Character data too long

Character data is too long (maximum length is 12 characters).

-100	Command Error Improper command.
41	Correction measurement aborted Correction data measurement is aborted.
1201	CPU Bd EEPROM write error An error is generated while writing data to EEPROM. When this error occurs, contact Agilent Technology's Sales and Service Office or the company from which you bought the device.
1200	CPU Bd FLASH ROM write error An error is generated while writing data to FLASH. When this error occurs, contact Agilent Technology's Sales and Service Office or the company from which you bought the device.
29	Cycle power of 42841A and Preset The connection was not established with the 42841A. Cycle the power of the 42841A, then preset the E4980A.
	D
90	Data buffer overflow This error occurs when the amount of data exceeds the defined data buffer memory size. If this error occurs during the measurement after pressing [Save/Recall] - SAVE DATA - START LOG, press SAVE & STOP.
-230	Data corrupt or stale The setting file or correction data to be read cannot be read out with the current firmware version because the setting file or correction data is corrupt or old.
-222	Data out of range A data element (not violating the standard) outside the range defined by this instrument has been received. This error occurs, for example, when an integer-based command for which the parameter can be rounded exceeds the range of -2147483648 to +2147483647 or when a real-number-based command for which the parameter can be rounded exceeds the range of -9.9e37 to +9.9e37. This error also occurs when a numeric value other than a specified one is entered into a command in which the "BIN number" and "list table number" are specified as parameters and thus the parameters are not rounded.
-104	Data type error Improper data type used (for example, string data was expected, but numeric data was received).
26	DC bias I sink overload DC bias sink current is overloaded. When this error occurs, lower the value of the current setting.
25	DC bias I source overload DC bias source current is overloaded. When this error occurs, lower the value of the current setting

Error Messages

Error number: 19

- 19 **DC bias not available**
DC bias cannot be turned on in Rdc measurement.
- 18 **DC bias opt not installed**
Operation that requires option 001 is performed in a model not having the power amp/DC bias option (option 001).
- 28 **DC bias unit connection changed**
The connection with the 42841A has been changed. Cycle the power of the 42841A, then preset the E4980A.
- 27 **DC bias unit disconnected**
The 42841A is not connected. Confirm the connection to the 42841A.
- 20 **DC bias unit powered down**
The 42841A is switched off. Turn on the switch.
- 63 **DC source off, Turn DC source on**
DC source sweep is performed with the DC source function OFF. Set the DC source function to ON.

E

- 10 **Exceeded AC+DC limit**
The amount of the voltage level exceeds 42V peak. Lower the DC voltage or AC voltage setting.
- 200 **Execution error**
An error associated with execution has been generated for which this instrument cannot specify the error message. This code indicates that an error associated with execution defined in 11.5.1.1.5, IEEE488.2 has occurred.

- 123 **Exponent too long**
The magnitude of the exponent was larger than 32000.

- 178 **Expression data not allowed**
Expression data is not allowed.

- 170 **Expression error**
Expression is improper.

F

- 1070 **Fan failed**
Cooling fan hardware failure is detected. When this error occurs, contact Agilent Technology's Sales and Service Office or the company from which you bought the device.

- 21 **Fixture circuit defective**
A fault has occurred in a circuit to absorb back-emf of the 42842A/B. Confirm the connection to the 42842A/B.

- 24 **Fixture cover open**

- The protective cover of the 42842A/B is open. Close the cover.
- 23 **Fixture OPEN det. defective**
- The opening and closing detection sensor of the 42842A/B protective cover detects an error. When this error occurs, contact Agilent Technology's Sales and Service Office or the company from which you bought the device.
- 22 **Fixture over temperature**
- The temperature inside the 42842A/B bias test fixture exceeds the limit. Turn off the DC bias and cool down the equipment.
- 30 **Function type not available**
- The Ls-Rdc, Lp-Rdc and Vdc-Idc are not available when the 42841A is connected.
- G**
- 105 **GET not allowed**
- GET is not allowed inside a program message.
- H**
- 70 **Handler I/F not installed**
- The handler interface function is set to ON in a model that does not have a handler interface board (option 201).
- 114 **Header Suffix out of Range**
- The header suffix is out of range.
- I**
- 35 **I BIAS I/F disabled**
- This error occurs when DC bias current is selected when the DC bias interface board (option 002) is not available in a model that does not have the Power/DC bias enhance option (option 001).
- 73 **I BIAS I/F not installed**
- The DC bias interface function is set to ON in a model that does not have the DC bias interface board (option 002).
- 224 **Illegal parameter value**
- The parameter value is not properly set. This error occurs, for example, when the :FUNC:IMP command is used to specify an Impedance-parameter that does not exist (as CPRS).
- 51 **Inconsistent limit setting**
- For the comparator function, user attempts to set the threshold in the sequential mode by sending the COMP:SEQ:BIN command, although the tolerance mode is now selected. Select the sequential mode using COMP:MODE.
- 161 **Invalid block data**
- Invalid block data was received (for example, END received before length satisfied).

Error Messages

Error number: -101

- 101 **Invalid character**
Invalid character was received.
- 141 **Invalid character data**
Bad character data or unrecognized character data was received.
- 121 **Invalid character in number**
Invalid character in numeric data.
- 171 **Invalid expression**
Invalid expression was received (for example, illegal character in expression).
- 103 **Invalid separator**
The message unit separator (for example, “;”, “;”) is improper.
- 151 **Invalid string data**
Invalid string data was received (for example, END received before close quote).
- 131 **Invalid suffix**
Units are unrecognized, or the units are not appropriate.
- M**
- 250 **Mass storage error**
An error occurred while accessing the USB memory. A USB memory-related error other than -257 error (File Name Error) occurred.
- 43 **Measurement failed**
A measurement error occurred during correction data measurement. The OPEN or SHORT state connected to the UNKNOWN terminals may be inappropriate.
- 109 **Missing parameter**
The number of parameters is less than that required for the command, or the parameter has not been entered. For example, the command “:CORR:USE” requires one more parameter. Therefore, when a message “:CORR:USE” is sent to a correct program message “:CORR:USE 11,” this instrument receives the former message as an invalid one because all parameters have not been entered. Enter command parameters correctly.
- N**
- 83 **No data to load**
There is no setup data for the selected number. Or the USB memory is not inserted.
- 60 **No values in sweep list**
List sweep measurement is performed when the measurement point is not set on the LIST SWEEP SETUP screen.
- 128 **Numeric data error**
Numeric data is improper.
- 128 **Numeric data not allowed**

Numeric data not allowed for this operation.

O

83 **Out of Memory**

The E4980A has insufficient memory to perform the requested operation.

P

-220 **Parameter error**

When a parameter-related error other than Errors -221 through -229 occur, this error message is displayed.

-108 **Parameter not allowed**

The number of parameters exceeds that required for the command. For instance, when a program message “:FORM:BORD NORM, ASC” is sent instead of a correct program message with a command “:FORM:BORD NORM”, which requires a parameter, the instrument receives the message that the number of parameters is invalid. See the command reference to confirm the required number of parameters.

1080 **Power failed**

Power unit hardware failure is detected. Contact Agilent Technology’s Sales and Service Office or the company from which you bought the device.

1000 **Power on test failed**

An error occurs during a self test at power-on. The E4980A may be faulty. Contact Agilent Technology’s Sales and Service Office or the company from which you bought the device.

A self test fails when an interface board is removed or not connected properly. Check the connection with a cable when you change the setting of the interface board.

-112 **Program mnemonic too long**

Program mnemonic is too long (maximum length is 12 characters).

Q

-350 **Queue overflow**

There is no room in the queue and an error occurred but was not recorded. Clear the error queue.

-430 **Query DEADLOCKED**

Input buffer and output buffer are full; cannot continue.

-400 **Query error**

Query is improper.

-410 **Query INTERRUPTED**

Query is followed by DAB or GET before the response is completed.

-420 **Query UNTERMINATED**

Addressed to talk, incomplete program message received.

Error Messages

Error number: -440

- 440 **Query UNTERMINATED error after indefinite response**
A query that requests arbitrary data response (*IDN? and *OPT? queries) is sent before normal queries in a program message (for example, **FREQ?;*IDN?** is expected, but ***IDN?;FREQ?** is received).
- R**
- 16 **Reference Measurement aborted**
Reference data measurement is aborted.
- S**
- 71 **Scanner I/F not installed**
Operation that requires option 301 is performed in a model that does not have a scanner interface board (option 301).
- 82 **Signal source overload**
The test signal current exceeds the value shown in Table 11-6. The measurement data is not guaranteed to be valid. The measurement result output is set to 3. Reduce the test signal level so that the test signal current doesn't exceed the value shown in Table 11-6.
- Store failed**
User attempts to save data into the USB memory when a USB memory device is not inserted. Prepare the USB memory device or save data into number 0 to 9.
This error may appear when you attempt to save data immediately after inserting the USB memory into the E4980A. You need to wait for a few seconds after inserting the USB.
- 150 **String data error**
String data is improper.
- 158 **String data not allowed**
String data is not allowed.
- 138 **Suffix not allowed**
A suffix is not allowed for this operation.
- 102 **Syntax error**
Unrecognized command or data type was received.
- T**
- 223 **Too many digits**
The received numeric value is too long (exceeds 255 digits).
- 223 **Too much data**
The block-, expression-, or character-string-type program data that are received conform with the standard but exceed the amount that can be processed under the condition of the memory or conditions specific to memory-related devices. In this instrument, this error occurs when the number of characters exceeds 254 in a character-string parameter.
- 211 **Trigger ignored**

The instrument receives and detects a trigger command (“:TRIG”) or an external trigger signal, but it is ignored due to the timing condition (the instrument is not in the wait-for-trigger state, for example). Change the setup so that a trigger command or an external trigger signal can be sent after the instrument has entered the wait-for- trigger state.

U

-113

Undefined header

A command not defined in this instrument, though not illegal in the syntactic structure, has been received. For example, when the message “:OUTP:DC:ISOL:FREQ:AUTO ON” is sent instead of the correct program message “:OUTP:DC:ISOL:LEV:AUTO ON” the message sent is received as an undefined command by this instrument. See the command reference and use the correct command.

V

14

V bias disabled

The DC voltage bias is set when the 42841A is connected. Set the DC current bias or disconnect the 42841A.

45

Valid in single mode only

SINGLE channel correction data is measured when the MULTI channel correction mode is set.

Warning Messages

A warning message is displayed in the instrument status display area in the lower-left part of the display. Pressing any of the front keys other than the [Local/Lock] key or executing the :DISP:CCL command clears the message.

This message simply appears on the display since it is not known to remote environments such as GPIB. This message is not displayed when another error message is already displayed in the instrument message/warning area.

The warning messages for this instrument are as follows.

Numeric

1 I bias unit

The E4980A finds one current bias unit (42841A) connected.

2 I bias units

The E4980A finds two current bias units (42841A) connected.

A

ALC unable to regulate

The voltage level setting is inappropriate for using the ALC function. The ALC function does not work and the operation will be the same as when the ALC function is turned off. The measurement data status is set to 4. Refer to “Automatic level control” on page 96.

C

Can't change while DCI Isolation OFF

This message appears when the DCI measurement range (DCI RND) is changed when the bias current isolation function is OFF. Turn on the Bias current isolation function.

Can't change while 2nd sweep param exists

This message appears when attempting to change or delete the list sweep parameter from the E4980A's screen after setting the sweep point for the second parameter with the GPIB command. Use the GPIB command to change the list sweep parameter.

Clear the table first

This error occurs when the value of MODE has been changed when the LIMIT TABLE SETUP screen is moved to another screen or the sweep parameter on the LIST SWEEP SETUP screen is changed even though a sweep list for another measurement parameter exists. Clear the table first.

Correction, not effective

The correction function does not work because the MULTI correction mode is used but the test frequency is not equal to the spot frequency.

I

Improper high/low limits

The upper limit value is less than the lower limit value. Set the lower limit value to less than the upper limit value.

Incompatible state file

The setting file recalled from a USB memory device has been saved using an E4980A with a different firmware version or different options. There may be some parameters set up incorrectly. Check the setting.

This message may appear when the connection status of the 42841A is different from the one when it has been saved.

S

Signal source overload

The test signal current exceeds a value shown in Table 11-6. The measurement data is not guaranteed to be valid. The measurement result data status of the measurement result output is set to 3. Reduce the test signal level so that the test signal current doesn't exceed a value shown in Table 11-6.

Signal source overvoltage

The signal source voltage exceeds its limit. Lower the voltage setting of the signal source.

Error Messages
Error number:

C **List of Default Values**

This appendix gives the default values, settings for Save/Recall of an object, and settings for backing up an object when using the Agilent E4980A.

List of Default Values, Save/Recall Settings, and Backup Settings

The table below shows the following settings for the Agilent E4980A. For the factory default settings of the LAN, refer to **List of LAN Factory Default Settings** on page 478.

- Factory-shipped settings (when you press [Preset] - **FACTORY DEFAULT**)

All data that the user can set are cleared. The system date and time, however, are not cleared.

- Preset settings (the status when you press [Preset] - **CLEAR SET & CORR** key or execute the **:SYST:PRES** command)

Calibration data and items that are backed up in the List of Default Values are cleared.

- ***RST** Settings (the status when you press [Preset] - **CLEAR SETTING** key or execute the ***RST** command)

Basic setting parameters which can be set from the front panel or the SCPI commands are cleared.

- Settings that permit Save/Recall of a setup state

In the table, states that can be saved/recalled are denoted in the following manner:

* : Save/Recall can be performed

Blank: Save/Recall cannot be performed

- Settings that are backed up (set state not affected by turning power ON/OFF)

In the table, a setting that is automatically backed up is denoted in the following manner:

* : Backup operation performed

Blank: Backup operation not performed

- Available means of defining a setting

In the table, the following symbols are used to denote the method(s) that can be used to define a setting.

K: Using the front panel key

C: Using the SCPI command

NOTE

In the table, the “<<” symbol shows that the setup is the same as that in the box to the left.

List of Default Values

Key Operation	Factory-shipped Setting	Default Value		Save/ Recall	Backup	Available Means of Defining a Setting
		Preset	*RST			
[DC Bias]	OFF	<<	<<			K/C
[DC Source]	OFF	<<	<<			K/C
[Display Format]						
BIN COUNT						
COUNT	OFF	<<	<<	*		K/C
BIN No.						
COMP	OFF	<<	<<	*		K/C
LIST SWEEP						
MODE	SEQ	<<	<<	*		K/C
MEAS DISPLAY						
BIAS	0 V	<<	<<	*		K/C
FREQ	1 kHz	<<	<<	*		K/C
FUNC	Cp-D	<<	<<	*		K/C
LEVEL	1 V	<<	<<	*		K/C
MEAS TIME	MED	<<	<<	*		K/C
RANGE	AUTO(ON)	<<	<<	*		K/C
[Local/Lock]	OFF	<<	<<			K/C
[Meas Setup]						
CORRECTION						
CABLE	0 m	<<			*	K/C
CH	0	<<	<<			K/C
FREQ	OFF	<<			*	K/C
FUNC	Cp-D	<<			*	K/C
LOAD	OFF	<<			*	K/C
LOAD A	---	<<			*	K/C
LOAD B	---	<<			*	K/C
OPEN	OFF	<<			*	K/C
OPEN A	---	<<			*	K/C
OPEN B	---	<<			*	K/C
SHORT	OFF	<<			*	K/C

List of Default Values
List of Default Values

Key Operation	Factory-shipped Setting	Default Value		Save/ Recall	Backup	Available Means of Defining a Setting
		Preset	*RST			
SHORT A	---	<<			*	K/C
SHORT B	---	<<			*	K/C
REF A	---	<<			*	K/C
REF B	---	<<			*	K/C
SPOT No.	1	<<	<<		*	K/C
LIMIT TABLE						
AUX	OFF	<<	<<	*		K/C
BEEP	FAIL	<<	<<		*	K/C
COMP	OFF	<<	<<	*		K/C
FUNC	Cp-D(OFF)	<<	<<	*		K/C
MODE	%	<<	<<	*		K/C
NOM	0 F	<<	<<	*		K/C
LIST SETUP						
MODE	SEQ	<<	<<	*		K/C
MEAS SETUP						
ALC	OFF	<<	<<	*		K/C
AVG	1	<<	<<	*		K/C
BIAS	0 V	<<	<<	*		K/C
BIAS POL	FIX(OFF)	<<	<<	*		K/C
DC SRC	0 V	<<	<<	*		K/C
DCI ISO	OFF	<<	<<	*		K/C
DCI RNG	20 mA	<<	<<	*		K/C
DCR RNG	AUTO	<<	<<	*		K/C
DEV A	OFF	<<	<<	*		K/C
DEV B	OFF	<<	<<	*		K/C
FREQ	1 kHz	<<	<<	*		K/C
FUNC	Cp-D	<<	<<	*		K/C
IDC MON	OFF	<<	<<	*		K/C
LEVEL	1 V	<<	<<	*		K/C
MEAS TIME	MED	<<	<<	*		K/C
RANGE	AUTO	<<	<<	*		K/C
REF A	0 F	<<	<<	*		K/C

Key Operation	Factory-shipped Setting	Default Value		Save/ Recall	Backup	Available Means of Defining a Setting
		Preset	*RST			
REF B	0	<<	<<	*		K/C
STEP DLY	0 s	<<	<<	*		K/C
TRIG	INT	<<	<<	*		K/C
TRIG DLY	0 s	<<	<<	*		K/C
USER COMMENT	""	<<	<<	*		K/C
VDC MON	OFF	<<	<<	*		K/C
[Recall A]	-					K/C
[Recall B]	-					K/C
[Save/Recall]						
MEDIA	INT	<<	<<			K/C
[System]						
SYSTEM CONFIG						
BEEPER ENABLE	OFF				*	K/C
BEEPER TONE	3				*	K/C
DATE/TIME	-					K/C
GPIB ADDR	17				*	K/C
IP CONFIG	AUTO				*	K/C
MANUAL GATEWAY	"0.0.0.0"					K/C
MANUAL IP ADDR	"192.168.1.101"					K/C
MANUAL SUBNET MASK	"255.255.255.0"					K/C
TIME ZONE	+00:00				*	K/C
SYSTEM INFO						
CURR BIAS I/F	-					K/C
HANDLER I/F	-					K/C
SCANNER I/F	-					K/C

List of LAN Factory Default Settings

The following settings return to the factory default settings when you press [Preset] - **LAN RESET** or execute **:SYST:COMM:LAN:PRES** command.

This can also be executed by using the Factory Defaults button on the View & Modify Configuration page of the web server.

Setting Items	Control from the E4980A	Control via Web Server	Reconnection *1	Preset Value
IP Configuration	Available	Available	Required	AUTO
IP Address	Available	Available	Required	192.168.1.101
Subnet Mask	Available	Available	Required	255.255.255.0
Default Gateway	Available	Available	Required	0.0.0.0
Dynamic DNS	Not available	Available	Required	ON
DNS Servers	Not available	Available	Required	USE DHCP
DNS Server	Not available	Available	Required	0.0.0.0
DNS Server	Not available	Available	Required	0.0.0.0
Hostname	Not available	Available	Required	a-e4980a-xxxxx *2
Domain Name	Not available	Available	Required	
NetBIOS	Not available	Available	Not required	ON
Ethernet Connection Monitoring	Not available	Available	Not required	ON
Description	Not available	Available	Not required	E4980A
TCP Keep Alive	Not available	Available	Not required	ON
TCP Keep Alive Time	Not available	Available	Not required	1800

*1. If you change the item which requires reconnection of the network, a message "Click 'Renew LAN Settings' to make saved changes effective" will appear.

*2. xxxxx indicates the serial number of the E4980A.

D Bias Current Interface

This chapter explains how to use Option 002 Bias Current Interface, which adds a digital interface to allow the E4980A to control the Agilent E4980A Precision LCR Meter's bias current source.

Product Overview

42841A Bias Current Source

The 42841A is a DC bias current source for use with the E4980A (with Option 002 Bias Current Interface). All measurement setups, including the DC current bias, can be set from the E4980A front panel.

Operation Limitations

Some E4980A functions have the following limitations when used with the 42841A and the 42842A/B.

- o Option 001, Internal DC Bias is disabled.
- o DC Bias test signal voltage (V) is disabled.
- o Test signal voltage monitor (VDC MON) is disabled.
- o Test signal current monitor (IDC MON) is disabled.
- o Auto bias polarity control function (BIAS POL) cannot be set to AUTO.
- o Measurement range is only 10 Ω and 100 Ω .
- o Cable length setting applies only to the 1 m setting.

CAUTION

Turn off all the power switches of the 42841A and E4980A when connecting or disconnecting any connection involving 42841A and E4980A.

NOTE

The 42842C bias current test fixture cannot be used with the E4980A.

Specifications when Measuring with the 42841A

Table D-1 shows the DC bias signal current level when the 42841A is connected.

The measurement accuracy (typical) when connecting the E4980A to the 42841A is the same as that when connecting the 4284A to the 42841A, described in the Specifications of the 42841A manual. When test frequency exceeds 1 MHz (the highest value in the 42841A manual), we assume an accuracy that is double the accuracy at 1 MHz test frequency.

Table D-1 DC bias signal current level

Range	E4980A only	-100 mA to 100 mA
	Connected with 42841A	0 A to 20 A (connect 42841A x 1 unit) 0 A to 40 A (connect 42841A x 2 units)
Resolution	E4980A only	1 μ A (0 A to 50 mA) 10 μ A (50 mA to 100 mA)
	Connected with 42841A	10 mA (0 A to 1 A) 100 mA (1 A to 20 A) (connect 42841A x 1 unit) 20 mA (0 A to 2 A) 200 mA (2 A to 40 A) (connect 42841A x 2 units)

Preparation

Equipment Requirements

The 42841A supplies 20 A (1 unit) and 40 A (2 units) DC current bias when combining the E4980A (test frequency: 20 Hz to 2 MHz) and the 42842A/B test fixture.

The following equipment is necessary for a system that uses the E4980A and the bias current source.

- E4980A Precision LCR Meter (with Option 002 Bias Current Interface)
- 42841A Bias Current Source (two units are necessary for 40 A system)
- 42842B Bias Current Test Fixture (only 42842B for 40 A system)
- 16048A Test Lead (with BNC connector)
- Bias Current Interface Cable (furnished with the 42841A)
- 42843A Bias Current Cable (required only for 40 A system)

NOTE

Confirm that Option 002 Bias Current Interface is installed in the option slot of the E4980A's rear panel. When option 002 is installed, the 50-pin connector marked "Option 002: Bias Current Interface" is attached to either of the two option slots of the rear panel.

Cable Connection

Each instrument needs to be connected using the bias current interface cable, 16048A test lead, and 42843A bias current cable (only for 40 A system). The cable connection varies depending on the system configuration.

20A System

Connect the E4980A to the 42841A and 42842A as shown in Figure D-1 on page 483 using the following procedure.

1. Connect the UNKNOWN terminal of the E4980A to the TO UNKNOWN terminal of the 42842A using the 16048A test lead.
2. Connect the Bias Current Interface connector of the E4980A to the Bias Current Control Input A connector of the 42841A using the cable and the adapter. The cable is furnished with the 42841A and the adapter is furnished with the E4980A.
3. Connect the 42842A test fixture directly to the front panel of the 42841A.

Figure D-1 Cable connection for an E4980A (20 A) system

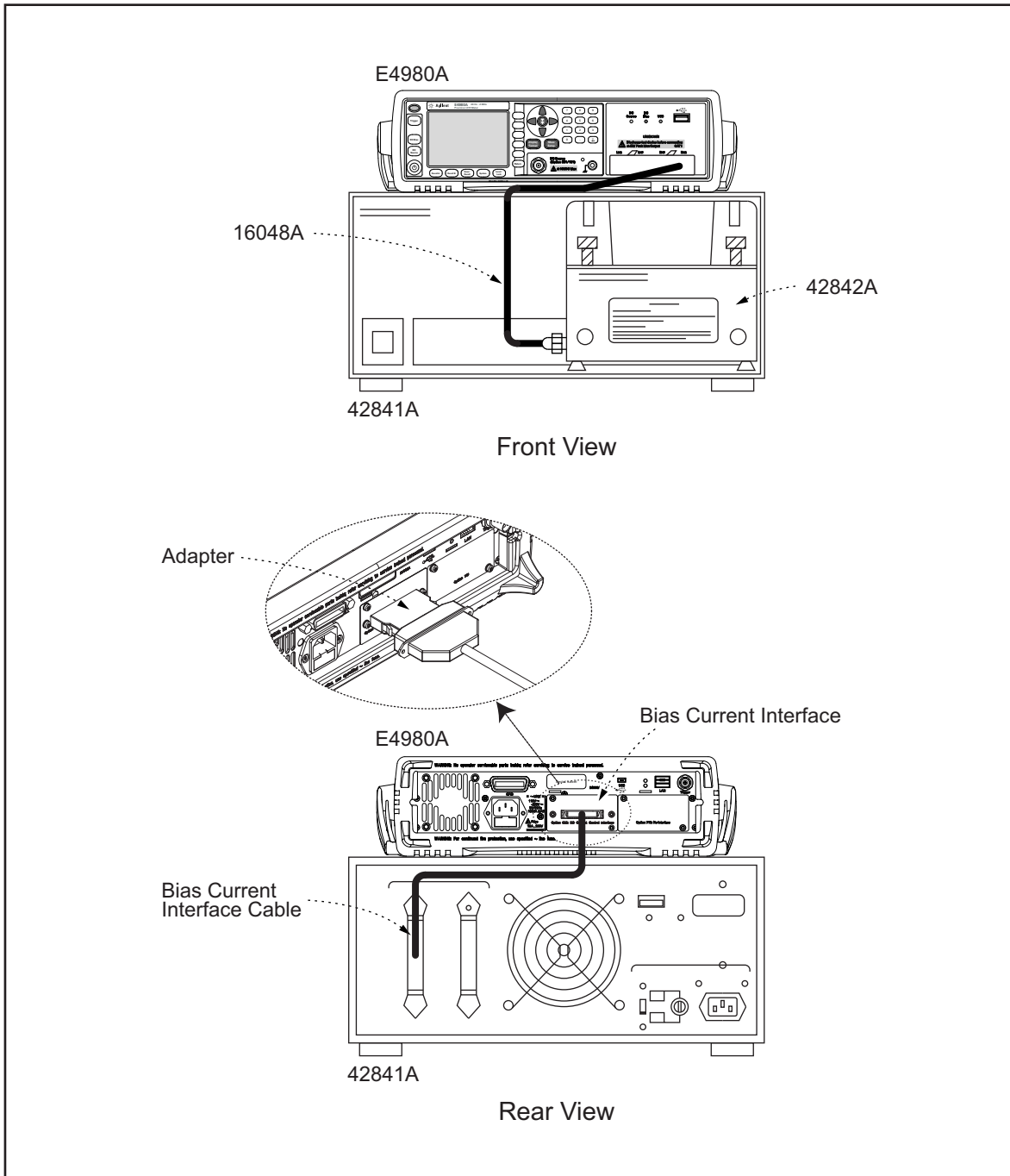

D. Bias Current Interface

e4980aue1132

Bias Current Interface Preparation

40 A System

Connect the E4980A to the 42841A and the 42842B as shown in Figure D-2 on page 485 using the following procedure.

1. Connect the UNKNOWN terminal of the E4980A to the TO UNKNOWN terminal of the 42842B using the 16048A test lead.
2. Connect the 42842B test fixture directly to the front panel of the 42841A.
3. Connect the DC Bias Current Output Connector of the 42841A (that is not connected to the 42842B and DC Bias Current Input Connector of the 42842B side panel) using a 42843A Bias Current Cable.
4. Connect the E4980A Bias Current Interface connector to the Bias Current Control Input A connector of the 42841A using the furnished Bias Current Interface Cable (1) and the adapter. The cable is furnished with the 42841A and the adapter is furnished with the E4980A.
5. Connect the 42841A Bias Current Control Input B connector connected to the 42842B to the Bias Current Control Input A connector of the other 42841A using the furnished Bias Current Interface Cable (2).

Figure D-2 Cable connection for an E4980A(40 A) system

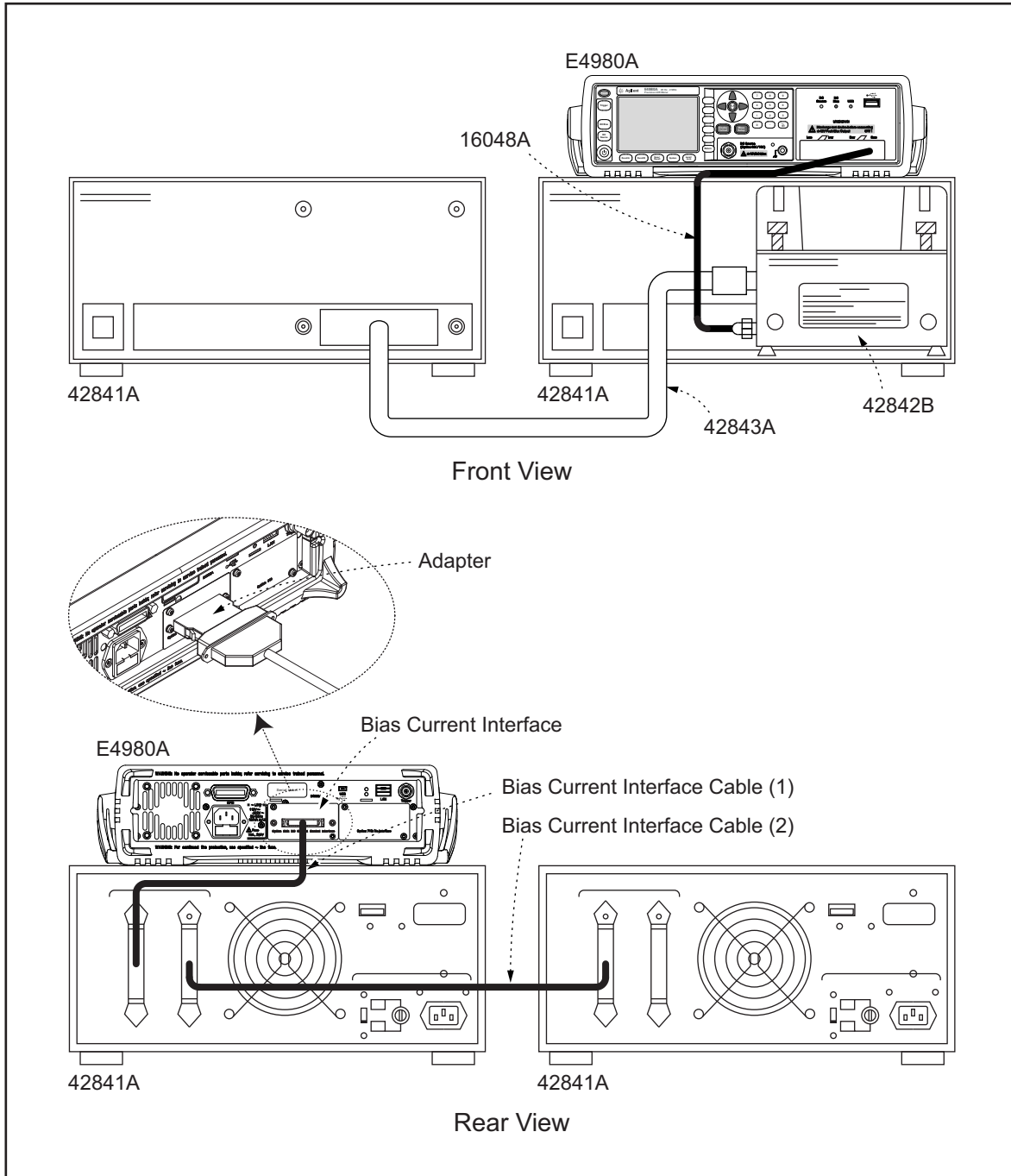

e4980aue1176

D. Bias Current Interface

Measurement Procedures

For measurement procedures when using the 42841A Bias Current Source, see “Basic Measurement Procedure” of the Chapter, “Operation Procedure and Examples” in the 42841A manual. The measurement procedure is the same as that of the 4284A.

E **Scanner Interface**

This chapter provides electrical characteristics of the interface signal line necessary to use the Agilent E4980A Precision LCR meter option 301.

Overview

When the Agilent E4980A is used with the option 301 Scanner Interface, it is possible to store and use up to 128 sets of correction data (OPEN, SHORT, and LOAD) for up to 201 user-defined test frequencies. These 128 sets of correction data can be used for each measurement using the multi-channel correction function.

The E4980A can correct stray admittance, residual impedance, and other errors for each channel from the calibration plane to the connection contacts at the device. Therefore, option 301 of the E4980A can accurately measure impedance values without any degradation of repeatability, or differences between channels. Timing synchronization is also provided.

An amphenol 14-pin connector is used to interface between the E4980A and the scanner.

Figure E-1 Multi-channel Correction Data Memory Model

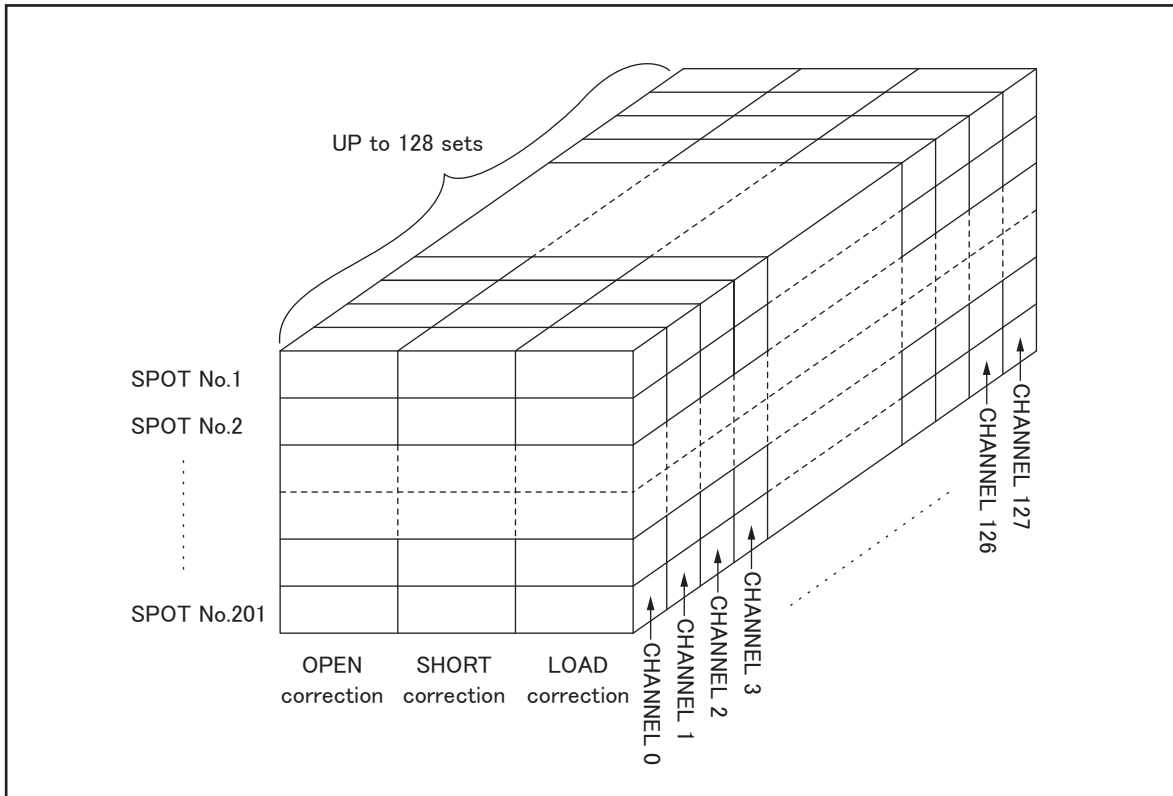

e4980aue1152

Specifications

Specifications

Table E-1 Scanner Interface Specifications

Interface Connector		Amphenol 14-pin connector
Maximum Number of Channels		128 (CH0 to CH127)
Output Signal	/INDEX	Analog measurement complete (1 bit)
	/EOM	Full measurement complete (1 bit)
Input Signal	/CH0 to /CH7	8-bit parallel input signals for selecting the channel
	/CH_VALID	Signal valid or invalid for /CH0 to /CH7
	EXT_TRIG	External trigger signal
Multi-channel Correction		The multi-channel correction function can store OPEN, SHORT, and LOAD correction data for each channel independently and compensate each channel. The correction data at 201 test frequencies can be stored in a flash memory.

Supplemental Performance Characteristics

Electrical Characteristics

Table E-2 Input Signal Characteristics: Opto-isolated, negative true

Signal Name	Input Voltage Rate		External Pull-up Voltage	Input Current
	High	Low		
/CH0 to /CH7 /CH_VALID	Pull-up Voltage	≤ 1 V	5 to 15 V	5 to 20 mA
EXT_TRIG	Pull-up Voltage	≤ 1 V	5 to 15 V	6.3 to 15 mA

Table E-3 Output Signal Characteristics: Opto-isolated, negative true

Signal Name	External Pull-Up Voltage	Maximum Current
/INDEX /EOM	Max. 15 V	6 mA

Signal Input/Output Connector

The scanner interface I/O connector, a 14-pin amphenol connector, is mounted in the option slot of the E4980A's rear panel for interconnection between the E4980A and the scanner.

Scanner Interface Input/Output Signals

The scanner interface I/O signals are divided into the following three types:

- Channel selection input signals
- Control output signals
- Control input signals

Each signal is described in detail below.

Channel selection input signals

These signals are used to select the correction data that correspond to the channel number of the scanner.

/CH0 to /CH7	Channel selection signals (8-bit, binary input). Select the correction data corresponding to the channel of the scanner. The most significant bit is /CH7 and the least significant bit is /CH0.
/CH_VALID	Channel valid signals. This signal makes the channel number set by the channel selection signals valid or invalid.

NOTE

Since there are 128 channels, the /CH0 to /CH6 bits are manipulated.

Control output signals

These signals are used to control the timing between the E4980A and the scanner.

/INDEX	Analog measurement complete. Since this signal is asserted when an analog measurement is completed, the channel can be switched to the next one. Measurement data, however, cannot be obtained until /EOM is asserted.
/EOM	End of measurement. Since this signal is asserted when a series of measurement is completed, the E4980A moves to the next measurement. When this signal is asserted, the measurement data and the comparison results are valid.

Assertion timing for /INDEX and /EOM is different for normal measurements and list sweep measurements.

Table E-4 Control output signal assertion timing (normal measurement)

Signal Name	Timing
/INDEX	/INDEX is asserted when an analog measurement is completed and the E4980A is ready for the next DUT to be connected to the UNKNOWN terminals.

Table E-4 Control output signal assertion timing (normal measurement)

Signal Name	Timing
/EOM	/EOM is asserted when the measurement data and the comparison results are valid.

Table E-5 Control output signal assertion timing (list sweep measurement, SEQ mode)

Signal Name	Timing
/INDEX	/INDEX is asserted when the last analog measurement of a list sweep measurement is completed.
/EOM	/EOM is asserted when all list sweep measurements are completed and the measurement results are valid.

Table E-6 Control output signal assertion timing (list sweep measurement, STEP mode)

Signal Name	Timing
/INDEX	/INDEX is asserted when each analog measurement of a sweep measurement is completed.
/EOM	/EOM is asserted when each step measurement, including comparison and display time, is completed.

Control Input Signal

Trigger signal to start measurement.

EXT_TRIG External trigger. This signal triggers the E4980A on the rising edge of a pulse when the trigger mode is set to EXT_TRIG.

NOTE The / (slash) in the signal name means that the signal is asserted when low.

Scanner Interface
Signal Input/Output Connector

Scanner Interface I/O Connector Pin Assignments

The pin assignments for the scanner interface I/O connector are shown in Figure E-2 and Table E-7.

Figure E-2 Scanner interface I/O connector pin assignments

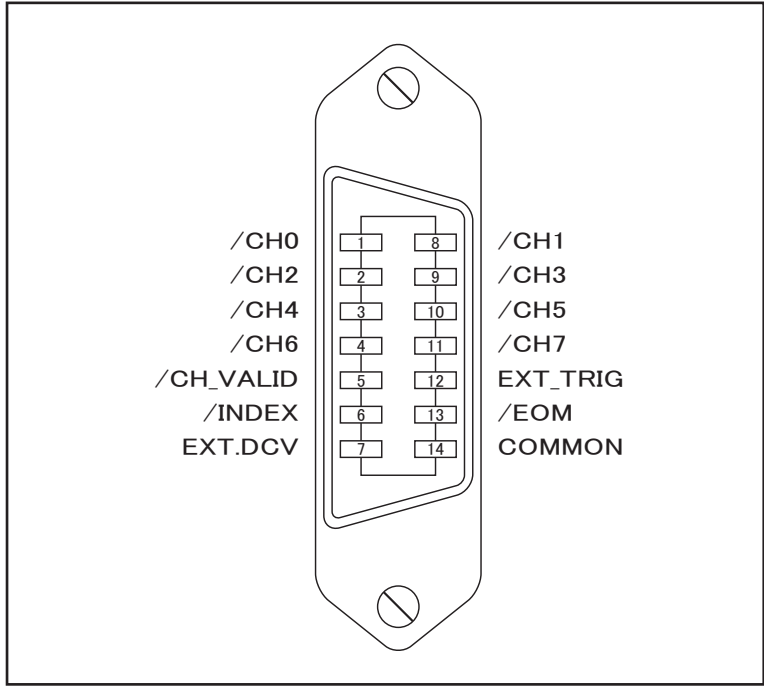

e4980auj1153

Table E-7 Scanner interface I/O connector pin assignments

Pin No.	Signal Name	Input/Output	Description
1	/CH0	Input	Channel Selection Signal
2	/CH2		
3	/CH4		
4	/CH6		
5	/CH_VALID	Input	Channel Valid Signal
6	/INDEX	Output	Analog Measurement Complete Signal.
7	EXT.DCV	Input	External DC Voltage. Used as pull-up voltage of input/output signals. The setting range is from 5 V to 15 V.
8	/CH1	Input	Channel Selection Signal
9	/CH3		
10	/CH5		
11	/CH7		

Table E-7 Scanner interface I/O connector pin assignments

Pin No.	Signal Name	Input/Output	Description
12	EXT_TRIG	Input	External Trigger Signal
13	/EOM	Output	End-of-Measurement Signal
14	COMMON	-	Common for EXT. DCV

NOTE Assertion timing for these signals is different from normal measurements and list sweep measurements.

The scanner system will operate more efficiently when the following input/output control signals are used:

- Step 1.** Set the scanner channel to CHANNEL 0, the first scanner channel.
- Step 2.** Set the channel selection signals (/CH0 to /CH7) and the channel valid signal (/CH_VALID) to compensate CHANNEL 0.
- Step 3.** Trigger the E4980A with a trigger pulse input through the scanner input/output connector on the rear panel. The E4980A will acknowledge the channel number as CHANNEL0 and then measure the device connected to scanner channel 0 using the correction data for it.
- Step 4.** Disassert /CH_VALID after disasserting /INDEX.
- Step 5.** Set the scanner channel, channel selection signals, and the channel valid signal to the next channel to be measured when /INDEX is asserted.
- Step 6.** After /EOM is asserted, the E4980A is ready to make the next measurement.
- Step 7.** Repeat Step 4 through Step 6.

Timing Chart

The timing chart is shown in Figure E-3.

Figure E-3 Timing chart (Normal measurement)

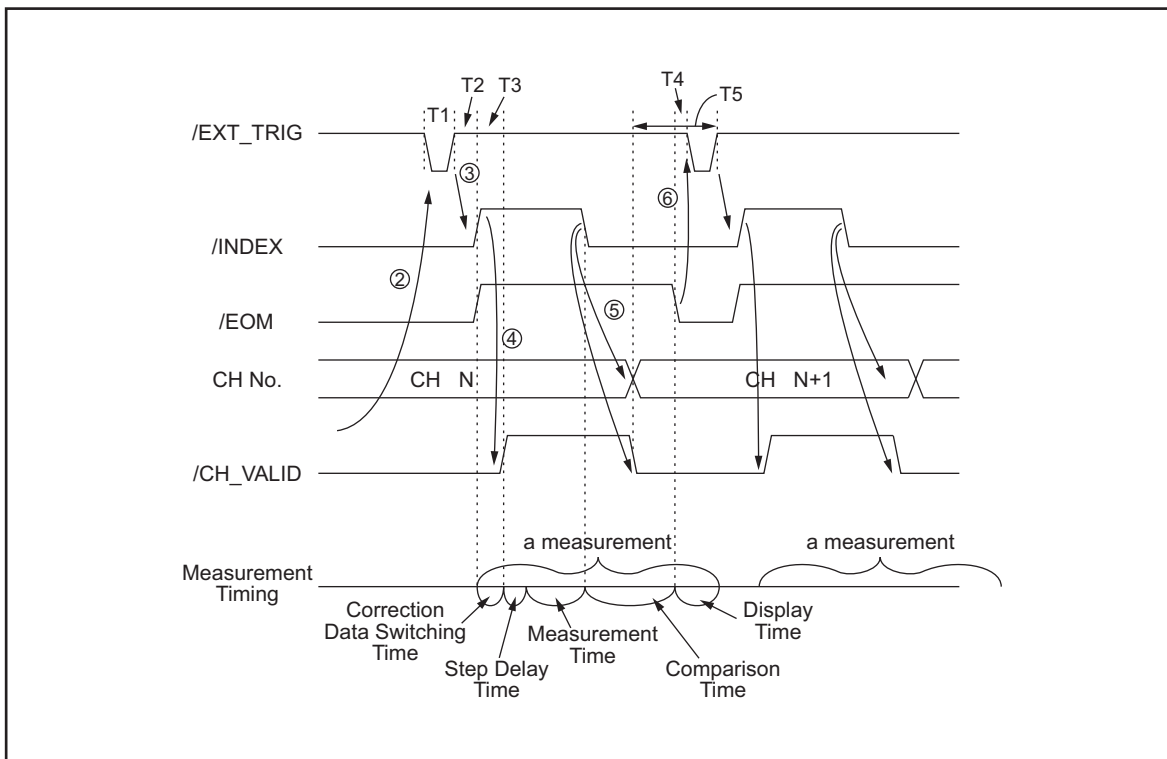

e4980aue1170

Correction Data Switching Time	0 nsec
Measurement Time	Refer to Chapter 11, "Specifications and Supplemental Information," on page 399.
Comparison Time	approx. 1 msec (typical)
Display Time	MEAS DISPLAY page approx. 10 msec BIN No. DISPLAY page approx. 10 msec BIN COUNT DISPLA page approx. 10 msec

Table E-8 Each time of the timing chart

Time		Minimum	Typical*1
T1	Trigger Pulse Width	1 μsec	-
T2	Measurement Start Delay Time	-	350 μsec
T3	/CH_VALID Wait Time after Measurement Start	0 nsec	-
T4	Wait Time after /EOM Output	0 μsec	-
T5	/CH_VALID Setup Time	0 μsec	-

*1. The measurement time is affected by the GPIB/USB/Network and Front panel processes.

Figure E-4 Timing Chart (List sweep measurement)

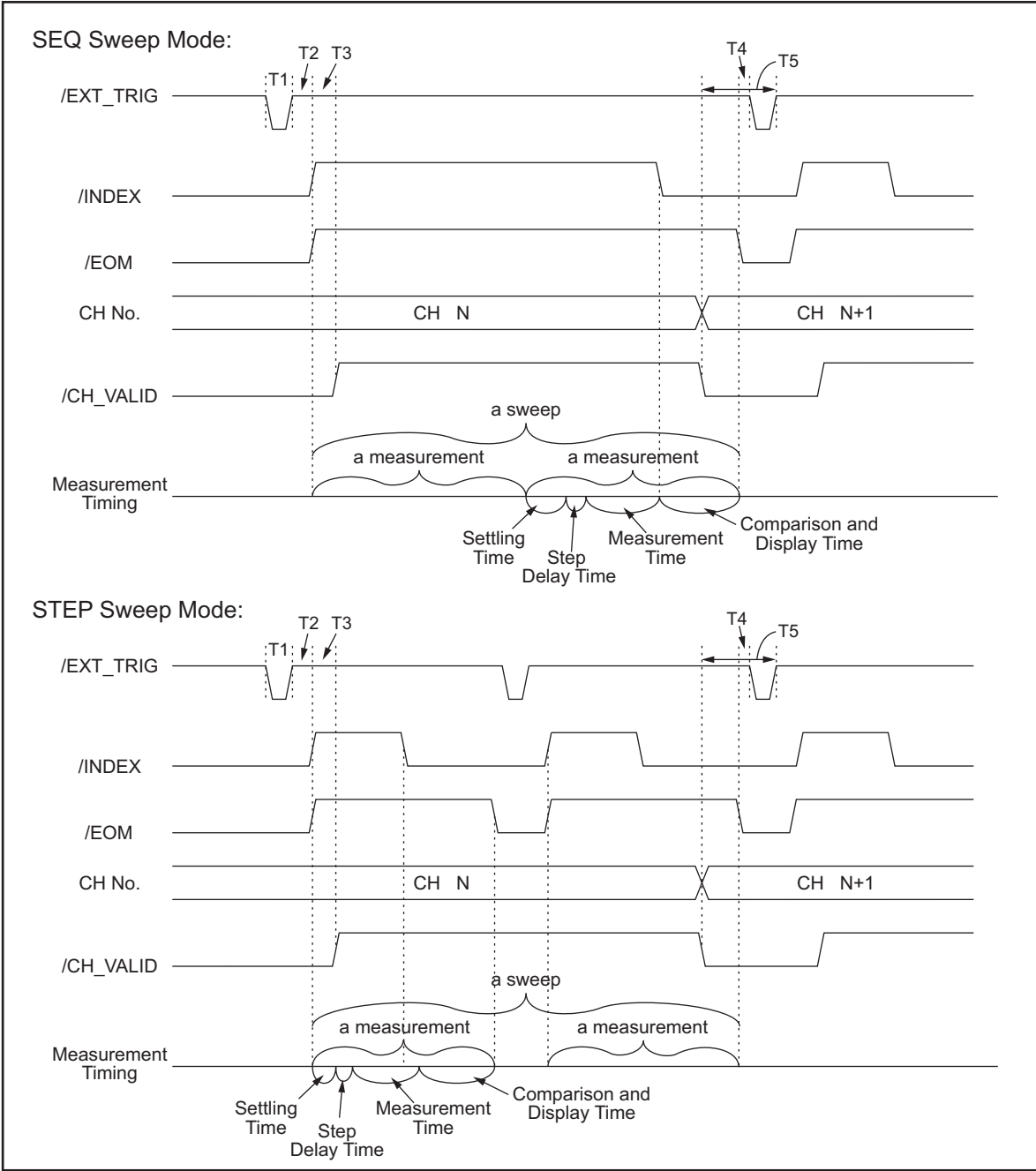

e4980aue1171

NOTE Settling time includes switching time for correction data. Comparison and display time is approx. 4.5 ms. Refer to Table E-8 for information on T1, T2, T3, T4, and T5.

Figure E-5 shows a sample of the system configuration using the input/output signals

F. Scanner Interface

Scanner Interface
Signal Input/Output Connector

described above.

Figure E-5 Sample of system configuration of scanner interface

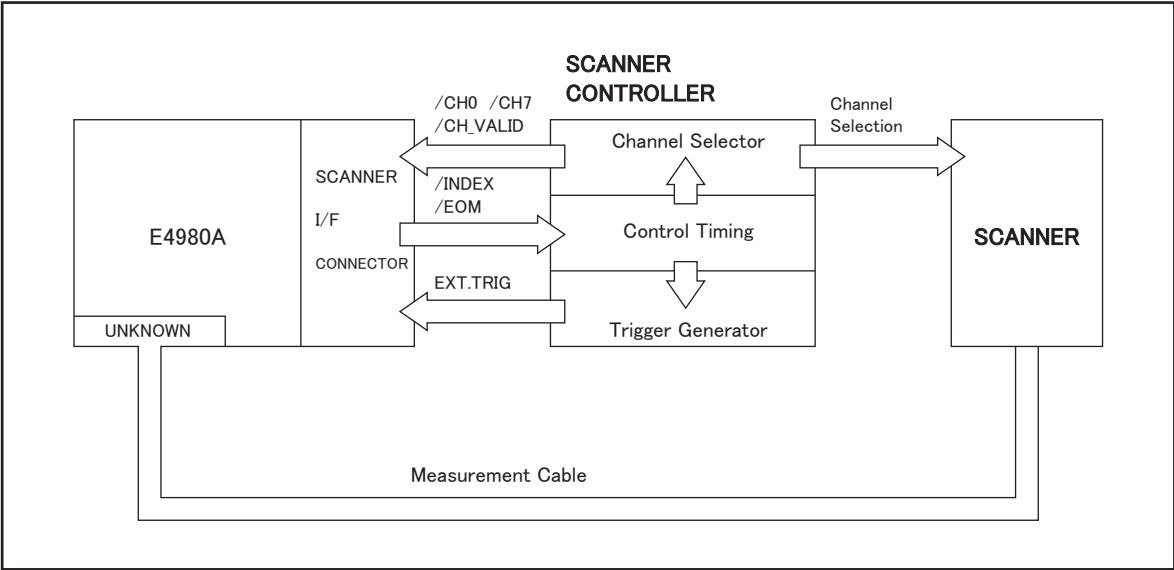

e4980aue1154

Electrical Characteristics of the Input/Output Signals

The electrical characteristics of the scanner interface I/O signals are described below.

Channel Selection Input Signals

The /CH0 to /CH7 and /CH_VALID signals are optocoupled to isolate DC inputs. Each signal is connected to the cathode of an LED in the optocoupler, which is current driven, requiring 5 mA to 20 mA for proper operation. The OFF-state voltage (high level) of each signal depends on the pull-up voltage (EXT. DCV) used. EXT. DCV can be set from 5 V to 15 V. The selector switches must be set according to the value of EXT. DCV used (Refer to Table E-9).

External Trigger Input Signals

The EXT_TRIG signal is optocoupled to dc isolate the input. This signal is connected to the cathode of an LED in an optocoupler which is current driven, requiring 6.3 mA to 15 mA for proper operation. The OFF state voltage (high level) of each signal depends on the pull-up voltage (EXT. DCV) used. EXT. DCV can be set from 5 V to 15 V. The bit selector switches must be set according to the value of EXT. DCV used (Refer to Table E-9).

Table E-9 DC isolate input signal electrical characteristics

Signal Name	Input Voltage		Input Voltage (when low) (reference value)		
			Pull-up Supply Voltage EXT. DCV		
	Low	High	5 V	12 V	15 V
/CH0 to /CH7 /CH_VALID	0 to 1 V	EXT.DCV	9.0 mA	12.7 mA	16.2 mA
EXT_TRIG	0 to 1 V	EXT.DCV	11.1 mA	10.5 mA	13.5 mA

Figure E-6 shows a diagram of channel selection input signals, and Figure E-7 shows a diagram of external trigger input signals.

Scanner Interface
Electrical Characteristics of the Input/Output Signals

Figure E-6 Diagram of channel selection input signal circuits

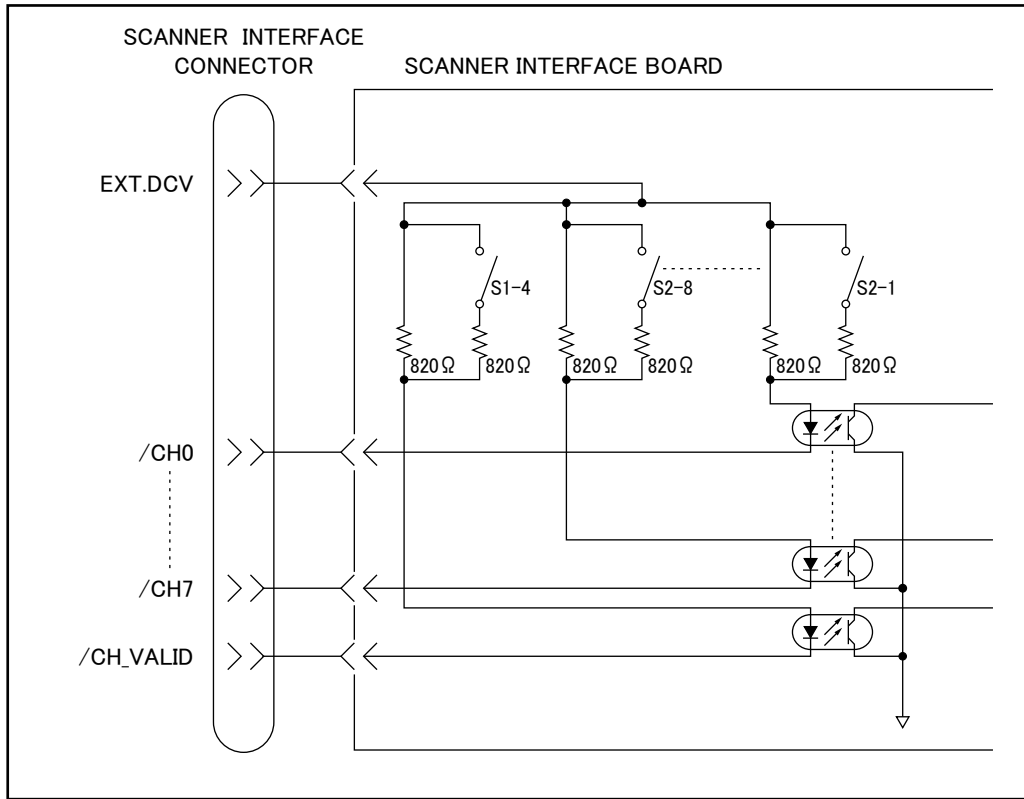

e4980aue1167

Control Output Signals

The /INDEX and /EOM signals have optocoupled open collector outputs. The combination of pull-up resistor and pull-up voltage must result in a current through the optocoupler of less than 6 mA (Refer to Table E-10).

Figure E-8 shows a schematic of the /INDEX and /EOM output circuits.

Table E-10 Output signal electrical characteristics

Signal Name	External Pull-up Voltage	Maximum Current
/INDEX /EOM	15 V max.	6 mA

Figure E-8

Simplified diagram of the output circuits

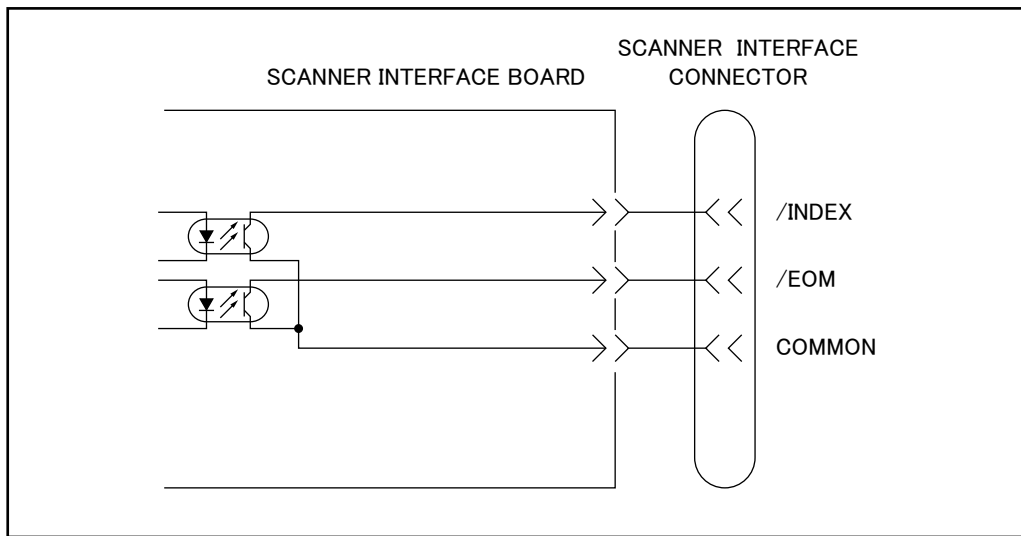

e4980aue1168

Setting Up the Scanner Interface Board

When you use the scanner interface I/O signals, you must set the pull-up resistor according to the external DC voltage (EXT. DCV) used with two switches on the scanner interface board.

The bit switch setting procedure for the pull-up resistor setting is described below.

Switch setting procedures

- Step 1.** Disconnect the power cable from the E4980A and allow enough time (a few minutes) for the internal capacitors to discharge.

CAUTION

Disconnecting the scanner interface board from the unit while power is supplied or immediately after turning off the power may damage the scanner interface board and the E4980A

- Step 2.** Remove the two screws that fix the scanner interface board to the E4980A's rear panel.
- Step 3.** Pull off the scanner interface board and disconnect the connected flat cable.
- Step 4.** Remove the scanner interface board.
- Step 5.** Set two bit switches (S1, S2) referring to Table E-11 and Table E-12.

Table E-11 Setting Bit Switch (S1)

Bit	Default	Pull-up Resistor	EXT. DCV	Function
1*1	On	316 Ω	5 V ≤ EXT.DCV ≤ 6 V	Switch for setting EXT_TRIG input resistance
2*1	Off	562 Ω	6 V < EXT.DCV ≤ 9 V	
3*1	Off	1 kΩ	9 V < EXT.DCV ≤ 15 V	
4	On	410 Ω (when on)	5 V ≤ EXT.DCV ≤ 8 V	Switch for setting /CH_VALID input resistance
		820 Ω (when off)	8 V < EXT.DCV ≤ 15 V	

*1.For bits 1 to 3 of bit switch S1, only one bit can be turned on at one time.

Scanner Interface
Setting Up the Scanner Interface Board

Table E-12 Setting Bit Switch (S2)

Bit	Default	Pull-up Resistor	EXT. DCV	Function
1-8	On	410 Ω (When on)	$5\text{ V} \leq \text{EXT.DCV} \leq 8\text{ V}$	/CH0 to /CH7 SW for input resistance
		820 Ω (When off)	$8\text{ V} < \text{EXT.DCV} \leq 15\text{ V}$	

NOTE Bit switches S1 and S2 can be identified by the labels “S1” and “S2” on the scanner interface board.

Step 6. Connect the flat cable to the scanner interface board, replace the scanner interface board, and fix it onto place with the two screws.

NOTE Applying excessive force to the screws may break the tapped hole (less than 0.98 N-m, 0.1 kgf-m).

How to Use the Scanner Interface Board

This section provides information necessary for the E4980A to operate using the scanner interface.

Basic Procedure

Figure E-9 shows a sample procedure for using the scanner interface. Follow this flow chart while referring to the following detailed descriptions.

Scanner Interface
 How to Use the Scanner Interface Board

Figure E-9 Basic Procedure

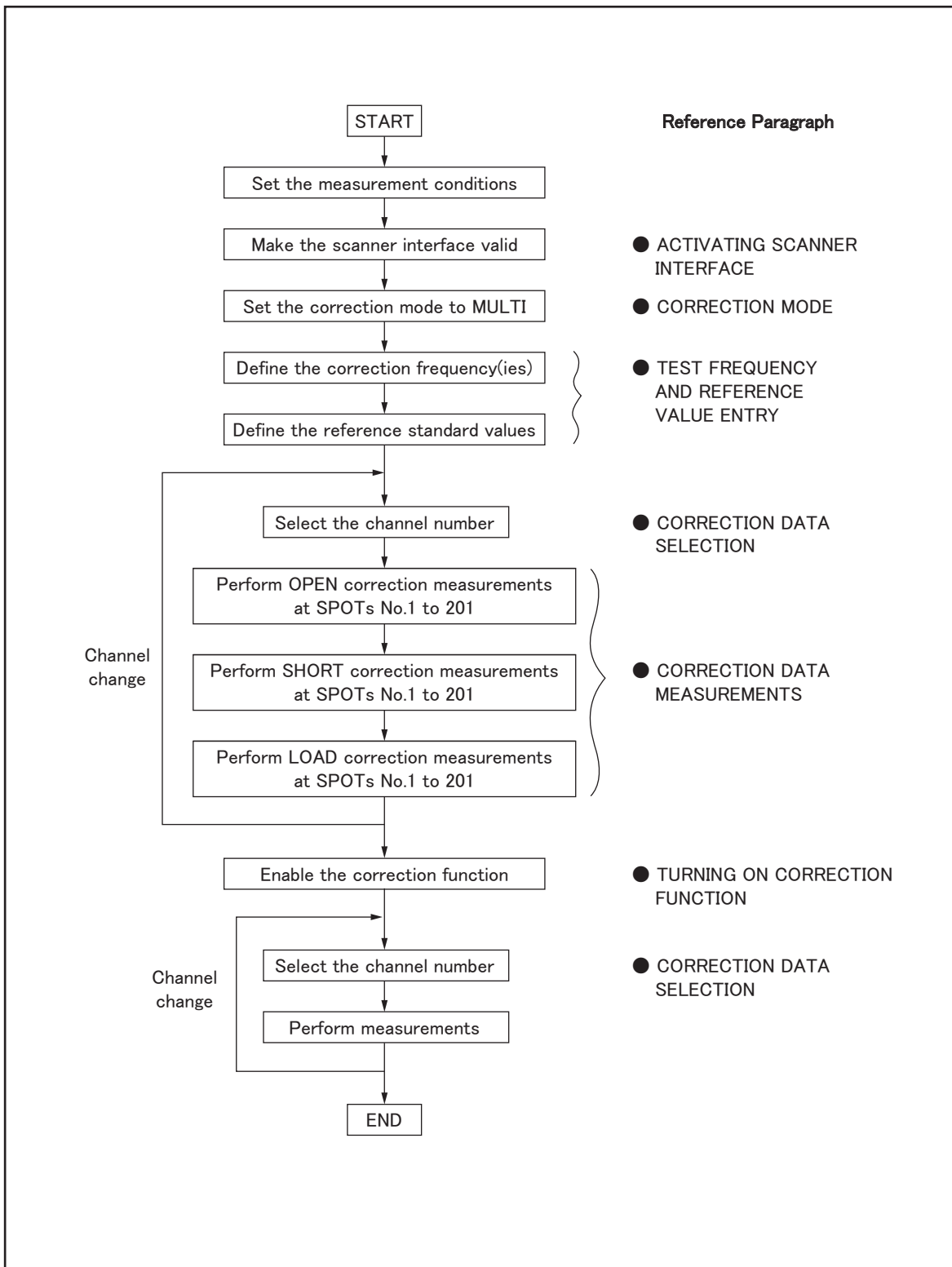

e4980aue1159

Activating Scanner Interface

Make the scanner interface valid to perform multi-channel correction and to input/output signals through the interface connector on the E4980A's rear panel.

NOTE Even when multi-channel correction is used without the interface connector (for example, controlling a scanner and the E4980A via GPIB), the following procedure must be performed.

- Step 1.** Press the **[System]** key to display the SYSTEM INFO page.
- Step 2.** Use the cursor arrow keys to move the cursor to the SCANNER I/F field. The following softkeys are displayed in the softkey label area.
 - ON
 - OFF
- Step 3.** Press the **ON** softkey. The scanner interface is now valid for output/input signals.

Correction Mode

Set the correction mode to **MULTI** to use the multi-channel correction function.

NOTE Before setting the correction mode to MULTI, you need to set the scanner interface to ON.

- Step 1.** Press the **[Meas Setup] - CORRECTION** to display the CORRECTION page.
- Step 2.** Use the cursor arrow keys on the front panel to move the cursor to the MODE field. The following softkeys are displayed in the softkey label area.
 - SINGLE
 - MULTI
- Step 3.** Press the **MULTI** softkey to use the multi-channel correction function.

Test Frequency and Reference Value Entry

It is possible to store the correction data for 201 test frequencies. These test frequencies are defined and monitored on the CORRECTION page.

On this page, the reference values (REF A and REF B) of the standards used for LOAD correction are defined at 201 test frequencies. The reference values can be stored with an appropriate function (FUNC). For example, to use the standard capacitor that has reference parallel capacitance and D values, the reference values should be stored with the Cp-D function. The reference values are also stored on the CORRECTION page.

NOTE The function of the standard on the CORRECTION page can be defined independently of the measurement function set on the MEAS SETUP page. For example, if the reference values are defined as the Cp-D function (entered with capacitance value and D value), the Z- θ parameter can be measured while performing the correction.

The setting procedure is given below.

Scanner Interface

How to Use the Scanner Interface Board

- Step 1.** Press the **[Meas Setup] - CORRECTION** to display the CORRECTION page.
- Step 2.** Use the cursor arrow keys on the front panel to move the cursor to the FUNC field.
- Step 3.** Use the softkeys to select the function to be used for entering the reference values.
- Step 4.** Use the cursor arrow keys on the front panel to move the cursor to the SPOT No. field.
- Step 5.** Use the numeric entry keys or softkeys on the front panel to enter a measurement point number for entering the reference value.
- Step 6.** Use the cursor arrow keys on the front panel to move the cursor to the FREQ field.
- Step 7.** When the FREQ field is OFF, press the **ON** softkey to use the correction data of the measurement point number.
- Step 8.** Use the numeric entry keys and softkeys on the front panel to enter a test frequency at a specific measurement point.
- Step 9.** Use the cursor arrow keys on the front panel to move the cursor to the REF A field.
- Step 10.** Use the numeric entry keys and softkeys on the front panel to enter the reference value of the primary parameter at the specified measurement point.
- Step 11.** Use the cursor arrow keys on the front panel to move the cursor to the REF B field.
- Step 12.** Use the numeric entry keys and softkeys on the front panel to enter the reference value of the secondary parameter at the specified measurement point.
- Step 13.** If necessary, move the cursor to the SPOT No. field and repeat steps 4 to 12 for other measurement points (frequency points).

NOTE

If a test frequency is not equal to any of the correction frequencies, correction (including OPEN, SHORT and LOAD) is not performed. In this case, the E4980A displays the raw measurement value including additional error due to the test fixture's residuals.

Correction Data Selection

Up to 128 sets of correction data for each scanner channel can be stored in the flash memory. Each set of correction data can be arbitrarily assigned a channel number for selection of correction data. You can set the channel number using the /CHO to /CH7 signals, and the /CH_VALID signals, or the :CORR:USE command via GPIB.

Channel Selection using Front Panel

Enter the channel number in the CH field on the CORRECTION page to set the channel number. Steps are shown below.

- Step 1.** Press the **[Meas Setup] - CORRECTION** to display the CORRECTION page.
- Step 2.** Use the cursor arrow keys to move the cursor to the CH field.
- Step 3.** Use the numeric entry keys or softkeys on the front panel to enter the channel number.

Channel Selection using Interface Connector

You can set the channel number with the channel selection signals (/CH0 to /CH7) and the channel valid signal (/CH_VALID). The /CH0 to /CH7 signals are 8-bit binary signals.

/CH0 is the LSB (least significant bit) and /CH7 is the MSB (most significant bit). An example is given below in Table F-13.

Table E-13 Example of Channel Selection

/CH0	/CH1	/CH2	/CH3	/CH4	/CH5	/CH6	/CH7	Channel Number
1	0	0	0	0	0	0	0	1
0	1	0	0	0	0	0	0	2
0	0	1	0	0	0	0	0	4
0	0	0	1	0	0	0	0	8
0	0	0	0	1	0	0	0	16
0	0	0	0	0	1	0	0	32
0	0	0	0	0	0	1	0	64
1	1	1	1	1	1	1	0	127

NOTE /CH0 to /CH7 are negative true, so 1 indicates LOW and 0 indicates HIGH in the above table.

/CH_VALID makes the E4980A acknowledge that the channel number is valid. The /CH_VALID signal must be set to LOW for the E4980A to set the channel number set with /CH0 to /CH7 signals.

NOTE In the case of channel number selection using the interface connector, when the E4980A is triggered, or when the E4980A starts a correction data measurement (for example, when the **MEAS OPEN** softkey is pressed), the E4980A acknowledges the channel number. Therefore, even if the /CH0 to /CH7 signals and the /CH_VALID signal are sent, the E4980A will not set the channel number until it is triggered or until it starts a correction data measurement.

Channel Selection using GPIB

The channel number used to select the correction data can be set using the :CORR:USE command. The syntax of this command is:

:CORRection:USE[:CHANnel] <channel number>

Where,

<channel number>: 0 to 127 (integer)

For example, the sample code to set the channel number to 20 is as follows.

```
rtn = viVPrintf(Agte4980a, ":CORR:METH MULT" + vbLf, 0)
rtn = viVPrintf(Agte4980a, ":CORR:USE 20" + vbLf, 0)
```

NOTE In case of the channel number selection using the :CORR:USE command, the E4980A acknowledges the channel number when it receives this command. Therefore, if the “:CORR:USE 10” command is sent via GPIB, the E4980A will set the channel number to

10 when it receives the command.

Monitoring Current Channel

You can monitor the current channel number selected for correction on the CORRECTION page and the MEAS DISPLAY page. The “CH” field on these pages indicates the current channel selected for correction.

Correction Data Measurements

For correction data measurements, it is necessary to perform OPEN, SHORT, and LOAD data measurements at 201 test frequencies for each channel.

The following is a sample procedure for performing correction data measurements for a channel. Repeat the following procedure for each scanner channel to be used.

- Step 1.** Select the scanner channel.
- Step 2.** Press the **[Meas Setup] - CORRECTION** key to display the CORRECTION page.
- Step 3.** Set the E4980A’s channel number equal to that selected in Step 1.
- Step 4.** [OPEN correction]
Open the measurement contacts of the selected scanner channel.
- Step 5.** Use the cursor arrow keys on the front panel to move the cursor to the SPOT No. field.
- Step 6.** Use the numeric entry keys or softkeys on the front panel to enter the measurement point number to perform an OPEN measurement.
- Step 7.** Use the cursor arrow keys on the front panel to move the cursor to the FREQ field.
- Step 8.** Press the **MEAS OPEN** softkey to measure OPEN condition at a specified test frequency.
- Step 9.** If necessary, repeat steps 5 to 8 for other measurement points (other frequencies).
- Step 10.** [SHORT correction]
Short the measurement contacts of the selected scanner channel.
- Step 11.** Use the cursor arrow keys on the front panel to move the cursor to the SPOT No. field.
- Step 12.** Use the numeric entry keys or softkeys to enter the measurement point number to perform a SHORT measurement.
- Step 13.** Use the cursor arrow keys on the front panel to move the cursor to the FREQ field.
- Step 14.** Press the **MEAS SHORT** softkey to measure SHORT condition at a specified test frequency.
- Step 15.** If necessary, repeat steps 11 to 14 for other measurement points (other frequencies).
- Step 16.** [LOAD correction]
Use the cursor arrow keys on the front panel to move the cursor to the SPOT No. field.
- Step 17.** Use the numeric entry keys or softkeys on the front panel to enter the measurement point number to perform a LOAD measurement.

- Step 18.** Connect the standard for test frequency correction of a specified measurement point number to the measurement contacts of the selected scanner channel.
- Step 19.** Use the cursor arrow keys on the front panel to move the cursor to the **FREQ** field.
- Step 20.** Press the **MEAS LOAD** softkey to measure the standard at a specified frequency.
- Step 21.** If necessary, repeat steps 16 to 20 for other measurement points (other frequencies).
- Step 22.** Change the scanner's and the E4980A's channel number and repeat steps 4 to 21 until this procedure has been performed for all scanner channels.

Activating the Correction Function

Set the correction function to ON in the following procedure in order to perform the correction using the correction data.

- Step 1.** Press the **[Meas Setup] - CORRECTION** to display the **CORRECTION** page.
- Step 2.** Use the cursor arrow keys on the front panel to move the cursor to the **SPOT No.** field.
- Step 3.** Use the numeric entry keys or the softkeys on the front panel to enter the measurement point number, and confirm that the correction frequencies to be used (test frequencies of the measurement point number entered) are set to **ON** (test frequency and reference values are displayed and **OFF** is not displayed).
- Step 4.** Use the cursor arrow keys on the front panel to move the cursor to the **OPEN** field.
- Step 5.** Press the **"ON"** softkey to set the **OPEN** correction function to **ON**.
- Step 6.** Use the cursor arrow keys on the front panel to move the cursor to the **SHORT** field.
- Step 7.** Press the **"ON"** softkey to set the **SHORT** correction function to **ON**.
- Step 8.** Use the cursor arrow keys on the front panel to move the cursor to the **LOAD** field.
- Step 9.** Press the **"ON"** softkey to set the **LOAD** correction function to **ON**.

Correction Data Confirmation

There are two ways to confirm the measurement data for each channel correction: Use the front panel, and read the data using a query via GPIB.

Confirm measurement data for correction on the front panel

Enter the channel number in the **CH** field on the **CORRECTION** page, and enter the measurement point number in the **SPOT No.** field to confirm that the measurement data for correction that have been already measured. Follow the steps below.

- Step 1.** Press the **[Meas Setup] - CORRECTION** to display the **CORRECTION** page.
- Step 2.** Use the cursor arrow keys on the front panel to move the cursor to the **CH** field.
- Step 3.** Use the numeric entry keys or the softkeys on the front panel to enter the channel number of the measurement data for correction that you want to confirm.
- Step 4.** Use the cursor arrow keys on the front panel to move the cursor to the **SPOT No.** field.
- Step 5.** Use the numeric entry keys or the softkeys on the front panel to enter the measurement

Scanner Interface

How to Use the Scanner Interface Board

point number of the measurement data for correction that you want to confirm (the number corresponding to the test frequency you want to confirm).

- Step 6.** Correction data of the primary (secondary) parameter for OPEN correction are displayed in the OPEN A (OPEN B) field. Correction data of the primary (secondary) parameter for SHORT correction in the SHORT A (SHORT B) field, and correction data of the primary (secondary) parameter for LOAD correction are shown in the LOAD A (LOAD B) field.

Confirm measurement data for correction using GPIB

To confirm the measurement data for each channel correction, use the following query to read the data via GPIB.

```
:CORRection:USE:DATA[:MULTi]? <channel number>
<channel number>                0 to 127 (integer)
```

The query response is as follows.

```
<open1 A>,<open1 B>,<short1 A>,<short1 B>,<load1 A>,<load1 B>,<open2 A>,<open2 B>,<short2 A>,<short2 B>,<load2 A>,<load2 B>,<open3 A>,<open3 B>,<short3 A>,<short3 B>,<load3 A>,<load3 B>,<br>:<br>:<br><open200 A>,<open200 B>,<short200 A>,<short200 B>,<load200 A>,<load200 B>,<br><open201 A>,<open201 B>,<short201 A>,<short201 B>,<load201 A>,<load201 B>,<br><NL^END>
```

Where,

<openXXX A>	Primary parameter measurement data of OPEN correction at a frequency of measurement point XXX.
<openXXX B>	Secondary parameter measurement data of OPEN correction at a frequency of measurement point XXX.
<shortXXX A>	Primary parameter measurement data of SHORT correction at a frequency of measurement point XXX.
<shortXXX B>	Secondary parameter measurement data of SHORT correction at a frequency of measurement point XXX.
<loadXXX A>	Primary parameter measurement data of LOAD correction at a frequency of measurement point XXX.
<loadXXX B>	Secondary parameter measurement data of LOAD correction at a frequency of measurement point XXX.
<NL^END>	Terminators (the EOI line is asserted while the New Line or Line Feed character is being sent on the bus).

NOTE

XXX in the above table indicates the measurement point number entered in the field.

F Handler Interface

This chapter provides information necessary to use Option 201 Handler Interface for the Agilent E4980A Precision LCR Meter.

Overview

The Agilent E4980A Option 201 Handler Interface outputs signals that indicate the end of a measurement cycle, the result of bin sorting by the comparator, and the result of Go/No-Go test by the list sweep comparator. In addition, the instrument accepts input of external trigger and key-lock signals. You can use these signals to easily integrate the E4980A with a component handler or system controller. This means that you can fully automate such tasks as component inspection, component sorting, and processing of quality management data for higher manufacturing efficiency.

Specifications

Output Signals

Active low, open collector, photo isolation

Table F-1 Output Signals

Signal	Overview
Result output	<ul style="list-style-type: none"> • Comparator Bin number, OUT OF BINS, status signal • List sweep comparator Results of sweep-by-sweep IN/OUT test and continuous comparison
/INDEX	“End of analog measurement” signal
/EOM	“End of all measurement” signal
/ALARM	Provides an alarm when an instantaneous power failure has been detected or the handler interface board has been reset.
/READY_FOR_TRIGGER	“Ready for trigger” signal

Input Signals

Photo isolation

Table F-2 Input Signals

Signal	Overview
/KEY_LOCK	Key lock (locks out the front panel keyboard)
/EXT_TRIG	External trigger signal, pulse width $\geq 1 \mu\text{s}$

Signal Line Definitions

The instrument uses three types of signals: test result output, control output, and control input. The definitions of test result output and control input signals differ depending on whether they are used for the comparator or the list sweep comparator.

This section explains the signal definitions that apply when using the handler interface with the comparator and with the list sweep comparator.

Signal Line Definitions for the Comparator

When the handler interface is used with the comparator, the following signal definitions apply:

- Test result output signals
/BIN1 to /BIN9, /AUX_BIN, /OUT_OF_BINS, /PHI (“primary parameter beyond upper limit” signal), /PLO (“primary parameter below lower limit” signal), /SREJ (“secondary parameter out of limits” signal), /OVLD (measurement failure” signal)
- Control output signals
/INDEX (“end of analog measurement” signal), /EOM (“end of measurement cycle” and “result data available” signal), /READY_FOR_TRIGGER (“ready for trigger” signal)
- Control input signals
/EXT_TRIG (“external trigger” signal), /KEY_LOCK (“key lock” signal)

Connector pin layouts and comparator signal descriptions are shown in Table F-13, Figure F-1, and Figure F-2. Also, Figure F-3 shows a signal timing chart.

NOTE A signal prefixed with a slash (/) indicates that the signal is negative logic (active low).

Table F-3 Pin layouts for the comparator

Pin number	Signal name	Signal direction	Description
1 2 3 4 5 6 7 8 9 10 11	/BIN1 /BIN2 /BIN3 /BIN4 /BIN5 /BIN6 /BIN7 /BIN8 /BIN9 /OUT_OF_BINS /AUX_BIN	Output	These signals indicate the result of sorting. They show into which bin the DUT has been sorted. All of these output signals are open-collector based.
12 13	/EXT_TRIG /EXT_TRIG	Input	An external trigger signal. These signals are used in the external trigger mode. Triggering occurs when the pulse reaches a rising edge.

Table F-3 Pin layouts for the comparator

Pin number	Signal name	Signal direction	Description
14 15	EXT.DCV2 EXT.DCV2	Input	External DC voltage. Supplies voltage for DC isolation input signals (/EXT_TRIG, /KEY_LOCK) and DC isolation output signals (/ALARM, /INDEX, /EOM). To use the internal DC voltage, switch the settings with the jumper on the handler interface board.
16 17 18	+5V +5V +5V	Output	Internal DC voltage.
19	/PHI	Output	“Primary parameter beyond upper limit” signal. This signal is output when the primary parameter has exceeded the upper limit for bins 1 to 9.
20	/PLO	Output	“Primary parameter below lower limit” signal. This signal is output when the primary parameter is below the lower limit for bins 1 to 9.
21	/SREJ	Output	“Secondary parameter out of limits” signal. This signal is output when the secondary parameter is out the limits.
22	/READY_FOR_TRIGGER	Output	“Ready for trigger” signal. This signal is output while the instrument is ready to accept trigger signals. This means that it is output while the measurement screen is in the “trigger wait” state. It is not output under any other conditions. Also, the signal is never output when the trigger source is set to Internal Trigger.
23	RESERVED	--	Not used.
24	/OVL	Output	“Measurement failed” signal. This signal is output when the analog measurement mechanism has failed to perform measurement (due to an overload). It is equivalent to the /UNBAL signal of the 4284A.
25	/KEY_LOCK	Input	“Key lock” signal. When this signal is input, the E4980A's front panel keys are all disabled.
26	RESERVED	--	Not used.
27 28	EXT.DCV1 EXT.DCV1	Input	External DC voltage. Supplies voltage for DC isolation signals (/BIN1 to /BIN9, /OUT_OF_BINS, /AUX_BIN, /PHI, /PLO, /SREJ, /OVL). To use the internal DC voltage, switch the settings with the jumper on the handler interface board.
29	/ALARM	Output	“Error detected” signal. This signal is output when an instantaneous power failure has been detected. It is also output when the handler interface board has been reset.
30	/INDEX	Output	“End of analog measurement” signal. This signal is output when analog measurement is complete. This means that once the handler has received this signal, the next DUT can be connected to the UNKNOWN terminal. However, measurement data are not available until the /EOM signal is output.
31	/EOM	Output	“End of measurement cycle” signal. When this signal is output, the measurement data and sorting results are available.
32 33	COM2 COM2	--	Common signals for external DC current EXT.DCV2.

Handler Interface
Signal Line Definitions

Table F-3 Pin layouts for the comparator

Pin number	Signal name	Signal direction	Description
34 35 36	COM1 COM1 COM1	--	Common signals for external DC current EXT.DCV1.

Figure F-1 Example of /PHI, /PLO, and /SREJ signal areas (for the comparator)

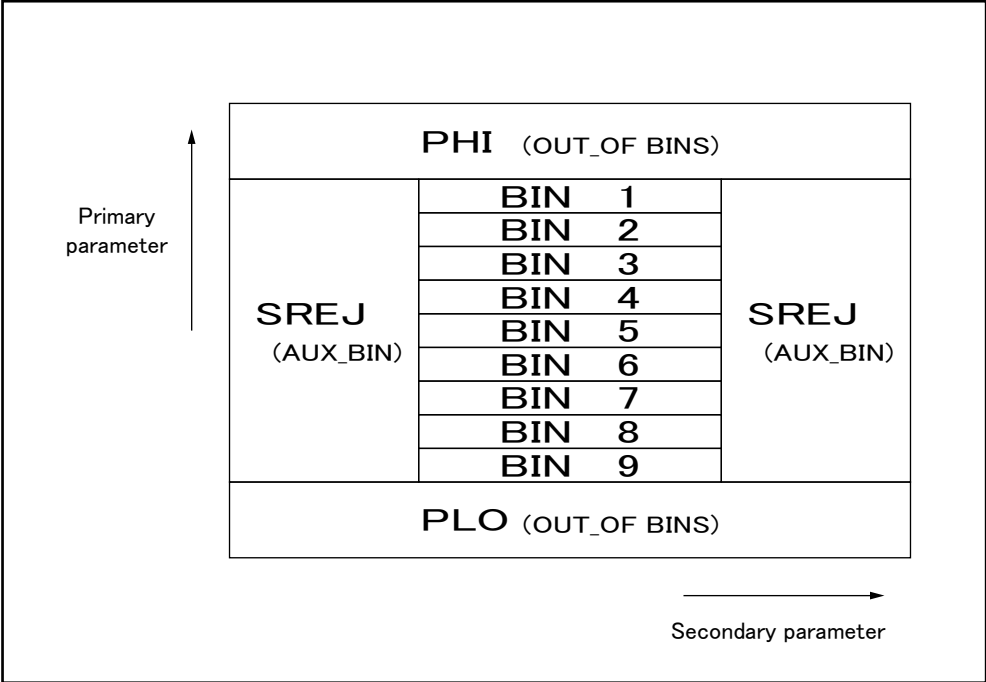

e4980aue1135

E. Handler Interface

Handler Interface
Signal Line Definitions

Figure F-2 Handler interface connector pin layout

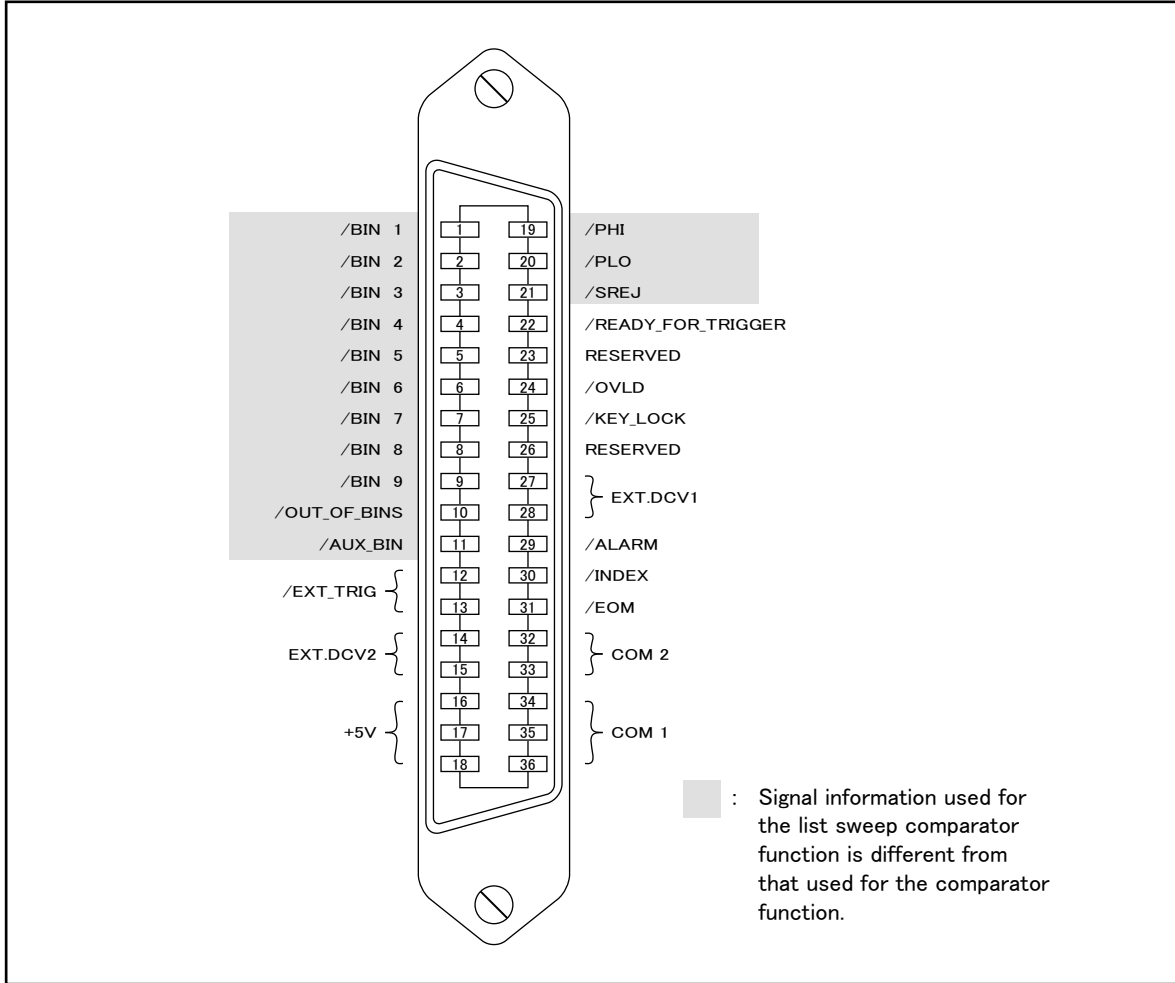

e4980aue1136

Figure F-3 Timing chart (for the comparator)

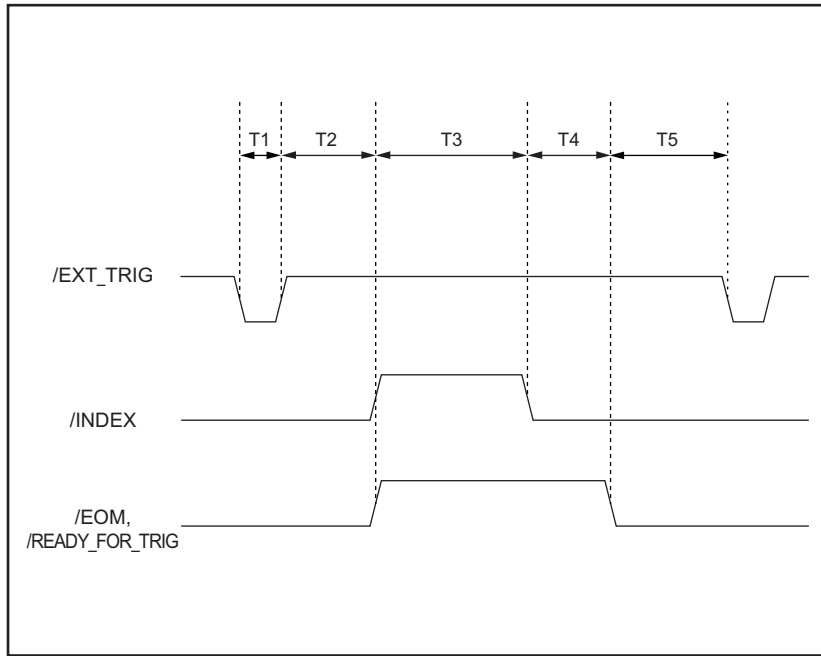

e4980auj1110

Table F-4 Time segments in the time chart

Time segment		Minimum value	Typical*1
T1	Trigger pulse width	1 μsec	-
T2	Measurement cycle	/INDEX and /EOM response time	350 msec
T3		Analog measurement time	Depends on settings
T4		Digital math time	0 Sec
T5	Trigger wait time after the output of /EOM, /READY_FOR_TRIGGER	0 Sec	-

*1. The measurement time is affected by the GPIB/USB/Network and Front panel processes.

Signal Line Definitions for the List Sweep Comparator

The signal definitions for the list sweep comparator differ from those for the comparator.

When the handler interface is used with the list sweep comparator, the following signal definitions apply:

- Test result output signals

Signals /BIN1 to /BIN9 and /AUX_BIN represent the results of IN/OUT tests at sweep points 1 to 10, respectively. /OUT_OF_BINS indicates whether the DUT has passed or failed the test (a DUT fails the test if it generates an OUT result in any of steps 1 to 201 during one cycle of sweep measurement).

These signals are output at the end of the sweep cycle.

- Control output signals

The output timings of /INDEX (“end of analog measurement”) and /EOM (“end of measurement cycle”) signals differ depending on the sweep mode for list sweep (these signals behave differently than when used for the comparator).

1. SEQ sweep mode

/INDEX is output when the last analog measurement in the sweep cycle is complete. /EOM is output when all the comparator test results become available after the end of the sweep cycle.

2. STEP sweep mode

/INDEX is output when the analog measurement step in each step of the sweep cycle is complete. /EOM is output when all the measurements in each step of the sweep cycle are complete (including the measurement time).

Connector pin layouts and comparator signal descriptions for the list sweep comparator are shown in Table F-13, Figure F-4, and Figure F-2. (the pin layouts for the list sweep comparator are the same as those for the comparator). Also, Figure F-5 shows a signal timing chart.

NOTE

A signal prefixed with a slash (/) indicates that the signal is negative logic (active low).

Table F-5 Pin layouts for the list sweep comparator

Pin number	Signal name	Signal direction	Description
1 2 3 4 5 6 7 8 9 10	/BIN1 /BIN2 /BIN3 /BIN4 /BIN5 /BIN6 /BIN7 /BIN8 /BIN9 /OUT_OF_BINS	Output	Failure at sweep point 1 (outside limits) Failure at sweep point 2 (outside limits) Failure at sweep point 3 (outside limits) Failure at sweep point 4 (outside limits) Failure at sweep point 5 (outside limits) Failure at sweep point 6 (outside limits) Failure at sweep point 7 (outside limits) Failure at sweep point 8 (outside limits) Failure at sweep point 9 (outside limits) This signal is output when the DUT fails at any of points 1 to 201 during one sweep cycle.
11	/AUX_BIN	Output	Failure at sweep point 10 (outside limits)
19-21	N.U.	--	Not used (always off at high level)
30	/INDEX	Output	SEQ sweep mode: This signal is output when the last analog measurement in the sweep cycle is complete. This means that once the handler has received this signal, the next DUT can be connected to the UNKNOWN terminal. However, measurement data are not available until the /EOM signal is output. STEP sweep mode: This signal is output when the analog measurement at each point in the sweep cycle is complete. This means that once the handler has received this signal, the instrument can proceed to the next sweep point. However, measurement data are not available until the /EOM signal is output.
31	/EOM	Output	“End of measurement cycle” signal SEQ sweep mode: This signal is output at the end of the sweep cycle. Therefore, when this signal is output, the measurement data and sorting results are available. STEP sweep mode: This signal is output when the measurement at each point is complete (including the comparator test time) and the corresponding measurement data are available. The comparator test result is available after the /EOM signal for the last sweep point is output.
12-18 22-29 32-36			Same assignments as for the comparator.

Figure F-4 Example of signal areas (for the list sweep comparator)

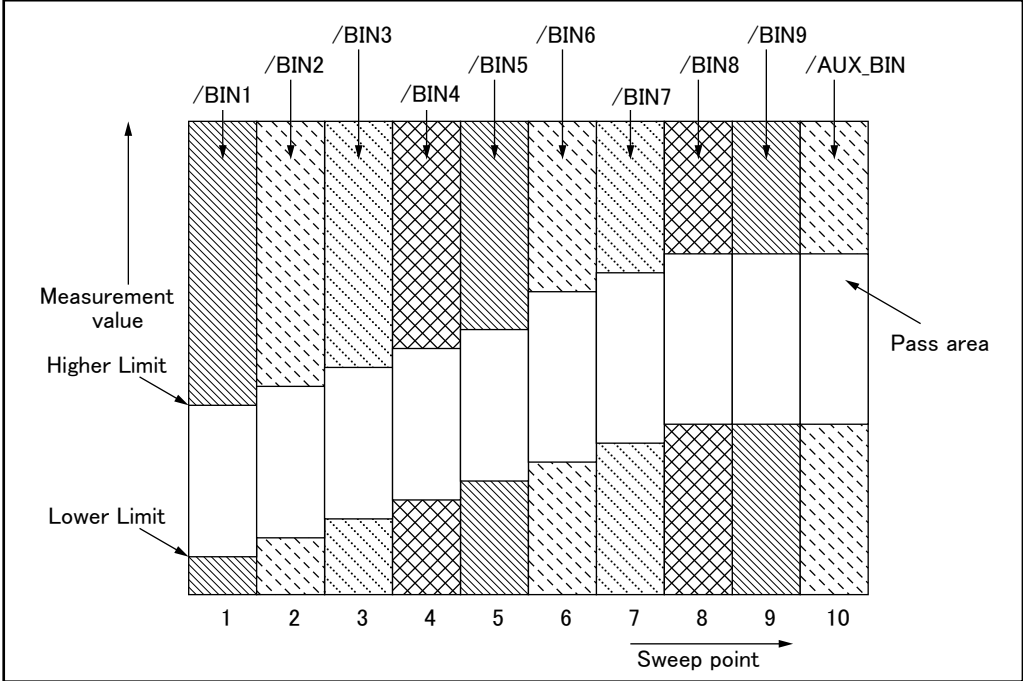

e4980aue1143

Figure F-5 Timing chart (for the list sweep comparator)

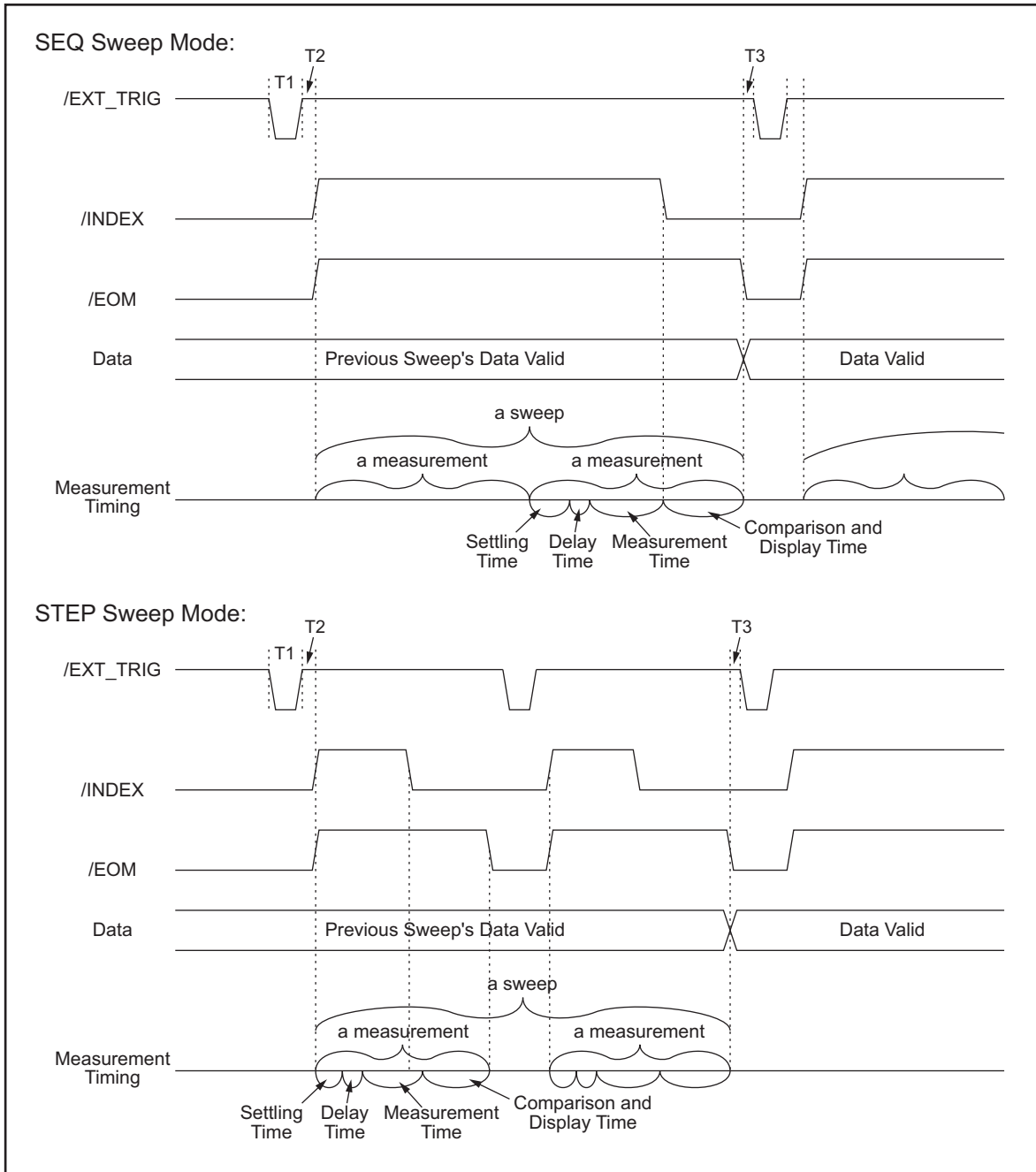

e4980aue1169

Table F-6 Time segments in the time chart

Time segment		Minimum value	Typical*1
T1	Trigger pulse width	1 μ sec	-
T2	/INDEX and /EOM response time of measurement time	0 Sec	350 msec

E. Handler Interface

Handler Interface
Signal Line Definitions

Table F-6 Time segments in the time chart

Time segment		Minimum value	Typical*1
T3	Trigger wait time after the output of /EOM	0 Sec	-

*1. The measurement time is affected by the GPIB/USB/Network and Front panel processes.

NOTE For settling and display times, refer to Chapter 11, “Specifications and Supplemental Information,” on page 399.

Electrical Characteristics

As described in the previous section, some signals have different meanings depending on whether they are used for the comparator or the list sweep comparator. However, all the signals always retain the same electric characteristics regardless of how they are used. The following descriptions apply both when the handler interface is used with the comparator and when it is used with the list sweep comparator.

DC Isolation Output Signals

DC isolation output signals (pins 1 to 11, 19 to 24, and 29 to 31) are output from an open collector photocoupler. This output signal is obtained as a voltage over a pull-up resistor that is mounted on the handler interface board. The output voltage is jumper-switchable between the internal power supply (+5 V, +12 V) and the external power supply (+5 to +24 V for EXT.DCV1 or +5 to +24 V for EXT.DCV2).

The DC isolation output signals use their dedicated electrical system independently of the control output signals. Therefore, the handler board has two separate circuit common lines: COM1 and COM2.

Table F-13 shows the electrical characteristics of the DC isolation output signals.

Table F-7 Electrical characteristics of the DC isolation output signals

Output Signals	Voltage output rating		Maximum current	Circuit common
	LOW	HIGH		
Test result output signals /BIN1 to /BIN9 /AUX_BIN /OUT_OF_BINS /PHI /PLO /SREJ /OVLD	0 to 0.5 V	DCV1*1	6 mA	When internal pull-up voltage is used: Circuit common of E4980A When external voltage (EXT.DCV1) is used: COM1
Control output signals /INDEX /EOM /ALARM /READY_FOR_TRIGGER	0 to 0.5 V	DCV2*2	6 mA	When internal pull-up voltage is used: Circuit common of E4980A When external voltage (EXT.DCV2) is used: COM1

- *1. +5 V or +12 V when internal power supply is used.
+5 V to +24 V (EXT.DCV1) when external power supply is used.
- *2. +5 V or +12 V when internal power supply is used.
+5 V to +24 V (EXT.DCV2) when external power supply is used.

Figure F-6 shows the output circuit configuration for the test result output signals, and Figure F-7 shows that for the control output signals.

Figure F-6

Output circuit configuration for the test result output signals

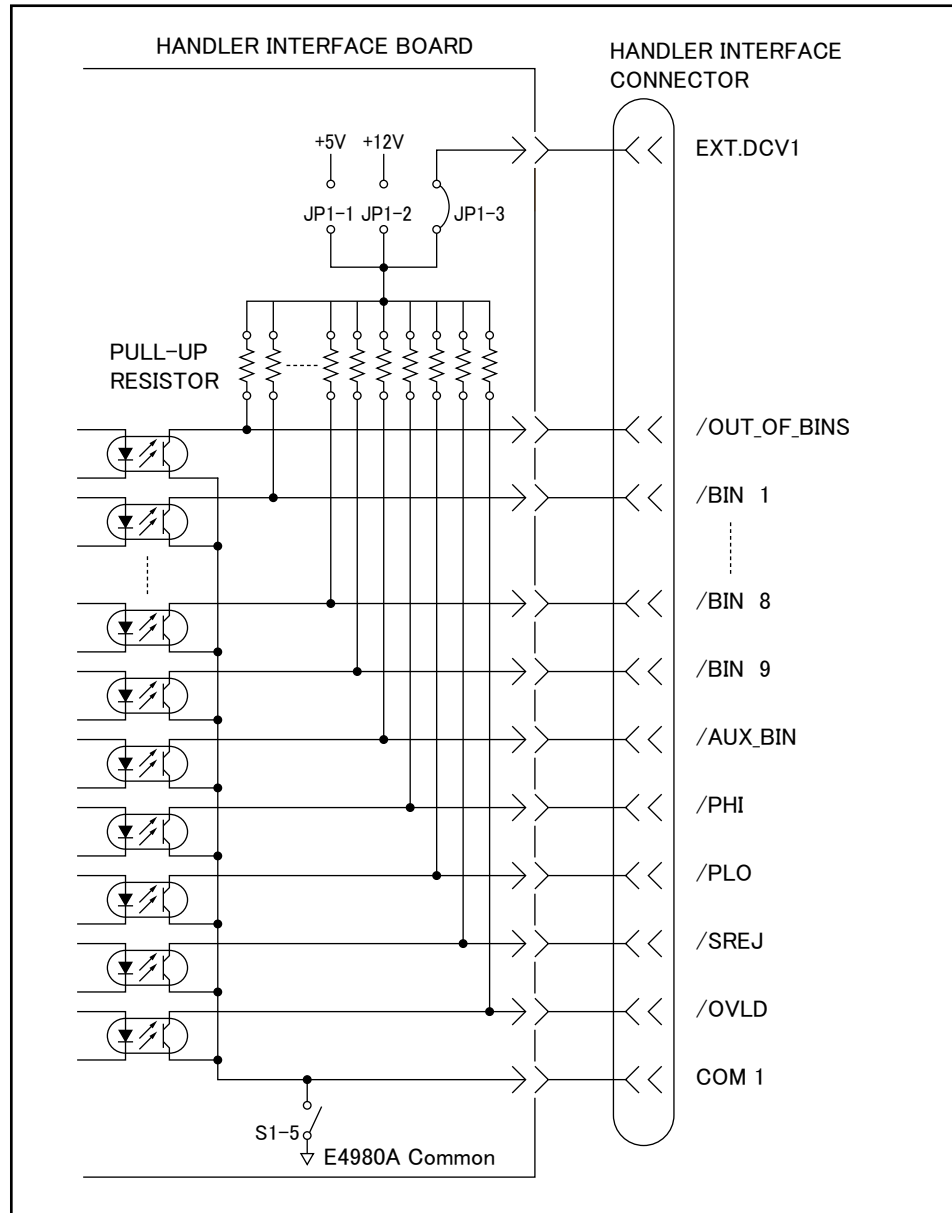

e4980aue1137

Figure F-7

Output circuit configuration for the control output signals

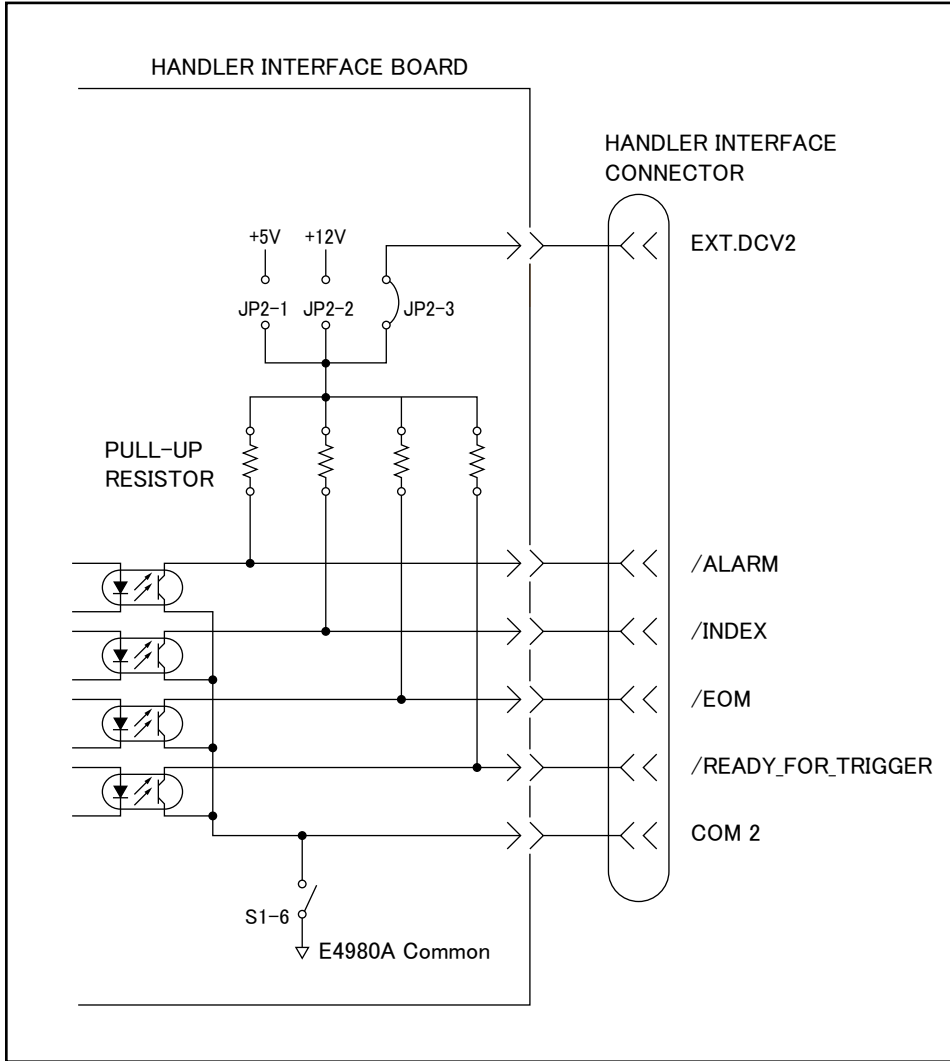

e4980aue1138

E. Handler Interface

DC isolation input signals (photo-coupled)

DC isolation input signals include /EXT_TRIG and /KEY_LOCK signals.

- 1. /EXT_TRIG signal

The /EXT_TRIG signal (pins 12 and 13) is input to the photocoupler LED (on the cathode side). When the signal rises from LOW to HIGH, the instrument is triggered. The photocoupler LED (on the anode side) is driven by either internal pull-up voltage (+5 V,+12 V) or external voltage (EXT.DCV2).

NOTE

The trigger input limiting resistor should be set via jumper J6 depending on the magnitude of the photocoupler anode voltage. For more information, see “Setting Up the Handler Interface Board” on page 530.

- 2. /KEY_LOCK signal

Handler Interface
Electrical Characteristics

The /KEY_LOCK signal (pin 25) is input to the photocoupler LED (on the cathode side). As long as this signal is Low, the instrument's front panel keys are all locked. The photocoupler LED (on the anode side) is driven by either internal supply voltage (+5 V,+12 V) or external supply voltage (EXT.DCV2). This voltage is applied to pin 15 or 16 of the instrument's connector.

The pull-up voltage, selected using jumper J4, determines the voltage of /KEY_LOCK (pin 25) in its OFF state as well as the /EXT_TRIG (pins 12 and 13) signal.

Table F-13 shows the electrical characteristics of the DC isolation input signals.

Table F-8 Electrical characteristics of the DC isolation input signals (typical)

Signal name	Input voltage		Input current (at Low)				Circuit common
			Pull-up voltage				
	LOW	HIGH	5 V	12 V	15 V	24 V	
/EXT_TRIG	≤ 1 V	5 V to 24 V	11.1 mA	10.5 mA	13.5 mA	10.6 mA	When internal pull-up voltage is used: Circuit common of E4980A When external voltage is used: COM2
/KEY_LOCK	≤ 1 V	5 V to 24 V	2.4 mA	6.6 mA	9.1 mA	14.6 mA	When internal pull-up voltage is used: Circuit common of E4980A When external voltage is used: COM2

Figure F-8 shows the circuit configuration for the input signals.

Figure F-8

Circuit configuration for the input signals

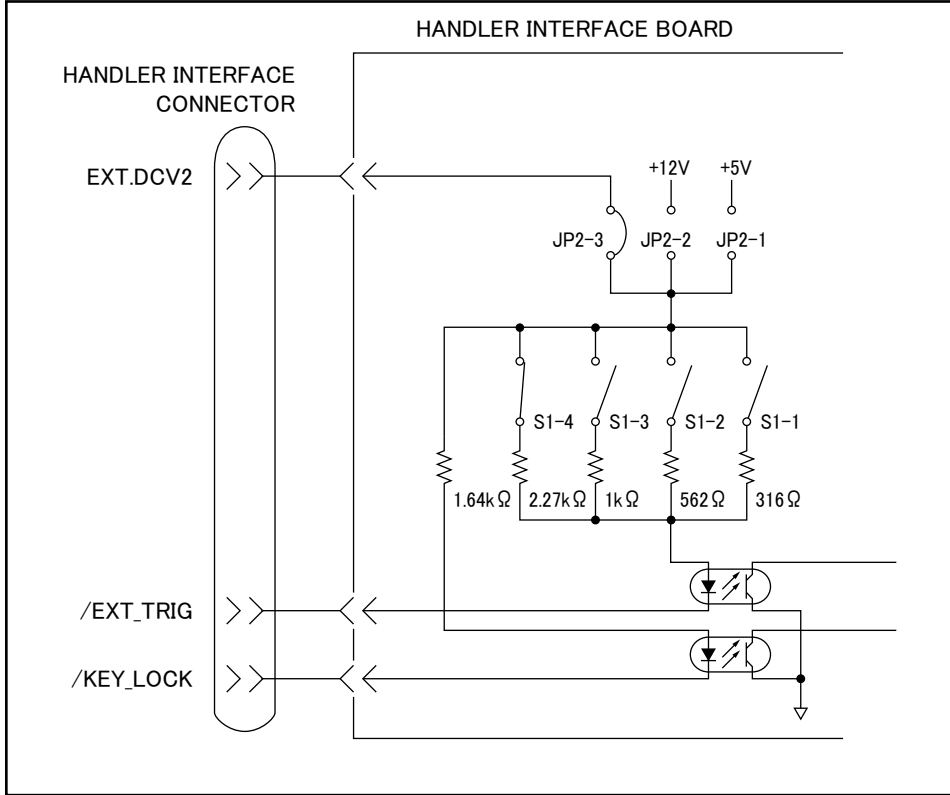

e4980aue1139

E. Handler Interface

Setting Up the Handler Interface Board

The handler interface board has two jumpers (JP1 and JP2) and one bit switch. They should be set depending on how the signals should be output from the handler interface connector (whether to make them open-collector based; whether to use the internal or external voltage output).

Table F-13 lists available jumper positions and their respective effects. It also shows available bitwise settings of the bit switch along with their respective results.

Table F-9 Internal jumper settings

Jumper number	Jumper position ^{*1}	Description	Affected signals
JP1	1	Sets the pull-up voltage for output signals to +5 V (internal).	/BIN1 to /BIN9 /AUX_BIN /OUT_OF_BIN /PHI to /OVLD
	2	Sets the pull-up voltage for output signals to +12 V (internal).	
	3(N)	Sets the pull-up voltage for output signals to external voltage (EXT.DCV1).	
	4	Not used.	
JP2	1	Sets the pull-up voltage for output signals and the drive voltage for input signals to +5 V (internal).	/INDEX /EOM /ALARM /EXT_TRIG /KEY_LOCK /READY_FOR_TRIGGER
	2	Sets the pull-up voltage for output signals and the drive voltage for input signals to +12 V (internal).	
	3(N)	Sets the pull-up voltage for output signals and the drive voltage for input signals to +5 V through +15V (EXT.DCV2).	
	4	Not used.	

*1. The factory default setting is position (N) shown in the table above.

NOTE

The handler interface board has labels “JP1” and “JP2” that indicate where jumpers JP1 and JP2 are located.

Both jumpers JP1 and JP2 have a circle mark indicating their #1 side.

Table F-10 Bit switch (S1) settings

Bit number *1	Factory default settings	Description	Affected signals
1	Off	When you set JP2 to 1 or JP2 to 3 and set EXT.DCV2 to 5 V through 6 V, set this bit to ON as well. As a result, the input current limiting resistor for the /EXT_TRIG signal is set to 316 Ω .	/EXT_TRIG
2	Off	When you set JP2 to 3 and set EXT.DCV2 to 6 V through 9 V, set this bit to ON as well. As a result, the input current limiting resistor for the /EXT_TRIG signal is set to 562 Ω .	
3	On	When you set JP2 to 2 or 3 and set EXT.DCV2 to 9 V through 15 V, set this bit to ON as well. As a result, the input current limiting resistor for the /EXT_TRIG signal is set to 1 k Ω .	
4	Off	When you set JP2 to 3 and set EXT.DCV2 to 15 V through 24 V, set this bit to ON as well. As a result, the input current limiting resistor for the /EXT_TRIG signal is set to 2.27 k Ω .	
5	Off	DC isolation switch for COM1. When this switch is ON, COM1 is connected to the instrument's circuit common line; therefore, the DC isolation output is not isolated. When this switch is OFF, the DC isolation output for COM1 is isolated.	/BIN1to /BIN9 /AUX_BIN /OUT_OF_BIN /PHI to /OVL D
6	Off	DC isolation switch for COM2. When this switch is ON, COM2 is connected to the instrument's circuit common line; therefore, the DC isolation output is not isolated. When this switch is OFF, the DC isolation output for COM2 is isolated.	/INDEX /EOM /ALARM /EXT_TRIG /KEY_LOCK /READY_FOR_TRIGGER
7	-	Not used.	-
8	-	Not used.	-

*1. The bit numbers referenced in this table are the numbers printed on the bit switch (S1) of the handler interface board.

NOTE

The handler interface board has a label “S1” that indicates where bit switch S1 is located. Only one of bits 1 through 4 can be ON at a time. You cannot turn ON any more than one bit at a time.

When you use the +5-V output of the handler interface connector (pins 16 to 18), set up the circuit common line by turning ON bit 5 or 6 of bit switch S1 and use COM1 or COM2

Handler Interface

Setting Up the Handler Interface Board

connected with the instrument's circuit common line as a +5-V common line.

Follow these steps to properly set up the jumpers and bit switch as well as the pull-up resistor.

Setting up the jumpers, bit switch, and pull-up resistor

- Step 1.** Turn off the power to the E4980A, unplug the power cable, and wait for a few minutes until the internal capacitors are completely discharged.

CAUTION

Do not disconnect the handler interface board from the instrument immediately after turning on or off the power to the E4980A. Doing so could damage the handler interface board and the E4980A itself.

- Step 2.** Remove the two screws that secure the handler interface board to the E4980A's rear panel.
- Step 3.** Draw out the handler interface board and unplug the flat cable that is connected to it.
- Step 4.** Remove the handler interface board.
- Step 5.** Go through the following flow chart to determine the jumper and bit switch settings for the test result output signals:

Figure F-9

Flow chart for determining the jumper and bit switch settings

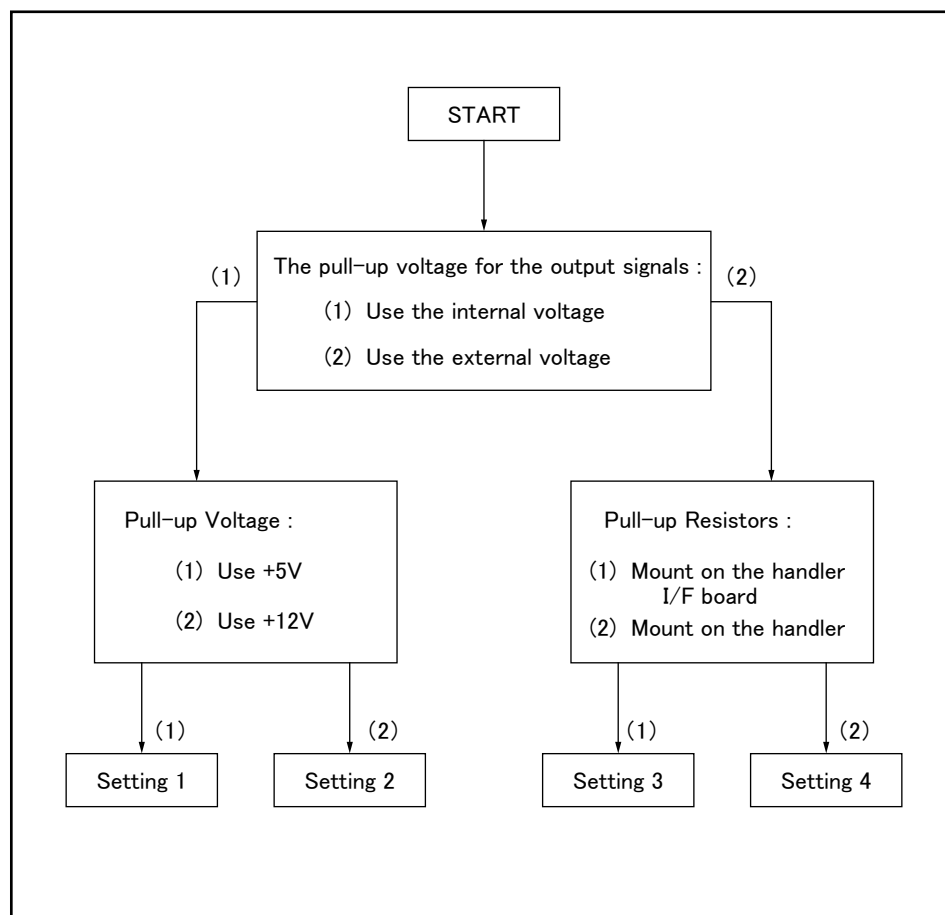

e4980aue1142

Step 6. Set up the jumpers as instructed in Table F-11.

Table F-11 Jumper and bit switch settings for test result output signals

Setting #	JP1	Bit 5 of S1	Circuit common	Pull-up resistor mounting	Pull-up voltage
Setting 1	1	On	Instrument's circuit common	Required	+5 V, internal
Setting 2	2	On	Instrument's circuit common	Required	+12 V, internal
Setting 3	3	Off	COM1	Required	+5 V through +24 V, external (EXT.DCV1)
Setting 4	-	Off	COM1	Not required	-

Step 7. If Table F-11 shows “Required” in the “Pull-up resistor mounting” column for the setting you want to use, mount the pull-up resistor for the comparator test result output signals. The pull-up resistor for DCV1 uses J1 and J2, whose locations are indicated as J1 and J2 on the handler interface board.

The pull-up resistor must be a resistor array of which the characteristics satisfy the following formula:

Equation F-1
$$R \cong \frac{V_p}{3}$$

where:

- V_p [V]: pull-up voltage
- R [k Ω]: pull-up resistance

For the typical pull-up resistor values, refer to Table F-14 on page 535.

Step 8. Go through the flow chart in Step 5 to determine the jumper and bit switch settings for the control output signals:

Step 9. Set up the jumpers as instructed in Table F-12.

Table F-12 Jumper and bit switch settings for control output signals

Setting #	JP2	Bit 6 of S1	Circuit common	Pull-up resistor mounting	Pull-up voltage
Setting 1	1	On	Instrument's circuit common	Required	+5 V, internal
Setting 2	2	On	Instrument's circuit common	Required	+12 V, internal
Setting 3	3	Off	COM2	Required	+5 V through +24 V, external (EXT.DCV2)

Handler Interface
Setting Up the Handler Interface Board

Table F-12 Jumper and bit switch settings for control output signals

Setting #	JP2	Bit 6 of S1	Circuit common	Pull-up resistor mounting	Pull-up voltage
Setting 4	-*1	Off	COM2	Not required	-

*1.Set to 3 when using input signals (it is not necessary to mount the pull-up resistor).

Step 10. If Table F-12 shows “Required” in the “Pull-up resistor mounting” column for the setting you want to use, mount the pull-up resistor for the control output signals. The pull-up resistor for DCV2 uses J3, whose location is indicated as J3 on the handler interface board.

The pull-up resistor must be a resistor array of which the characteristics satisfy the following formula:

Equation F-2
$$R \cong \frac{V_p}{3}$$

where:

- V_p [V]: pull-up voltage
- R [k Ω]: pull-up resistance

For the typical pull-up resistor values, refer to Table F-14 on page 535.

Step 11. Set up the bit switch for input signals as instructed in Table F-13.

Table F-13 Bit switch settings for input signals

Drive voltage	Bits 1 through 4 of S1*1	Circuit common
+5 V, internal	Turn ON bit 1.	Instrument’s circuit common
+12 V, internal	Turn ON bit 3.	Instrument’s circuit common
+5 V through +6 V, external (EXT.DCV2)	Turn ON bit 1.	COM2
+6 V through +9 V, external (EXT.DCV2)	Turn ON bit 2.	COM2
+9 V through +15 V, external (EXT.DCV2)	Turn ON bit 3.	COM2
+15 V through +24 V, external (EXT.DCV2)	Turn ON bit 4.	COM2

*1.Only one of bits 1 through 4 of the bit switch can be ON at a time.

Step 12. Connect the flat cable to the handler interface board. Reinstall the handler interface board to its original position and secure it with the two screws.

NOTE When tightening each screw, take care not to apply excessive force because doing so can break the tapped hole. (0.98 N-Em, 0.1 kgf-m Max).

The typical pull-up resistor values are:

Table F-14 The typical pull-up resistor values

Pull-Up Voltage	Pull-Up Resistor	Agilent Part Number
5 V	1.7 k Ω (= 5 V / 3 mA)	1810-0276 (1.5 k Ω)
9 V	3.0 k Ω (= 9 V / 3 mA)	1810-0278 (3.3 k Ω)
12 V	4.0 k Ω (= 12 V / 3 mA)	1810-0279 (4.7 k Ω)
15 V	5.0 k Ω (= 15 V / 3 mA)	1810-0279 (4.7 k Ω)
24 V	8.0 k Ω (= 24 V / 3 mA)	1810-0280 (10.0 k Ω)

Using the Handler Interface

Before you can use the handler interface, you need to set up the handler interface board. Then, set up the limit table for the comparator or the list sweep table for the list sweep comparator. Finally, enable the handler interface for signal input/output.

This section provides the handler interface setup procedures for the comparator and the list sweep comparator.

Setting Up the Handler Interface for Use with the Comparator

To set up the handler interface for the comparator, follow these steps:

- Step 1.** Press **[Meas Setup] - LIMIT TABLE** to open the LIMIT TABLE SETUP page.
- Step 2.** Set up the limit table for bin sorting. For more information, see the chapter on “Configuring Measurement Conditions.”
- Step 3.** Using the cursor movement keys on the front panel, move the cursor to the COMP field. The following softkeys appear on the softkey label area.
 - ON
 - OFF
- Step 4.** Press the ON softkey. The comparator is enabled.
- Step 5.** Press the **[System]** key to open the SYSTEM INFO page.
- Step 6.** Using the cursor movement keys on the front panel, move the cursor to the HANDLER I/F field. The following softkeys appear on the softkey label area.
 - ON
 - OFF
- Step 7.** Press the ON softkey. The handler interface is enabled for signal input/output.
- Step 8.** Press the **[Display Format]** key to open the MEAS DISPLAY page. Prepare for measurement by pressing one of the following softkeys: **MEAS DISPLAY**, **BIN No.**, and **BIN COUNT**.

NOTE

You can also use the BIN No. DISPLAY page to enable or disable the comparator.

Setting Up the Handler Interface Board for Use with the List Sweep Comparator

Follow these steps to set up the handler interface for the list sweep comparator:

- Step 1.** [**Meas Setup**] - **LIST SETUP** to open the LIST SWEEP SETUP page.
- Step 2.** Set up the list table (by defining the sweep points and upper/lower limits) so that you can conduct list sweep measurement. For more information, see the chapter on “Configuring Measurement Conditions.”
- Step 3.** Press the [**System**] key to open the SYSTEM INFO page.
- Step 4.** Using the cursor movement keys on the front panel, move the cursor to the HANDLER I/F field. The following softkeys appear on the softkey label area.
 - ON
 - OFF
- Step 5.** Press the ON softkey. The handler interface is enabled for signal input/output.
- Step 6.** Press the [**Display Format**] key to open the MEAS DISPLAY page. Press the **LIST SWEEP** softkey so that you can begin list sweep measurement.

Signals Activated when Overload Occurs

Signals activated when overload occurs are as follows. For conditions where overload occurs, refer to “Displaying Errors instead of Measurement Results” on page 76.

Table F-15 Signals activated when Overload Occurs

Measurement Parameter that overload occurred	Handler output (active signal)
Impedance measurement (except for Ls/Lp-Rdc)	/OUT_OF_BINS /OVLD
Impedance measurement (Ls/Lp-Rdc)	/OUT_OF_BINS /OVLD
DCR measurement (Ls/Lp-Rdc)	/OUT_OF_BINS /OVLD
Vdc measurement (primary)	/OUT_OF_BINS /OVLD
Idc measurement (primary)	/OUT_OF_BINS /OVLD
Vdc measurement (secondary)	normal
Idc measurement (secondary)	normal

NOTE

Signals are not output when the limit parameter (LMT field) is OFF during the list sweep measurement. Signals are not output when the comparator function (COMP field) is OFF during the measurement other than list sweep.

Functional Comparison between 4284A, 4279A, and E4980A

The Migration Guide has been provided for a functional comparison between 4284A, 4279A, and E4980A. Refer to the following website.

<http://www.agilent.com/find/e4980a/>

Numerics

4279A, 540
4284A, 540

A

ALC, 96
All Frequency Points, 115
ASCII Format, 259, 265
Attention of USB Memory, 177
Auto Recall, 185
Automatic Bias Polarity Control, 111
Automatic Level Control, 96
AUX BIN, 140
Auxiliary BIN, 140
Averaging, 101

B

Basic Specification, 401
Beep, 142, 161
Beep Mode, 142
Beep Tone, 162, 163
Bias Current Interface, 157, 480
Bias Current Source, 480
Bias Polarity, 111
BIN, 140
Binary Format, 259, 268
Buffer Memory, 257
BUS, 94
Bus Trigger, 94, 252

C

Cable Length, 132
Cable Length Correction, 211
Calibration
 Recommended Period, 452
Capacitance, 199
Characteristics Example, 216
Checking the Shipment, 23
Circuit Mode, 198
Cleaning, 451
Command Reference, 282
Comment, 93
Comment Line, 46
Comparator, 136
Configuration Save, 176
Correction, 115, 211
 All Frequency Points, 118
 Specified Frequency Points, 123
Correction Mode, 131
Cp, 198
Cs, 198

D

Data Buffer Memory, 257
Data Format, 265

Data Processing Flowchart, 365
Data Save, 176
DC Bias, 41
DC Bias Current Isolation, 100
DC Bias Current Monitor, 107
DC Bias Voltage Monitor, 106
DC Source, 41, 110
 Terminal, 42
DCI ISO, 100
DCI Measurement, 109
DCR Measurement, 108
Deviation, 113
Deviation Measurement, 113
Device Selector, 228
DHCP, 168

E

EMC, 435
Environment, 435
Equivalent key, 283
Error Message, 462
EXT, 94
External Trigger, 94, 252

F

Firmware Version, 159, 458
Fixture, 194
Four Terminal Measurement Method, 206
Four Terminal Pair, 203
Front Panel, 39
Fuse, 26

G

General Specification, 430
GPIB, 226, 227, 420
GPIB Address, 167, 228
Guard Plate, 209

H

Handler Interface, 158, 512

I

IEEE Command, 248
Impedance, 195
Inductance, 199
Infinity, 76
Initializing, 90
INT, 94
Internal Memory, 176
Internal Trigger, 94, 252
Interpolation Method, 118
IP Address, 168
Items Packaged, 24

K

Key Lock, 448

L

LAN, 44, 168, 226, 229, 420

LCD Display, 46

Limit Mode, 136

List of Default Values, 473

List Sweep, 146

Mode, 85, 147

Sweep Parameter, 148

with two parameters, 321

Local Lockout, 250

Lp, 198

Ls, 198

M

MAC Address, 159

MAN, 94

Manual Change, 458

Manual Printing History, 2

Manual Trigger, 94, 252

Measurement Example

Capacitor, 218

Inductor, 221

Using DC Source, 223

Measurement Procedure, 194

Medium, 179

Medium Mode, 179

Monitor Information, 159

Multi Correction Mode, 131

N

Nominal, 400

Nominal Value, 138

Notational Convention, 282

O

OPEN Correction, 118, 211

OPEN/SHORT Correction, 211

OPEN/SHORT/LOAD Correction, 211

Operating Environments, 31

Option, 159, 285, 421

Option 001, 421

Option 002, 44, 157, 429, 480

Option 005, 429

Option 007, 429

Option 201, 43, 158, 429, 512

Option 301, 43, 159, 429, 488

Option 710, 429

Output Format, 259

Overload, 76, 454, 538

P

Page

CATALOG, 178

CORRECTION, 115

LIMIT TABLE SETUP, 133

LIST SWEEP SETUP, 146

MEAS SETUP, 91

SELF TEST, 171

SERVICE, 173

SYSTEM CONFIG, 160

SYSTEM INFO, 156

Parallel Circuit Mode, 198

Parameters, 283

Parasitics Impedance, 215

Parasitics Incident, 215

Power Cable, 27

Power Supply, 26

Power Switch

Turning the Power ON and OFF, 34

Preset, 41

Product Overview, 38

R

Rear Panel, 43

Recall, 176

Auto Recall, 185

Recommended Calibration Period, 452

Register Number, 180

Regular Calibration, 452

Remote Control System, 226

GPIB, 227

LAN, 229

Remote Mode, 250

Replacement, 452

Requesting Repair, 452

Residual Impedance, 121

Resolution

DC Bias, 69

Frequency, 64

Test Signal Level, 66

Rp, 198

Rs, 198

S

Safety, 435

Sample Program, 367

Save, 176

Measurement Result, 186

Screenshot, 191

System Information, 174

Save/Recall, 176

Instrument Configuration State, 178

Scanner Interface, 159, 488

SCPI Command, 248

*CLS, 284

*ESE, 284

*ESR?, 284

*IDN?, 284

*LRN?, 285

*OPC, 285
 *OPC?, 285
 *OPT?, 285
 *RST, 285
 *SRE, 286
 *STB?, 286
 *TRG, 286
 *TST?, 286
 *WAI, 286
 :ABORT, 287
 :AMPLitude:ALC, 287
 :APERture, 287
 :BIAS:CURRent[:LEVel], 288
 :BIAS:POLarity:AUTO, 288
 :BIAS:POLarity:CURRent[:LEVel], 289
 :BIAS:POLarity:VOLTagE[:LEVel], 289
 :BIAS:RANGe:AUTO, 289
 :BIAS:STATe, 290
 :BIAS:VOLTagE[:LEVel], 290
 :COMParator:ABIN, 291
 :COMParator:BEEPer, 291
 :COMParator:BIN:CLEar, 291
 :COMParator:BIN:COUNt:CLEar, 292
 :COMParator:BIN:COUNt:DATA, 292
 :COMParator:BIN:COUNt[:STATe], 292
 :COMParator:MODE, 292
 :COMParator:SEQuence:BIN, 293
 :COMParator:SLIMit, 294
 :COMParator:SWAP, 294
 :COMParator:TOLerance:BIN[1-9], 295
 :COMParator:TOLerance:NOMinal, 295
 :COMParator[:STATe], 294
 :CONTRol:CBias:STATe, 295
 :CONTRol:HANDler:STATe, 296
 :CONTRol:SCANner:STATe, 296
 :CORRection:LENGth, 297
 :CORRection:LOAD:STATe, 297
 :CORRection:LOAD:TYPE, 297
 :CORRection:METHod, 298
 :CORRection:OPEN:STATe, 299
 :CORRection:OPEN[:EXECute], 299
 :CORRection:SHORT:STATe, 299
 :CORRection:SHORT[:EXECute], 299
 :CORRection:SPOT[1-201]:FREQuency[:SELeCted], 300
 :CORRection:SPOT[1-201]:LOAD:MULTiple:STANdard, 300
 :CORRection:SPOT[1-201]:LOAD:MULTiple[:EXECute], 300
 :CORRection:SPOT[1-201]:OPEN:MULTiple[:EXECute], 301
 :CORRection:SPOT[1-201]:SHORT:MULTiple[:EXECute], 301
 :CORRection:SPOT[1-201]:STATe, 301
 :CORRection:USE:DATA:SINGle, 303
 :CORRection:USE:DATA[:MULTi], 302
 :CORRection:USE[:CHANnel], 302
 :CURRent[:LEVel], 303
 :DISPlay:CCLEar, 304
 :DISPlay:ENABle, 304
 :DISPlay:LINE, 304
 :DISPlay:PAGE, 305
 :DISPlay[:WINDow]:TEXT[1-2][:DATA]:FMSD:DATA, 306
 :DISPlay[:WINDow]:TEXT[1-2][:DATA]:FMSD[:STATe], 306
 :FETCh:SMONitor:IAC, 307
 :FETCh:SMONitor:IDC, 307
 :FETCh:SMONitor:VAC, 307
 :FETCh:SMONitor:VDC, 308
 :FETCh[:IMPedance]:CORReCted, 307
 :FETCh[:IMPedance][:FORMatted], 307
 :FORMat:ASCii:LONG, 308
 :FORMat:BORDER, 308
 :FORMat[:DATA], 309
 :FREQuency[:CW], 309
 :FUNCTion:DCResistance:RANGe:AUTO, 309
 :FUNCTion:DCResistance:RANGe[:VALue], 310
 :FUNCTion:DEV[1-2]:MODE, 310
 :FUNCTion:DEV[1-2]:REFerence:FILL, 311
 :FUNCTion:DEV[1-2]:REFerence[:VALue], 311
 :FUNCTion:IMPedance:RANGe:AUTO, 311
 :FUNCTion:IMPedance:RANGe[:VALue], 312
 :FUNCTion:IMPedance[:TYPE], 312
 :FUNCTion:SMONitor:IAC[:STATe], 313
 :FUNCTion:SMONitor:IDC[:STATe], 314
 :FUNCTion:SMONitor:VAC[:STATe], 314
 :FUNCTion:SMONitor:VDC[:STATe], 315
 :HCOpy:SDUMp:DATA, 315
 :INITiate:CONTInuous, 316
 :INITiate[:IMMediate], 316
 :LIST:BAND[1-201], 316
 :LIST:BIAS:CURRent, 317
 :LIST:BIAS:VOLTagE, 317
 :LIST:CLEar:ALL, 318
 :LIST:CURRent, 318
 :LIST:DcSource:VOLTagE, 318
 :LIST:FREQuency, 319
 :LIST:MODE, 319
 :LIST:SEQuence:TSTamp:CLEar, 320
 :LIST:SEQuence:TSTamp:DATA, 320
 :LIST:STIMulus:DATA, 320
 :LIST:STIMulus:MDATa, 321
 :LIST:STIMulus:TYPE, 321
 :LIST:VOLTagE, 322
 :MEMory:CLEar, 322
 :MEMory:DIM, 323
 :MEMory:FILL, 323
 :MEMory:READ, 323
 :MMEMory:DELeTe[:REGister], 323
 :MMEMory:LOAD:STATe[:REGister], 324
 :MMEMory:STORe:STATe[:REGister], 324
 :OUTPut:DC:ISOLation:LEVel:AUTO, 324
 :OUTPut:DC:ISOLation:LEVel:VALue, 325
 :OUTPut:DC:ISOLation[:STATe], 325

- :OUTPut:HPOWer, 326
 - :SOURce:DCSource:STATe, 326
 - :SOURce:DCSource:VOLTage[:LEVel], 326
 - :STATus:OPERation:CONDition, 327
 - :STATus:OPERation:ENABLE, 327
 - :STATus:OPERation[:EVENT], 327
 - :SYSTem:BEEPer:STATe, 328
 - :SYSTem:BEEPer:TONE, 328
 - :SYSTem:BEEPer[:IMMEDIATE], 327
 - :SYSTem:COMMunicate:GPIB[:SELF]:ADDRess, 329
 - :SYSTem:COMMunicate:LAN[:SELF]:ADDRess, 329
 - :SYSTem:COMMunicate:LAN[:SELF]:AIP[:STATe], 329
 - :SYSTem:COMMunicate:LAN[:SELF]:CONFigure, 330
 - :SYSTem:COMMunicate:LAN[:SELF]:CONTRol, 330
 - :SYSTem:COMMunicate:LAN[:SELF]:CURRent:ADDRess, 330
 - :SYSTem:COMMunicate:LAN[:SELF]:CURRent:DGATeway, 331
 - :SYSTem:COMMunicate:LAN[:SELF]:CURRent:SMASK, 331
 - :SYSTem:COMMunicate:LAN[:SELF]:DGATeway, 331
 - :SYSTem:COMMunicate:LAN[:SELF]:DHCP[:STATe], 331
 - :SYSTem:COMMunicate:LAN[:SELF]:MAC, 332
 - :SYSTem:COMMunicate:LAN[:SELF]:PRESet, 332
 - :SYSTem:COMMunicate:LAN[:SELF]:REStart, 332
 - :SYSTem:COMMunicate:LAN[:SELF]:SMASK, 332
 - :SYSTem:DATE, 333
 - :SYSTem:ERRor[:NEXT], 333
 - :SYSTem:KLOCK, 334
 - :SYSTem:PRESet, 334
 - :SYSTem:REStart, 334
 - :SYSTem:TIME, 334
 - :SYSTem:TZONE, 335
 - :TRIGger:DELay, 336
 - :TRIGger:SOURce, 336
 - :TRIGger:TDEL, 337
 - :TRIGger[:IMMEDIATE], 336
 - :VOLTage[:LEVel], 337
 - Screenshot
 - Save to controller, 315
 - Save to USB memory, 191
 - Self Test, 171, 449
 - Sequential Mode, 85, 136, 147
 - Serial Number, 159, 458
 - Plate, 44, 458
 - Series Circuit Mode, 198
 - Service Mode, 454
 - Service Request, 263
 - Shield, 210
 - SHORT Correction, 121, 211
 - SICL-LAN, 230
 - Single Correction Mode, 131
 - Skip Key, 50
 - Specification, 400
 - Bias Current Interface, 481
 - Handler Interface, 513
 - Scanner Interface, 489
 - Specified Frequency Points, 115
 - SRQ, 263
 - Status Byte, 271
 - Status Register, 263
 - Step Delay Time, 104
 - Step Mode, 85, 147
 - Stray Admittance, 118
 - Supplemental Information, 436
 - Swap Parameter, 134
 - Sweep Mode, 85, 147
 - Syntax, 282
 - System Date, 165
 - System Information, 156
- ## T
- Telnet, 235
 - Test Fixture, 211, 482
 - Test Lead, 132, 482
 - Test Signal Level, 201
 - Time Zone, 164
 - Tolerance Mode, 136
 - Trigger, 94
 - External, 44
 - Trigger Delay Time, 102
 - Trigger Mode, 94
 - Trigger Source, 252
 - Trigger System, 251
 - Trouble Occurs, 454
 - Two Terminal Measurement Method, 206
 - Typeface Conventions, 6
 - Typical, 400
- ## U
- USB, 226, 241, 420
 - USB Address, 159
 - USB Memory, 176
 - USB Port, 242
 - USB Remote Control System, 241
 - Users Guide, 6
- ## V
- Varactor Diode, 111
- ## W
- Warning Message, 470
 - Warranty Period, 5
 - Web Server, 238